

20948 Cryogenic Secondary Standard

Specifications

Features

- Low uncertainty: $\pm 0.010^{\circ}\text{C}$ at TPW
- Calibration: NIST traceable, NVLAP Accredited (Lab Code 200706-0) calibration report
- Compatibility: 100 ohm resistance at 0°C make the 20948 compatible with most readout devices
- Stability: Proprietary seal locks out moisture and contaminants to insure stability
- Durability: Not for use in vibration service, more durable than an SPRT

Specifications

- Nominal resistance: 100 ohms at 0°C
- Temperature coefficient of resistance: 0.003925 ohms/ohm/ $^{\circ}\text{C}$ nominal
- Temperature range: -196°C to 200°C
- Insulation resistance: 500 megohms minimum at 20°C
- Sheath material: 316L stainless steel
- Lead wire: Teflon™ insulated, nickel-plated stranded copper, 22 AWG
- Short term repeatability and hysteresis: $\pm 0.013^{\circ}\text{C}$ (0.0051 ohms) maximum change at TPW over any 5 consecutive thermal cycles from -196°C to 200°C
- Minimum immersion: 6.0 inches
- Includes calibration from -196°C to 200°C

20948 Cryogenic Secondary Standard

Ordering Information

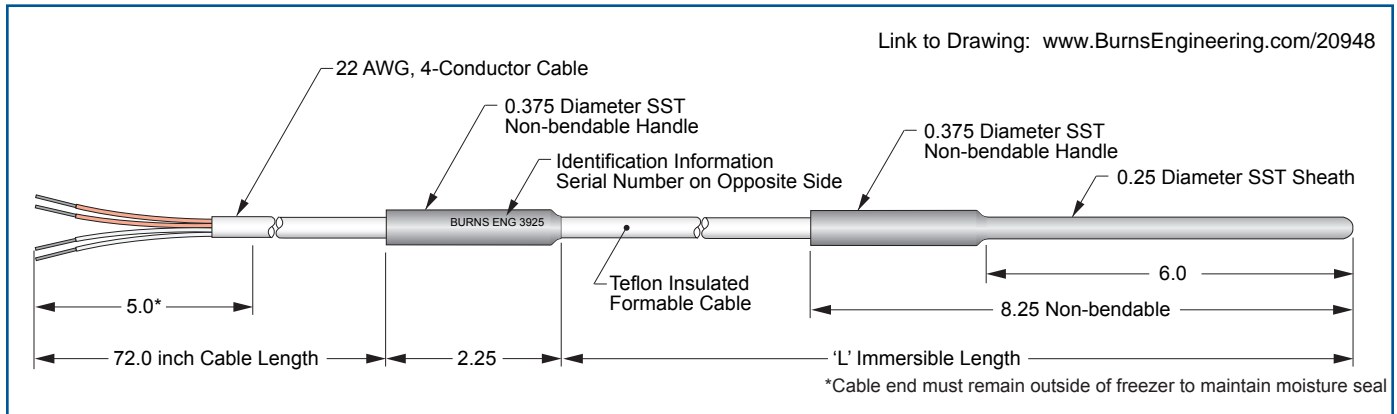

'L' Immersible Length, in inches		Min Length	Max Length
-24	24.0 inches		
-36	36.0 inches		
Specify 'L' Immersible Length in inches		12.0"	36.0"

20948

Basic Order Codes

(Leave blank if not required)

Options, see page 8

A Note About Formable Cable

The formable section of this sensor allows for repeatable depth measurements to minimize effects from temperature gradients. Just form the cable over the edge of the freezer or storage rack and it holds the shape in between calibrations