



- Reliable control of motors and other loads in motor starters and power distribution boards
- Reliable protection of motors in conjunction with the overload relay
- International approvals for worldwide use
- Ultimate flexibility thanks to wide-range coil voltages
- Large cable dia. range of the main terminals

J

MY R. STAHL 8550C



R. STAHL's Series 8550 contactor is a motor load contactor for use in motor starters up to 37 kW/50 hp at 400 or 480 V and in other power-based applications. It switches AC-3, AC-4, AC-5 and AC-6 loads just as reliably as AC-1 operating currents. Values are also available for DC-1, -3 and -5. With just three coil voltage ranges, control voltages of 20 to 280 volts are covered. Up to four auxiliary contacts are optionally available. Supplemented by the moulded case circuit breaker and overload relay also available in this series, motor starters up to 37 kW/50 hp at 400 or 480 V are available (other powers available on request).

	NEC® 500 CE Code Appendix J					
	Class I		Class II		Class III	
Division	1	2	1	2	1	2
Ex interface						
Installation in		•*				

	CE Code Section 18					
	NEC® 505			NEC® 506		
	Class I					
Zone	0	1	2	20	21	22
Ex interface						
Installation in		•	•			

	IECEX / ATEX					
Zone	0	1	2	20	21	22
Ex interface						
Installation in		•	•			

\* Restrictions, see certificate

Selection Table				
Rated operational current	80 A			
Connection cross-section AWG	4 ... 4/0 AWG			
Connection cross-section	25 – 95 mm²			
Rated actuating voltage		Product Type	Art. No.	Weight lb
20 to 33 V AC/DC		8550/1-CT-GLS3-80-95-U1S-22	287707	9.26 lb
83 to 155 V AC/DC		8550/1-CT-GLS3-80-95-U2S-22	287708	9.26 lb
175 to 280 V AC/DC		8550/1-CT-GLS3-80-95-U3S-22	283726	9.26 lb
Rated operational current	80 A			
Connection cross-section AWG	8 ... 4 AWG			
Connection cross-section	10 – 25 mm²			
Rated actuating voltage		Product Type	Art. No.	Weight lb
20 to 33 V AC/DC		8550/1-CT-GLS3-80-25-U1S-22	307519	9.26 lb
83 to 155 V AC/DC		8550/1-CT-GLS3-80-25-U2S-22	307520	9.26 lb
175 to 280 V AC/DC		8550/1-CT-GLS3-80-25-U3S-22	307561	9.26 lb

Technical Data	
Explosion Protection	
Application range (Zone) note	For use in Zone 21/22 when protected by Ex tb/tc enclosure
FMus certificate	FM22US0011U

### Technical Data

#### Explosion Protection

cFM certificate	FM22CA0006U
Marking FMus	Class I, Div. 2, Groups A,B,C,D; Class I, Zone 1, AEx db eb IIC Gb;
Marking cFM	Class I, Zone 1, Ex db eb IIC Gb; Class I, Div. 2, Groups A,B,C,D;
IECEX gas explosion protection	Ex db eb IIC Gb
Certificates	ATEX (FM), Brazil (ULB), Canada (FM), IECEX (FM), USA (FM)

#### Electrical Data

Rated operational voltage	max. 690 V
Idle operating frequency	5000 1/h
Operating frequency AC-3	500 1/h
Main contacts	3-pole (3 NO)
Auxiliary contacts	4 (2 NO + 2 NC)

#### Ambient Conditions

Ambient temperature °F	-13 °F ... +140 °F
Ambient temperature °C	-25 °C ... +60 °C

#### Mechanical Data

Degree of protection (IP)	IP20
Enclosure material	Thermoplast
Auxiliary contact connection cross section AWG	18 ... 14 AWG
Auxiliary contact connection cross section	0.75 ... 2.5 mm <sup>2</sup>

### Technical Drawings – Subject to Alterations

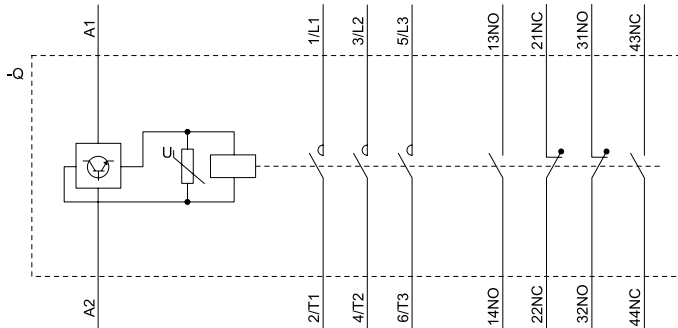

Circuit diagram of the device

Dimensional Drawings (All Dimensions in mm [inches]) – Subject to Alterations

J

