

- Universal use for transmitters and mA sources (4-wire transmitter)
- Slim design – 12.5 mm wide – for one- and two-channel versions
- Can be used for safety levels up to SIL 2 (IEC/EN 61508)

07 b

## MY R. STAHL 9260A



Series 9260 Ex i transmitter supply units can be used for the intrinsically safe operation of transmitters or intrinsically safe mA sources such as 4-wire transmitters. The device allows HART signals to be transmitted in both directions. The portfolio includes one- and two-channel devices and a variant for signal duplication.

	NEC® 500 CE Code Appendix J						CE Code Section 18 NEC® 505   NEC® 506						IECEX / ATEX							
	Class I		Class II		Class III		Class I			Class I			0		1		2			
Division	1	2	1	2	1	2	Zone	0	1	2	20	21	22	Zone	0	1	2	20	21	22
Ex interface	•	•	•	•	•	•	Ex interface	•	•	•				Ex interface	•	•	•	•	•	•
Installation in		•					Installation in		•					Installation in		•				

Selection Table							
Output version (control)		0/4 to 20 mA active/passive with HART					
Number of channels	Input signal	Output A	Output B	Connection type	Product Type	Art. No.	Weight lb
1	0/4 to 20 mA with HART	0/4 to 20 mA	–	Screw terminal	9260/13-11-10s	261384	0.41 lb
		0/4 to 20 mA	–	Spring clamp terminal	9260/13-11-10k	261387	0.41 lb
Output version (control)		0/4 to 20 mA active/with HART					
Number of channels	Input signal	Output A	Output B	Connection type	Product Type	Art. No.	Weight lb
1	0/4 to 20 mA with HART	0/4 to 20 mA	0/4 to 20 mA (without HART)	Screw terminal	9260/19-11-10s	261385	0.43 lb
		0/4 to 20 mA	0/4 to 20 mA (without HART)	Spring clamp terminal	9260/19-11-10k	261388	0.43 lb
2	4 to 20 mA with HART	4 to 20 mA	4 to 20 mA	Screw terminal	9260/23-11-10s	261386	0.43 lb
		4 to 20 mA	4 to 20 mA	Spring clamp terminal	9260/23-11-10k	261389	0.43 lb

Technical Data			
Variant	9260/13-11-10	9260/19-11-10	9260/23-11-10
Explosion Protection			
cULus certificate	E81680	E81680	E81680
Marking cULus	Class I, Div. 2, Groups A,B,C,D; Class I, Zone 2, AEx/Ex nA Group IIC AIS Class I,II,III, Div. 1, Groups A,B,C,D,E,F,G; Class I, Zone 0, [Ex ia] IIC T4 any mounting pos. Ta = 60°C See Doc. 9260 6 031 001 3	Class I, Div. 2, Groups A,B,C,D; Class I, Zone 2, AEx/Ex nA Group IIC AIS Class I,II,III, Div. 1, Groups A,B,C,D,E,F,G; Class I, Zone 0, [Ex ia] IIC T4 any mounting pos. Ta = 60°C See Doc. 9260 6 031 001 3	Class I, Div. 2, Groups A,B,C,D; Class I, Zone 2, AEx/Ex nA Group IIC AIS Class I,II,III, Div. 1, Groups A,B,C,D,E,F,G; Class I, Zone 0, [Ex ia] IIC T4 any mounting pos. Ta = 60°C See Doc. 9260 6 031 001 3

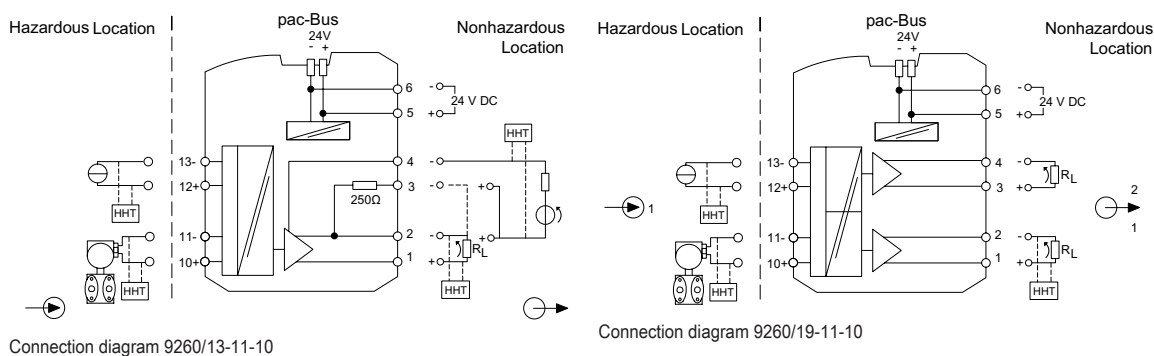

Technical Data			
Variant	9260/13-11-10	9260/19-11-10	9260/23-11-10
<b>Explosion Protection</b>			
IECEX gas explosion protection	Ex ec [ia Ga] IIC T4 Gc	Ex ec [ia Ga] IIC T4 Gc	Ex ec [ia Ga] IIC T4 Gc
IECEX dust explosion protection	[Ex ia Da] IIIC	[Ex ia Da] IIIC	[Ex ia Da] IIIC
IECEX firedamp protection	[Ex ia Ma] I	[Ex ia Ma] I	[Ex ia Ma] I
Certificates	ATEX (BVS), Canada (UL), China (CQM), IECEx (BVS), India (PESO), Korea (KTL), SIL (BVS), USA (UL)	ATEX (BVS), Canada (UL), China (CQM), IECEx (BVS), India (PESO), Korea (KTL), SIL (BVS), USA (UL)	ATEX (BVS), Canada (UL), China (CQM), IECEx (BVS), India (PESO), Korea (KTL), SIL (BVS), USA (UL)
Ship approval	DNV	DNV	DNV
<b>Safety Data</b>			
Max. voltage $U_i/V_{oc}$	25.2 V	25.2 V	25.2 V
Max. current $I_i/I_{sc}$	93 mA	93 mA	93 mA
Max. power $P_o$	587 mW	587 mW	587 mW
Safety-related max. voltage	253 V AC	253 V AC	253 V AC
<b>Functional Safety</b>			
SIL	2	2	2
<b>Electrical Data</b>			
LFD relay	No	No	No
<b>Input</b>			
Input function	Isolation amplifier Transmitter power unit	Isolation amplifier Transmitter power unit	Transmitter power unit
Input signal	0/4 to 20 mA with HART	0/4 to 20 mA with HART	4 to 20 mA with HART
Supply voltage for transmitter	$\geq 16$ V at 20 mA	$\geq 16$ V at 20 mA	$\geq 16$ V at 20 mA
<b>Output</b>			
Load resistance $R_L$	0 ... 1000 $\Omega$	0 ... 450 $\Omega$	0 ... 450 $\Omega$
Deviation	$\leq 0,1$ %	$\leq 0,1$ %	$\leq 0,1$ %
Temperature influence error limits	$< 0,1\%$ / 10 K	$< 0,1\%$ / 10 K	$< 0,1\%$ / 10 K
<b>Ambient Conditions</b>			
Ambient temperature °F	-40 °F ... +158 °F (Single device) -40 °F ... +140 °F (Group assembly)	-40 °F ... +158 °F (Single device) -40 °F ... +140 °F (Group assembly)	-40 °F ... +158 °F (Single device) -40 °F ... +140 °F (Group assembly)
Ambient temperature °C	-40 °C ... 70 °C (Single device) -40 °C ... 60 °C (Group assembly)	-40 °C ... 70 °C (Single device) -40 °C ... 60 °C (Group assembly)	-40 °C ... 70 °C (Single device) -40 °C ... 60 °C (Group assembly)
Storage temperature °F	-40 °F ... +176 °F	-40 °F ... +176 °F	-40 °F ... +176 °F
Storage temperature °C	-40 °C ... 80 °C	-40 °C ... 80 °C	-40 °C ... 80 °C
<b>Mounting / Installation</b>			
Mounting type	DIN rail NS35/15, NS35/7.5	DIN rail NS35/15, NS35/7.5	DIN rail NS35/15, NS35/7.5

**Technical Drawings – Subject to Alterations**

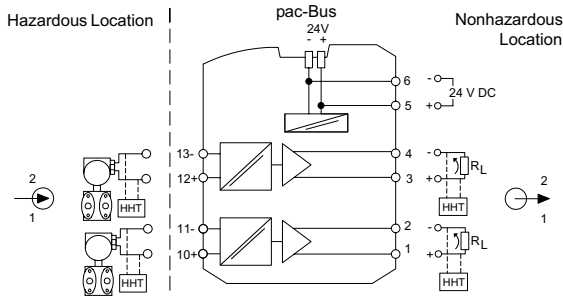



Connection diagram 9260/23-11-10

Accessories				
Figure	Description	Product Type	Art. No.	Weight lb
<b>Supply module</b>				
	Redundant supply of 24 V DC auxiliary power (with fuse) and reading out the collective error message from Series 92xx ISpac modules which support this function. Screw terminal connection	9193/21-11-11s	268183	0.3
	Redundant supply of 24 V DC auxiliary power (with fuse) and reading out the collective error message from Series 92xx ISpac modules which support this function. Spring clamp terminal connection	9193/21-11-11k	268184	0.3
<b>pac-Bus</b>				
	Wiring auxiliary power and collective error message	9294/31-12	262928	0.01

**Dimensional Drawings (All Dimensions in mm [inches]) – Subject to Alterations**

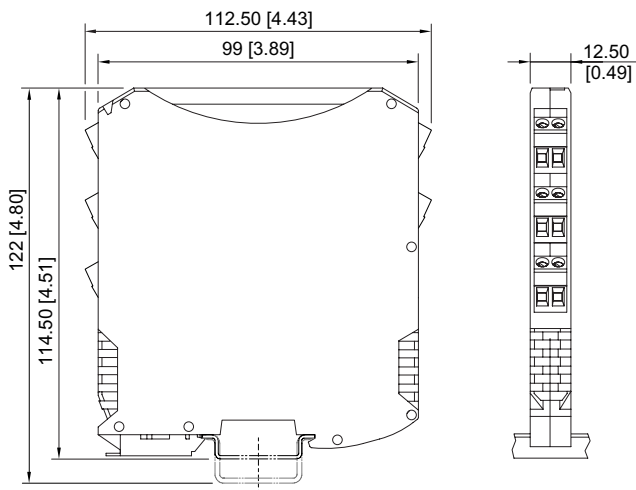

ISpac Series 9260, 9265, 9270, 9275, 9276, 9282 with screw terminal