

STAHL



Ready-Term® 8125 Terminal Boxes Features:

- *Pre-Configured with terminals mounted*
- *Materials:
Stainless Steel or
Carbon Steel*
- *Six enclosure sizes with
different depths*
- *For power and control
circuits*
- *For I.S. circuits with
blue terminals*
- *Entry hardware
optional*
- *Field installation
possible*

PRE-CONFIGURED STAINLESS AND CARBON STEEL TERMINAL BOXES
WITH PHOENIX TERMINALS

STAHL

CLASSIFICATIONS OF 8125/1

NEC- Class I, Zones 1 & 2 AEx e II T6/T5
Class I, Division 2, Groups A,B,C,D
Class II, Division 2, Groups F,G
Class III

Types:

- stainless steel version
3, 4 & 4X; IP66,
- carbon steel version, painted
3 & 4; IP66,



File No. E177642

CEC- Class I, Zones 1 & 2 Ex e II T6/T5
Class I, Division 2, Groups A,B,C,D
Class II, Divisions 1 & 2, Groups E,F,G
Class III



CSA ENCLOSURES

- stainless steel version
Types 3, 4 & 4X; IP66
- carbon steel version, painted
Types 3 & 4; IP66

File No. LR 99480



II 2G Ex e II T6/T5
II 2G Ex ia/ib IIC T6
PTB 00 ATEX 3116
II 2D Ex td A21 IP66, T80°C/T95°C

IECEX

Ex e II T6/T5
Ex ia/ib IIC T6
Ex td T21 IP66 T80°C
IECEX PTB 06.0060

Max. Voltage 600 AC/DC

Ambient Temperature Range:

- +40°C (+104°F) Max. T6
- +55°C (+131°F) Max. T5
- 20°C (-4°F) Min.

FEATURES

The Ready-Term® 8125 Series of terminal boxes are made of 316L stainless sheet steel or painted carbon steel. They offer a one-source solution to the time-consuming process of providing ready to install terminal boxes for hazardous locations. With its single part number solution, the Ready-Term® 8125 Series eliminates the inconvenience of purchasing the enclosure and individual parts. This Series is supplied with the indicated quantity of individually numbered terminals for each size of enclosure, fully certified and ready to be installed.

Ordering Information

TERM. QTY.	WIRE RANGE AWG.	TERM. SIZE mm2	MAX. AMPS. PER TERM.	CATALOG NUMBER		CATALOG NUMBER		ENCLOSURE ORIENTATION
				FOR POWER & CONTROL CIRCUITS	GRND. WIRE CON-NECTIONS	FOR INTRINSICALLY SAFE CIRCUITS	PA WIRE CON-NECTIONS	
15	26-12	2.5	20	8125/1041-2DP-12015*	8	8125/2041-2DP-12015*	8	
18	26-12	2.5	20	8125/1051-2DP-12018	14	8125/2051-2DP-12018	14	
15	26-10	4	30	8125/1051-2DP-10015	14	8125/2051-2DP-10015	14	
9	20-6	10	65	8125/1051-2DP-06009	12	-	-	
24	26-12	2.5	20	8125/1061-2DP-12024	14	8125/2061-2DP-12024	14	
21	26-10	4	30	8125/1061-2DP-10021	14	8125/2061-2DP-10021	14	
9	20-6	10	65	8125/1061-2DP-06009	12	-	-	
45	26-12	2.5	20	8125/1071-2DP-12045	14	8125/2071-2DP-12045	14	
36	26-10	4	30	8125/1071-2DP-10036	14	8125/2071-2DP-10036	14	
24	20-6	10	65	8125/1071-2DP-06024	12	-	-	

To Select Painted Steel Enclosures change 2 to 1
To Select Weidmuller Terminals change P to W
For dimensional data see page C20
*With Phoenix terminals only

"Hazardous Location" Conduit Hubs

HUB, NPT THREAD SIZE	CATALOG NUMBER
1/2"	8166/11-01-NE
3/4"	8166/11-02-NE
1"	8166/11-03-NE
1 1/4"	8166/11-04-NE
1 1/2"	8166/11-05-NE
2"	8166/11-06-NE
2 1/2"	8166/11-07-NE
3"	8166/11-08-NE



Ready-Term® 8125 Terminal Boxes

PRE-CONFIGURED STAINLESS AND CARBON STEEL TERMINAL BOXES
WITH PHOENIX TERMINALS

Ordering Information

TERM. QTY.	WIRE RANGE AWG.	TERM. SIZE mm ²	MAX. AMPS. PER TERM.	CATALOG NUMBER		CATALOG NUMBER		ENCLOSURE ORIENTATION
				FOR POWER & CONTROL CIRCUITS	GRND. WIRE CONNECTIONS	FOR INTRINSICALLY SAFE CIRCUITS	PA WIRE CON. CONNECTIONS	
45	26-12	2.5	20	8125/1073-2DP-12045	14	8125/2073-2DP-12045	14	
36	26-10	4	30	8125/1073-2DP-10036	14	8125/2073-2DP-10036	14	
24	20-6	10	65	8125/1073-2DP-06024	12	-	-	
18	16-4	16	85	8125/1073-2DP-04018	6	-	-	
12	14-1/0	35	150	8125/1073-2DP-1/012	6	-	-	
45	26-12	2.5	20	8125/1083-2DP-12045	36	8125/2083-2DP-12045	36	
36	26-10	4	30	8125/1083-2DP-10036	36	8125/2083-2DP-10036	36	
24	20-6	10	65	8125/1083-2DP-06024	24	-	-	
18	16-4	16	85	8125/1083-2DP-04018	6	-	-	
12	14-1/0	35	150	8125/1083-2DP-1/012	6	-	-	
90	26-12	2.5	20	8125/1083-2DP-12090	72	8125/2083-2DP-12090	72	
72	26-10	4	30	8125/1083-2DP-10072	72	8125/2083-2DP-10072	72	
48	20-6	10	65	8125/1083-2DP-06048	48	-	-	
90	26-12	2.5	20	8125/1093-2DP-12090	72	8125/2093-2DP-12090	72	
72	26-10	4	30	8125/1093-2DP-10072	72	8125/2093-2DP-10072	72	
48	20-6	10	65	8125/1093-2DP-06048	48	-	-	
36	16-4	16	85	8125/1093-2DP-04036	12	-	-	
24	14-1/0	35	150	8125/1093-2DP-1/024	12	-	-	
180	26-12	2.5	20	8125/1093-2DP-12180	72	8125/2093-2DP-12180	72	
144	26-10	4	30	8125/1093-2DP-10144	72	8125/2093-2DP-10144	72	
96	20-6	10	65	8125/1093-2DP-06096	48	-	-	

To Select Painted Steel Enclosures change 2 to 1
To Select Weidmuller Terminals change P to W
For dimensional data see page C20

TERMINATION

STAHL

CLASSIFICATIONS of 8125/1

NEC- Class I, Zones 1 & 2 AEx e II T6/T5
Class I, Division 2, Groups A,B,C,D
Class II, Division 2, Groups F,G
Class III

Types: See Page C15
File No. E177642

CEC- Class I, Zones 1 & 2 Ex e II T6/T5
Class I, Division 2, Groups A,B,C,D
Class II, Divisions 1 & 2, Groups E,F,G
Class III

CSA ENCLOSURES: See Page C15
File No. LR 99480

II 2G Ex e II T6/T5
II 2G Ex ia/ib IIC T6
PTB 00 ATEX 3116
II 2D Ex td A21 IP66, T80°C/T95°C

IECEX
Ex e II T6/T5
Ex ia/ib IIC T6
Ex td T21 IP66 T80°C
IECEX PTB 06.0060

Max. Voltage 600 AC/DC

Ambient Temperature Range:
See Page C15

In addition to the various North American applications, this Series is PTB certified for use in Zones 1 and 2. The design conforms to EN/IEC 60 079-7 and many others. Consult factory.

APPLICATION

Typical applications include junction boxes for petrochemical plants, waste treatment facilities, oil refineries and other major industrial plants. As a product with certifications recognized globally, the Ready-Term® 8125 Series is well suited for original equipment manufacturers who market throughout the world.

The 8125/1 Series of terminal boxes is intended for use on circuits designed for power and motor control applications.

The 8125/2 Series is intended for use with intrinsically safe circuits. These enclosures are outfitted with blue terminals to provide an indication to field personnel that the circuits are intrinsically safe and should not be confused with non-intrinsically safe circuits.

These enclosures make it necessary for the metal entry hardware to be bonded to the ground system. Use the suitable 8166/11 conduit hubs specified in the hub table on page C17.

Custom enclosures can be configured upon request.

The following modifications are available:

- Stainless Steel hinges for right or left side (specify)
- Conduit hubs 8166/11 (specify)
- Cable glands (specify)
- Close-up plugs (specify)
- Flange plates (specify)
- Screw-Type Terminals up to 600MCM
- Cage Clamp Terminals up to 8AWG

INSTALLATION OF ENTRY HARDWARE

Method 1: Enclosures with flange plates using threaded openings through the flange plate and standard locknuts. Flange plates must be connected to the internal grounding system using jumper wires.

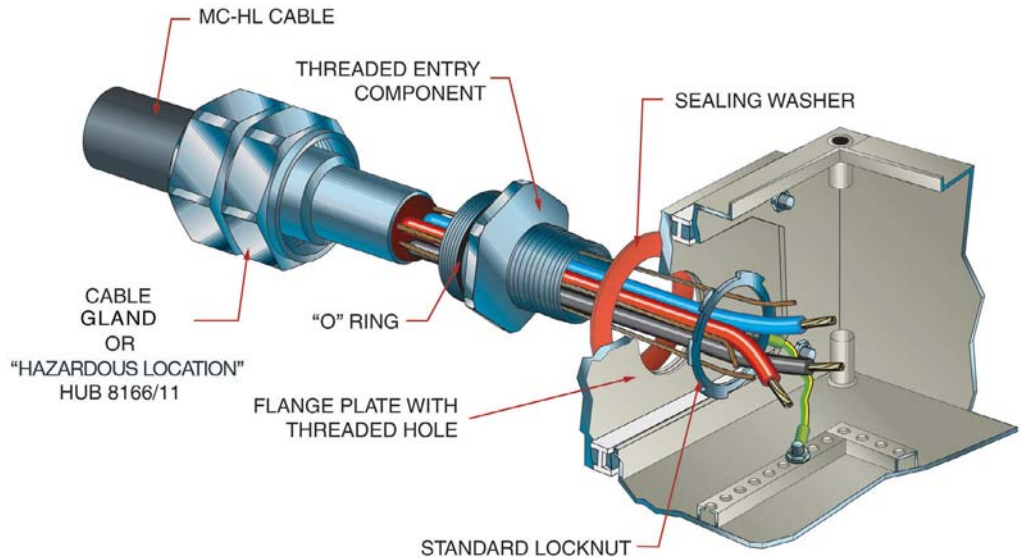

The 8125 Series of metallic terminal boxes are available with factory installed conduit hubs for conduit installation or with cable glands for cable installation.

Approved and suitable for the location entry hardware can also be field installed.

These enclosures make it necessary for the metal cable glands or conduit hubs to be bonded to the ground system. This can be accomplished by installing enclosures with flange plates according to Method 1 (shown on the upper half of this page), or enclosures without flange plates according to Method 2 (shown on the lower half of this page).

For cable glands see section J.

Table for max. numbers of entry openings either installed with conduit hubs 8166/11 or cable glands (see page C18).

CAUTION:

The max. possible number of entries which can be installed on the sides of the enclosures depends on the number of terminal columns installed. With horizontally installed columns, there are no side entries possible or only limited, depending on enclosure size. With vertically installed columns there are no bottom or top entries possible, or only limited, depending on enclosure size.

Method 2: Enclosures without flange plates using a hole "through the enclosure" with an "increased safety" grounding locknut.

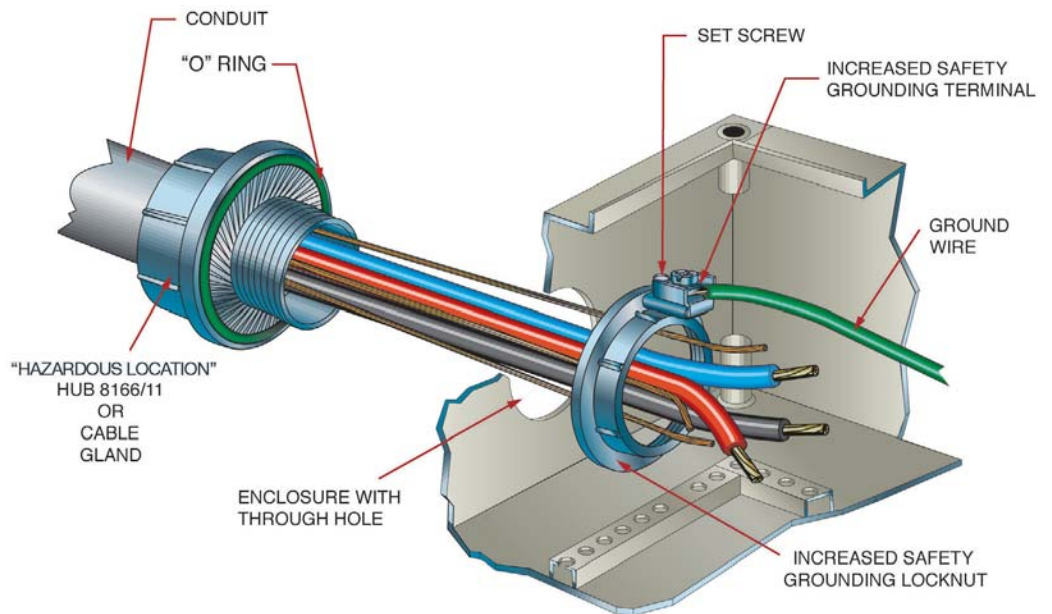

These locknuts must be bonded between each other and to the grounding system using a jumper wire.

After the entry hardware is installed, connect the appropriate conduit or cable.

8125 Series Terminal Boxes

TERMINATION

INSTALLATION OF 8166/11 CONDUIT HUBS OR TMCW CABLE GLANDS

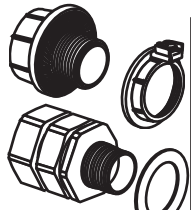

8125/.041

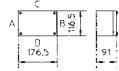

Size	w/o flanges		with flanges	
	A/B	C/D	A/B	C/D
1/2"	2	3	-	2
3/4"	1	3	-	2
1"	1	2	-	-
1-1/4"	1	2	-	-
1-1/2"	-	-	-	-
2"	-	-	-	-
2-1/2"	-	-	-	-
3"	-	-	-	-

8125/.051

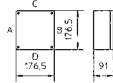

Size	w/o flanges		with flanges	
	A/B	C/D	A/B	C/D
1/2"	3	3	2	2
3/4"	3	3	2	2
1"	2	2	-	-
1-1/4"	2	2	-	-
1-1/2"	-	-	-	-
2"	-	-	-	-
2-1/2"	-	-	-	-
3"	-	-	-	-

8125/.061

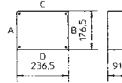

Size	w/o flanges		with flanges	
	A/B	C/D	A/B	C/D
1/2"	3	5	2	2
3/4"	3	4	2	2
1"	2	3	-	-
1-1/4"	2	2	-	-
1-1/2"	-	-	-	-
2"	-	-	-	-
2-1/2"	-	-	-	-
3"	-	-	-	-

8125/.063

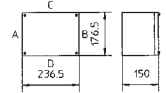

Size	w/o flanges		with flanges	
	A/B	C/D	A/B	C/D
1/2"	6	10	4	4
3/4"	5	8	4	4
1"	4	6	2	2
1-1/4"	3	4	1	1
1-1/2"	2	3	1	1
2"	1	2	1	1
2-1/2"	1	2	1	1
3"	1	1	-	-

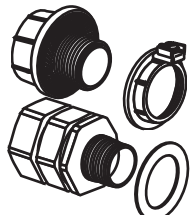

8125/.071

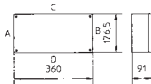

Size	w/o flanges		with flanges	
	A/B	C/D	A/B	C/D
1/2"	3	8	2	4
3/4"	3	6	2	4
1"	2	5	-	-
1-1/4"	2	4	-	-
1-1/2"	-	-	-	-
2"	-	-	-	-
2-1/2"	-	-	-	-
3"	-	-	-	-

8125/.073

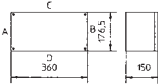

Size	w/o flanges		with flanges	
	A/B	C/D	A/B	C/D
1/2"	6	16	4	10
3/4"	5	12	4	8
1"	4	10	2	4
1-1/4"	3	7	1	4
1-1/2"	2	5	1	3
2"	1	4	1	2
2-1/2"	1	3	1	2
3"	1	2	-	-

8125/.081

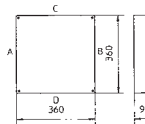

Size	w/o flanges		with flanges	
	A/B	C/D	A/B	C/D
1/2"	8	8	4	4
3/4"	6	6	4	4
1"	5	5	-	-
1-1/4"	4	4	-	-
1-1/2"	-	-	-	-
2"	-	-	-	-
2-1/2"	-	-	-	-
3"	-	-	-	-

8125/.083

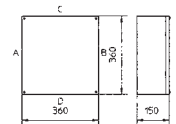

Size	w/o flanges		with flanges	
	A/B	C/D	A/B	C/D
1/2"	16	16	10	10
3/4"	12	12	8	8
1"	10	10	4	4
1-1/4"	7	7	4	4
1-1/2"	5	5	3	3
2"	4	4	2	2
2-1/2"	3	3	2	2
3"	2	2	-	-

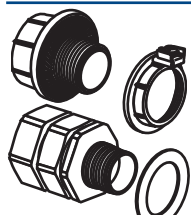

8125/.085

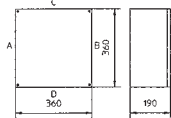

Size	w/o flanges		with flanges	
	A/B	C/D	A/B	C/D
1/2"	23	23	10	10
3/4"	17	17	8	8
1"	12	12	4	4
1-1/4"	9	9	4	4
1-1/2"	8	8	3	3
2"	5	5	2	2
2-1/2"	3	3	2	2
3"	3	3	-	-

8125/.091

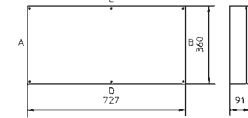

Size	w/o flanges		with flanges	
	A/B	C/D	A/B	C/D
1/2"	8	17	4	8
3/4"	6	14	4	8
1"	5	10	-	-
1-1/4"	4	8	-	-
1-1/2"	-	-	-	-
2"	-	-	-	-
2-1/2"	-	-	-	-
3"	-	-	-	-

8125/.093



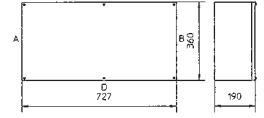

Size	w/o flanges		with flanges	
	A/B	C/D	A/B	C/D
1/2"	16	34	10	20
3/4"	12	28	8	16
1"	10	20	4	8
1-1/4"	7	12	4	8
1-1/2"	5	10	3	6
2"	4	8	2	4
2-1/2"	3	6	2	4
3"	2	5	-	-

8125/.095

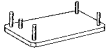
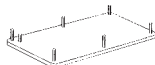

Size	w/o flanges		with flanges	
	A/B	C/D	A/B	C/D
1/2"	23	46	10	20
3/4"	17	33	8	16
1"	12	23	4	8
1-1/4"	9	20	4	8
1-1/2"	8	16	3	6
2"	5	11	2	4
2-1/2"	3	7	2	4
3"	3	6	-	-

PARTS AND ACCESSORIES

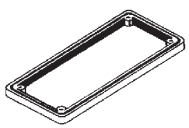
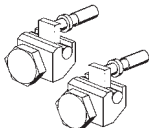
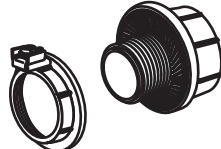
DESIGNATION	ILLUSTRATION	DESCRIPTION	CATALOG NUMBER
Flange Plate Size 1		5" x 2.7" x 0.2" (128 x 68 x 5 mm) carbon steel 316 stainless steel Can be fitted in Enclosures Sides 8125/*051 A/B/C/D 8125/*061 A/B/C/D 8125/*071 A/B/C/D 8125/*S71 C/D 8125/*081 A/B/C/D	134126 135051
Flange Plate Size 2		10.5" x 5" x 0.2" (266 x 128 x 5 mm) carbon steel 316 stainless steel Can be fitted in Enclosures Sides 8125/*073 C/D 8125/*083; /*085 A/B/C/D 8125/*093; /*095 A/B/C/D	134245 135093
Flange Plate Size 3		5" x 5" x 0.2" (126 x 126 x 5 mm) carbon steel 316 stainless steel Can be fitted in Enclosures Sides 8125/*073 A/B 8125/*063 C/D	134274 135125
Flange Plate Size 4		13.86" x 6.1" x 0.2" (352 x 155 x 5 mm) carbon steel 316 stainless steel Can be fitted in Enclosures Sides 8125/*085 A/B/C/D 8125/*095 A/B/C/D	134292 135145
Coupling Frames		Frame Sizes 0 2.68" x 2.68" (68 mm x 68 mm) 1 5.04" x 2.68" (128 mm x 68 mm) 2 10.47" x 4.96" (266 mm x 126 mm) 3 4.96" x 4.96" (126 mm x 126 mm) 4 13.86" x 6.1" (352 mm x 155 mm)	136012 135974 136031 136235 134289
Cover Hinges		8125 for retrofitting to enclosure Kit consists of: 2 hinges 3 hinges	134943 134949
Entry Hubs			8166/11 8166/11 (see page J1)



8125 Series Terminal Boxes

TERMINATION

DIMENSIONS

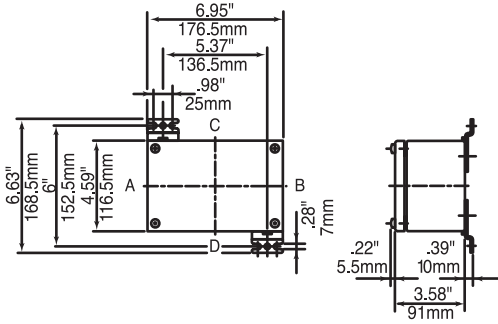

8125/041

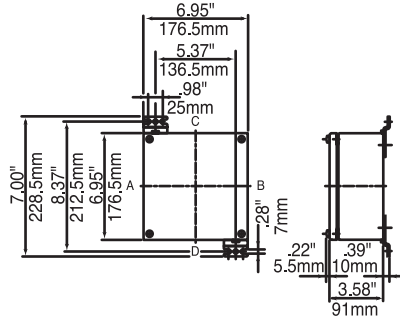

8125/051

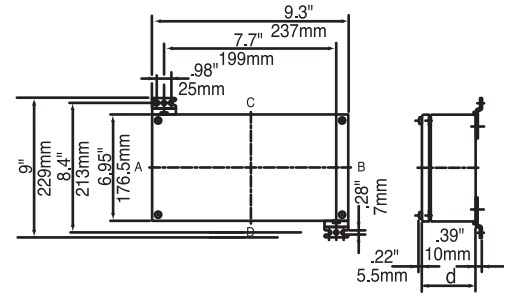

8125/060

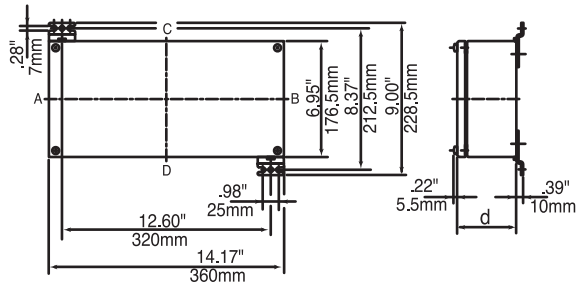

8125/070

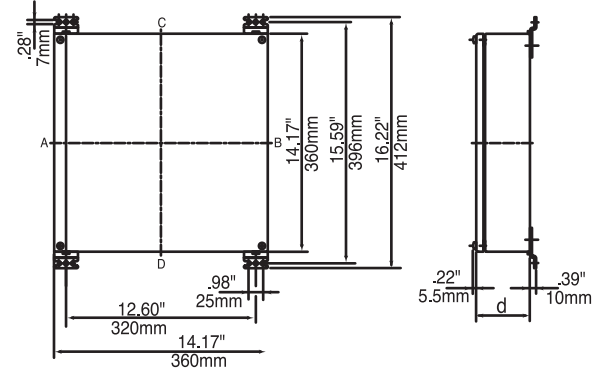

8125/080

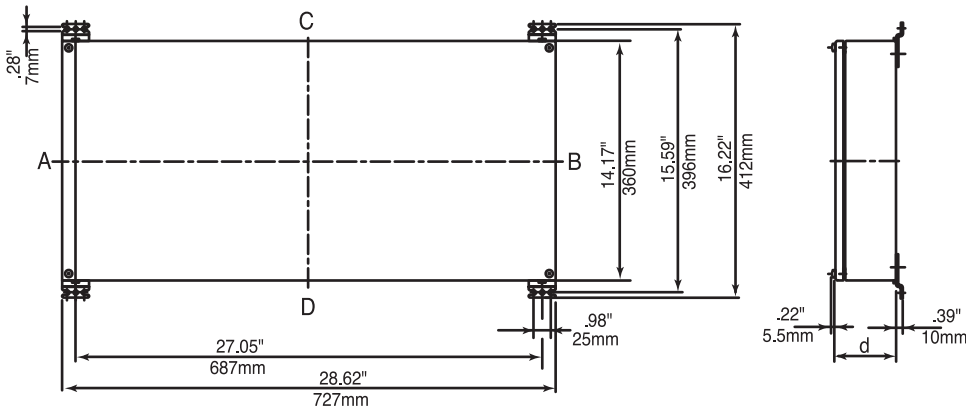

8125/090

Available Enclosure Depth (d)				
Enclosure Sizes	1	3	5	6
	3.58" 91mm	5.91" 150mm	7.48" 190mm	9.06" 230mm
8125/040	x	-	-	-
8125/050	x	-	-	-
8125/060	x	x	-	-
8125/070	x	x	-	-
8125/080	x	x	x	x
8125/090	x	x	x	-

Flange option:
Add to overall
dimensions.

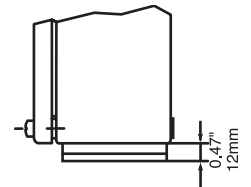



Electrical Capacity Tables

(only applicable for Class I, Zone 1)

In Class I, Zone 1 hazardous (classified) areas, heat produced by current in the wire inside an enclosure is a concern. Therefore, the continuous current of each current carrying conductor, the quantity and the size of the conductors inside a terminal enclosure needs to be limited. For each enclosure size, there is one table which shows the permissible values for that particular terminal enclosure.

How to use the electrical capacity tables:

- Determine the enclosure type you are dealing with.
- Reference the applicable electrical capacity table printed on pages C22-C25.



In the white area of the table the permitted numbers of current carrying conductors inside the enclosure are indicated (in and out counts two wires) depending on wire size and continuous current.



In the green shaded area of the table additional conductors/terminals are permitted up to the space limit of the enclosure. (see catalog pages C15 & C16)



In the area with red diagonal lines of the table no conductors/terminals are permitted.

Jumper links and ground wires can be neglected, in calculating the number of wires. These can be added whenever necessary.

Terminal Data

Terminal Type Phoenix	solid/stranded wire range	Max. voltage, V	Max. Amps	Torque lb-in
UT 2.5	26-12	600	20	5.3-7
UT 4	26-10	600	30	5.3-7
UT 6	24-8	600	50	13.3-16
UT 10	20-6	600	65	13.3-16
UT 16	16-4	600	85	22-26.5
UT 35	14-1/0	600	150	28-32.7
Terminal Type Weidmueller				
WDU 2.5	22-12	600	25	4.5-7.1
WDU 4	22-10	600	35	9
WDU 6	20-8	600	45	14.2
WDU 10	16-6	600	65	20.4
WDU 16	14-6	600	70	35
WDU 35	12-2	600	115	51
WDU 70	6-2/0	600	175	87
WDU 120	2-250	600	225	130
WFF 185	8-500	600	380	177
WFF 300	6-600	600	500	354
Terminal Type Wago				
281-691	28-12	600	20	N/A
281-991	28-12	600	20	N/A
282-691	24-10	600	30	N/A
283-691	24-6	600	65	N/A
284-691	24-8	600	50	N/A

EXAMPLE:

Enclosure type: 8125/1061-2DP-10021(see page C15).

The maximum physical quantity of terminals 26-10 AWG for this enclosure is 21.

Reference the table 8125/1061 on page C22, you will find that 18 wires 10 AWG with 30 Amps continuous current is the thermal limit of this enclosure.

Conclusion: To terminate 18 wires 9 terminals are needed, terminating two wires per terminal only. The remaining 12 terminals (21 - 9 = 12) can be used for low amperage circuits in the green shaded area of the table. Jumper links and ground wires can be neglected.

Mixed circuits of different wire sizes and current values are possible by applying the table values proportionally

i.e. enclosure table 8125/1061.

Wire Size AWG	Current Amps	Number of Current Carrying Conductors		Proportion
		Permissible	Actual	
12	20	24	12	50%
10	30	18	9	50%

100% max.