



EE870

Modular CO₂ Transmitter



Manual

YOUR PARTNER IN SENSOR TECHNOLOGY **E+E**

ELEKTRONIK[®]
Ges.m.b.H.

E+E Elektronik® Ges.m.b.H. doesn't accept warranty and liability claims neither upon this publication nor in case of improper treatment of the described products.

The document may contain technical inaccuracies and typographical errors. The content will be revised on a regular basis. These changes will be implemented in later versions. The described products can be improved and changed at any time without prior notice.

**© Copyright E+E Elektronik® Ges.m.b.H.
All rights reserved.**

**USA
FCC notice:**

This equipment has been tested and found to comply with the limits for a Class B digital device, pursuant to part 15 of the FCC Rules. These limits are designed to provide reasonable protection against harmful interference in a residential installation. This equipment generates, uses and can radiate radio frequency energy and, if not installed and used in accordance with the installation manual, may cause harmful interference to radio communications. However, there is no guarantee that interference will not occur in a particular installation. If this equipment does cause harmful interference to radio or television reception, which can be determined by turning the equipment off and on, the user is encouraged to try to correct the interference by one or more of the following measures:

- Reorient or relocate the receiving antenna.
- Increase the separation between the equipment and receiver.
- Connect the equipment into an outlet on a circuit different from that to which the receiver is connected.
- Consult the dealer or an experienced radio/TV technician for help.

Caution:

Any changes or modifications not expressly approved by the party responsible for compliance could void the user's authority to operate this device.

**CANADIAN
ICES-003 notification:**

This Device B digital apparatus complies with Canadian ICES-003.
Cet appareil numérique de la classe B est conforme à la norme NMB-003 du Canada.

Table of contents

GENERAL	3
IMPORTANT NOTES	4
CONNECTIONS / MOUNTING	4
TECHNICAL DATA	5
DIMENSIONS	5
HARDWARE SETTINGS	5
MODBUS MAP	6
OPERATION OUTDOORS	7
ACCESSORIES	7
SCOPE OF SUPPLY	7

GENERAL

For technical data, options and accessories please see EE870 data sheet and operation manual at www.epluse.com/EE870.

The modular CO₂ transmitter EE870 consists of following components:

- EE871 interchangeable CO₂ probe with E2 digital output. For technical data please see EE871 data sheet and operation manual (www.epluse.com/EE871)
For readjustment of EE871 please see data sheet and operation manual EE-PCS Product Configuration Software (www.epluse.com/EE-PCS)
- HA011014 converter board: The converter board supplies the EE871 CO₂ probe and converts its digital output signal into analogue outputs and Modbus RTU digital interface. The measured data is available simultaneously on the analogue outputs and on the Modbus interface. Technical data, setup and operations instructions for HA011014 are detailed in this document.
- Connecting cable between EE871 CO₂ probe and HA011014. EE870 scope of supply includes one of the following cables, as ordered:
 - HA010809..... 1 m length
 - HA010810 2 m length
 - HA010811 5 m length
 - HA010812 10 m length

IMPORTANT NOTES

- Connecting the supply voltage to the modbus terminals may destroy the device.
- The HA011014 converter board is supplied as a component and must be installed in accordance with the valid ESD guidelines and properly protected against environmental influences.

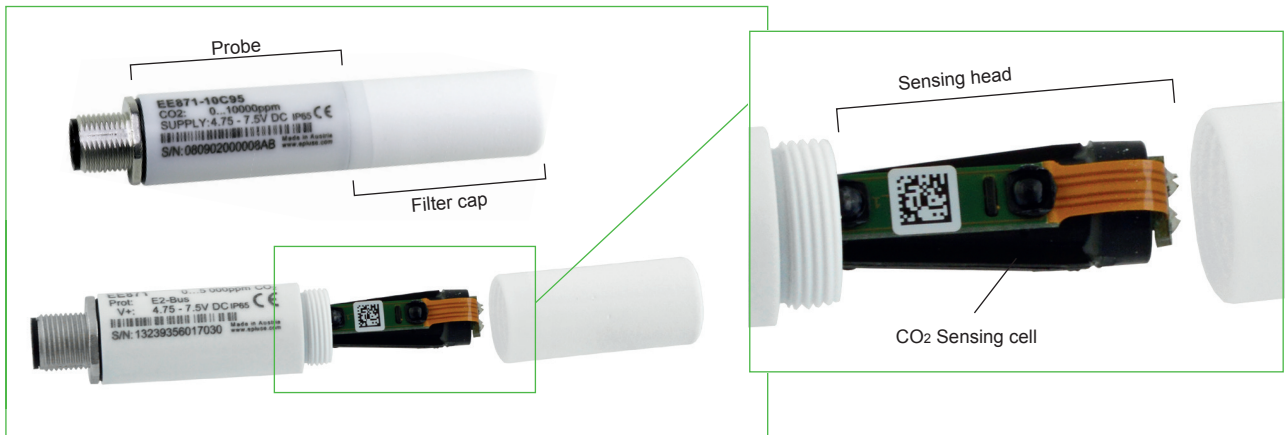

- The device shall not be exposed to extreme mechanical stress. The sensing head of the probe and mostly the sensing cell might not be exposed to any mechanical stress.
- The probe must be operated with the filter cap on at all times. Do not touch the sensing cell or electronics inside the sensing head.
- A long response time indicates a dirty filter cap, as it might happen in polluted applications. Do not attempt to clean the filter cap; it would only cause its clogging. Replace the filter cap by an E+E original one, order no. HA010116.
- While replacing the filter cap take utmost care to not touch the sensing cell and the electronics.
- This device is not appropriate for safety, emergency stop or other critical applications where device malfunction or failure could cause injury to human beings.

CONNECTIONS / MOUNTING

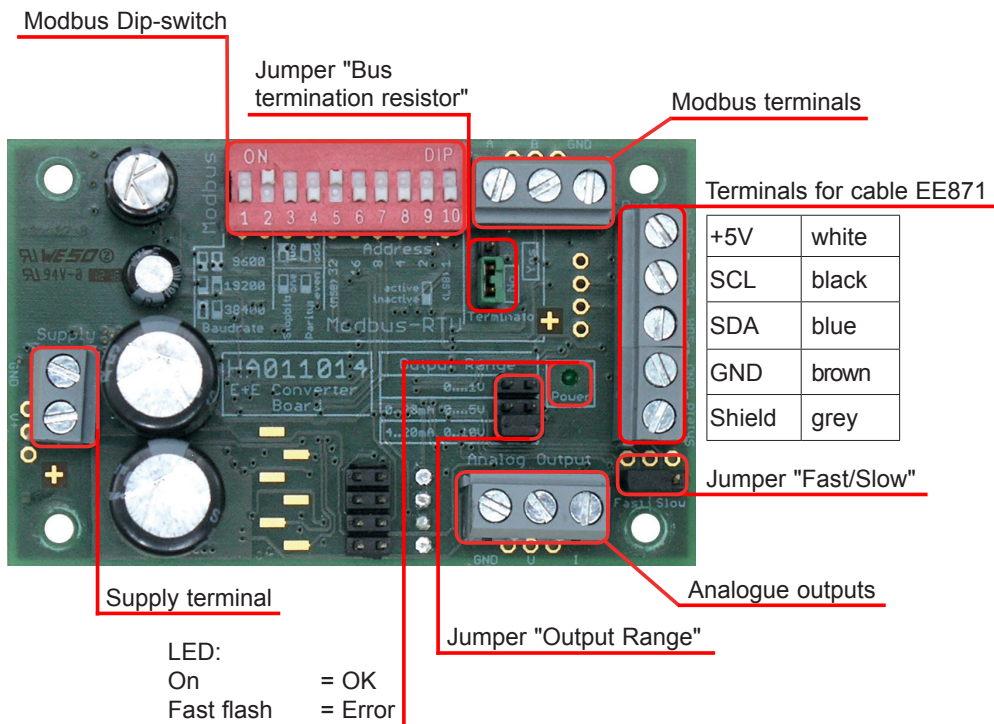

TECHNICAL DATA

Digital CO₂ Probe EE871

Measuring principle	Dual wavelength (non-dispersive infrared technology) NDIR	
Measurement range / Accuracy at 25 °C and 1013mbar ¹⁾ (77°F...14,69psi)	0...2000 ppm:	< ± (50 ppm + 2 % from the measured value)
	0...5000 ppm:	< ± (50 ppm + 3 % from the measured value)
	0...10,000 ppm:	< ± (100 ppm + 5 % from the measured value)
	0...3 %:	< ± (1,5 % from full scale + 2 % from the measured value)
	0...5 %:	< ± (1,5 % from full scale + 2 % from the measured value)
Response time t ₉₀	105 s with measured data averaging (smooth output) 60 s without measured data averaging	
Temperature dependency (-20...45 °C) (-4...113 °F)	0...2000 ppm:	
	0...5000 ppm:	typ. ± (1 + CO ₂ concentration [ppm] / 1000) ppm/°C
	0...10,000 ppm:	
	0...3 %:	
	0...5 %:	typ. -0,3 % from the measured value/°C
Housing / Protection class	Plastic PC / Housing IP65	
Cable length	max. 10 m (32 ft)	
Electromagnetic compatibility (Industrial environment)	EN61326-1 EN61326-2-3	



Conversion Board

Supply voltage	10-35 VDC / 10-28.8 VAC		
Supply current	120 mA at 24 VDC / 300 mA at 10 VDC		
Protection class	IP00		
Electrical connection	screw terminal size: 2.5 mm ²		
Analog outputs	0-1 V; 0-5 V; 0-10 V		
	-1 mA < I _L < 1 mA		
selectable by jumpers	0-20 mA; 4-20 mA R _L < 500 Ohm		
Resolution	12 bit		
Response time t ₉₀	60 s or 105 s selectable by jumpers		
Modbus RTU	setup with dip-switches (see operation manual)		
Temperature dependence	Voltage:	typ. ±0.2 mV/°C (0 – 1V) typ. ±0.5 mV/°C (0 – 5V) typ. ±0.6 mV/°C (0 – 10V)	
	Current:	typ. ±1 µA / °C	
EE870 Operating conditions	-40...60 °C (-40...140 °F)	0...100 % RH (not condensating)	85...110 kPa (12.33...15.95 psi)
EE870 Storage condition	-40...60 °C (-40...140 °F)	0...100 % RH (not condensating)	70...110 kPa (10.15...15.95 psi)

DIMENSIONS

Digital CO₂ Probe EE871

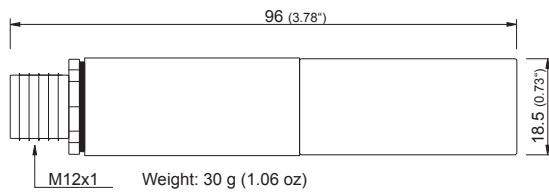

Conversion Board

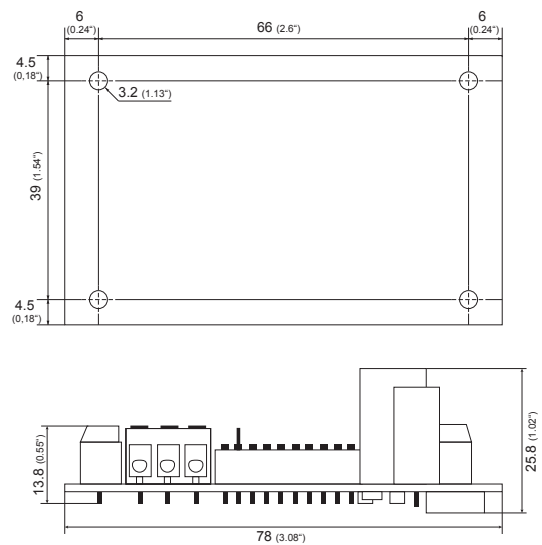

HARDWARE SETTINGS

Analogue-Output

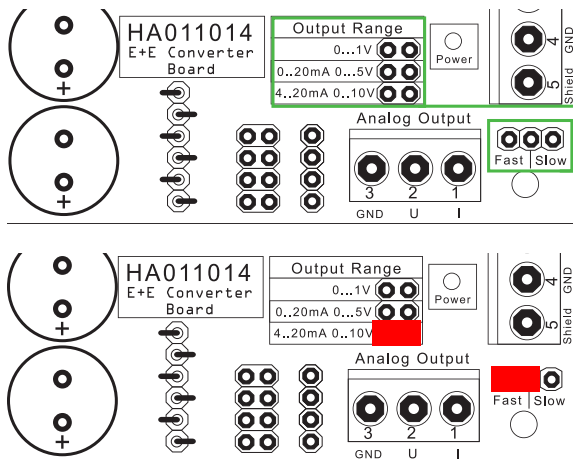

Jumper for setting the analogue output:

	Current	Voltage
○○	-	0-1 V
○○	0-20 mA	0-5 V
○○	4-20 mA	0-10 V

Jumper for setting the response time:

○○○	fast response time
○○○	slow response time

Example:

Jumper "Output Range" set to 0...10 V.

Jumper "Fast/Slow" set to "Fast"

Modbus-Interface

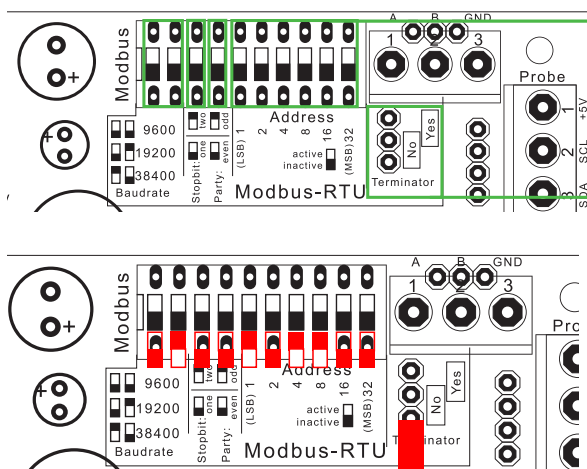

Dip-switch for Modbus settings

S1, S2	baud rate
S3	stopbit
S4	parity
S5 - S10	adresse of the converter

Jumper for termination resistor active/inactive

Example:

Dip-switch S1 and S2 "Baud rate" set on 19200

Dip-switch S3 "Stopbit" set on "one"

Dip-switch S4 "Parity" set on "even"

Dip-switch S5 - S10 "Address" set on "13"
(activate S5/S7/S8)

Jumper "Termination resistor" set on "No"

MODBUS MAP

Register address	Parameter name	Protocol address
0x00	Serial number	0
0x01		1
0x02		2
0x03		3
0x04		4
0x05		5
0x06		6
0x07		7
0x08	FW Version	8
0x09	Type number	9
0x0A		10
0x0B		11
0x0C		12
0x0D		13
0x0E		14
0x0F		15
0x10		16
0x11	Serial number	17
0x12		18
0x13		19
0x14		20
0x15		21
0x16		22
0x17		23
0x18		24

ASCII

ASCII

HIGH BYTE - main version
LOW BYTE - sub version

Register address	Parameter name	Protocol address
0x19	-	25
0x1A		26
0x1B		27
0x1C		28
0x1D	CO ₂ fast	29
0x1E		30
0x1F	CO ₂ slow	31
0x20		32
0x21	Gain Voltage	33
0x22		34
0x23	Offset Voltage	35
0x24		36
0x25	Gain Current	37
0x26		38
0x27	Offset Current	39
0x28		40
0x29	Measuring range	41
0x2A		42
0x2B		43
0x2C	Measuring range	44
0x2D	Analogue Output low (V)	45
0x2E		46
0x2F	Analogue Output high (V)	47
0x30		48
0x31	Slow or Fast	49
0x32		50

FLOAT

ASCII

OPERATION OUTDOORS

For outdoor applications, the probe of EE870 must be used with the radiation shield order no. HA010507, which protects the device against rain, snow, ice, and solar radiation. The converter board must be protected IP65 (NEMA4) or better.

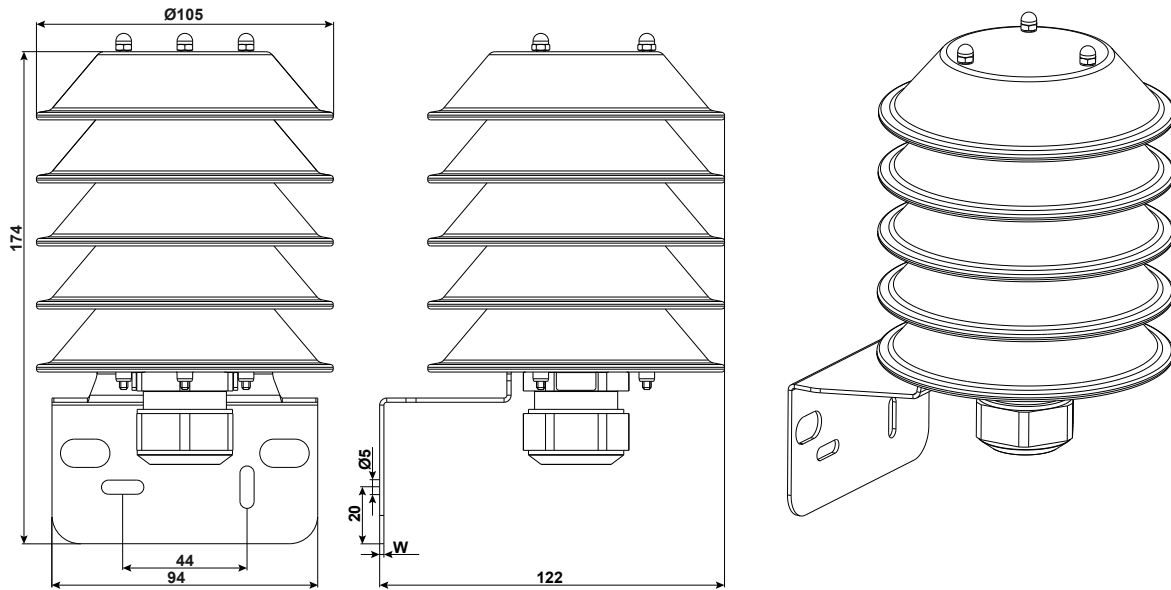

ACCESSORIES

Replacement probe EE871-HRxJ2
Cable M12 - flying leads (1 m (39.37") / 2 m (78.74") / 5 m (196.85") / 10 m (393.70"))
Mounting flange for probe
Radiation shield
PFTE Filter cap
Protection cap for the M12 cable socket
Protection cap for the M12 probe plug

see data sheet EE871
HA010809/10/11/12
HA010212
HA010507
HA010116
HA010781
HA010782

SCOPE OF SUPPLY

- EE871 probe according to ordering guide
- Test report according to DIN EN10204 - 2.2 for EE871
- Conversion board HA011014
- Connecting cable HA0108xx
- Operation manual
- Test report according to DIN EN10204 - 2.2 for conversion board



E+E ELEKTRONIK HEADQUARTERS

E+E ELEKTRONIK Ges.m.b.H.
Langwiesen 7, A-4209 Engerwitzdorf
Austria

Tel: +43 7235 605-0
Fax: +43 7235 605-8
info@epluse.at / www.epluse.com

E+E ELEKTRONIK SUBSIDIARIES

E+E ELEKTRONIK China / Beijing
Tel: +86 10 8499 2361
info@epluse.cn / www.epluse.cn

E+E ELEKTRONIK China / Shanghai
Tel: +86 21 6117 6129
info@epluse.cn / www.epluse.cn

E+E ELEKTRONIK Germany
Tel: +49 6172 13881-0
info@epluse.de / www.epluse.de

E+E ELEKTRONIK France
Tél: +33 4 7472 3582
info@epluse.fr / www.epluse.fr

E+E ELEKTRONIK Italy
Tel: +39 02 2707 8636
info@epluse.it / www.epluse.it

E+E ELEKTRONIK Korea
Tel: +82 31 732 6050
info@epluse.co.kr / www.epluse.co.kr

E+E ELEKTRONIK USA
Tel: +1 508 530 3068
office@epluse.com / www.epluse.com