

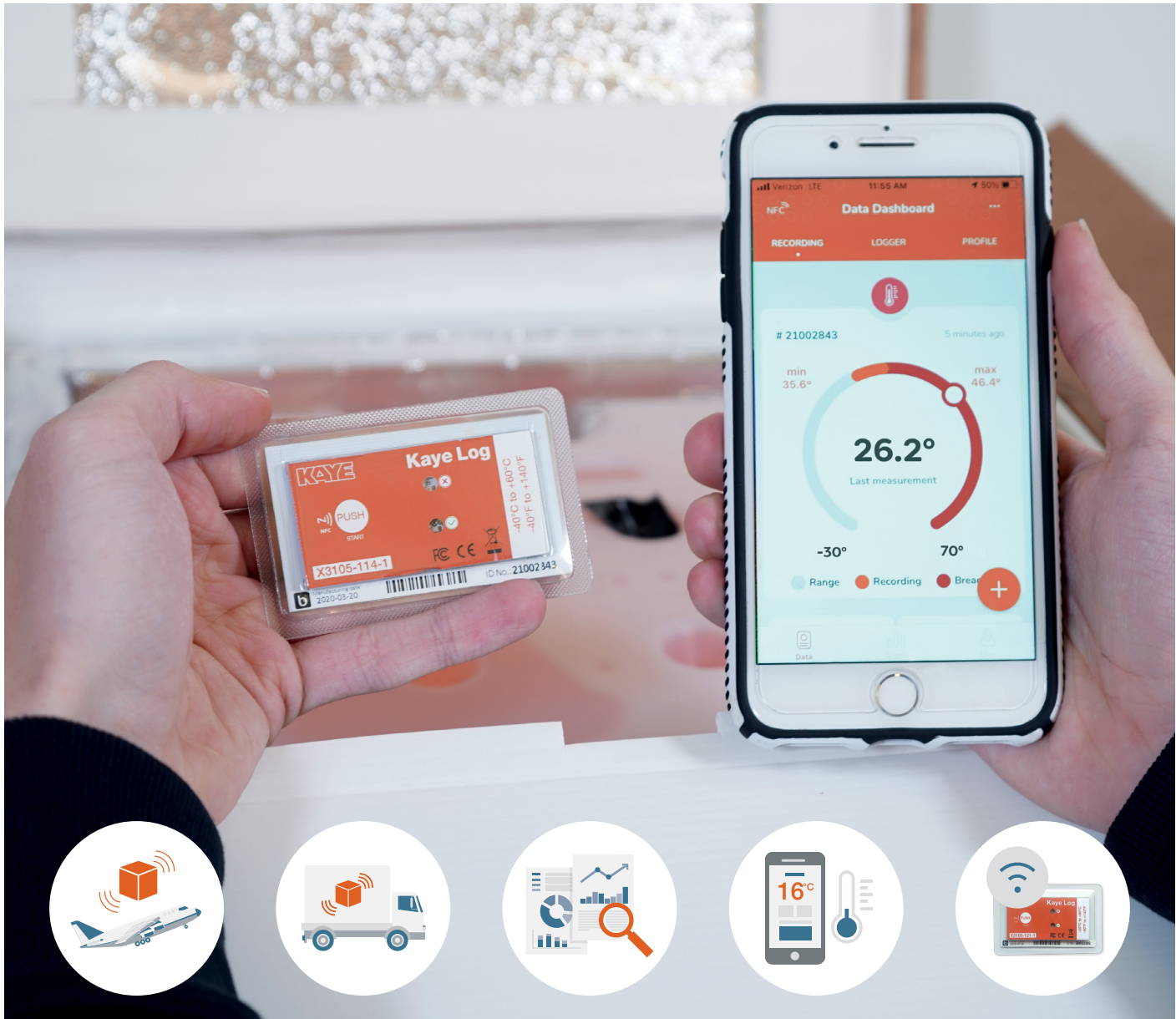

Kaye Log

COLD CHAIN MONITORING DURING TRANSPORT

WIRELESS AND AFFORDABLE TEMPERATURE MONITORING ON A TINY DEVICE



Monitor your Sensitive Product Shipment on your Smartphone

WHAT IS NFC TECHNOLOGY?

NFC – Near Field Communication allows contactless communication between devices like smartphones or other enabled devices. No matter where you are – with just one swipe on your NFC Technology equipped device it is now possible to instantly read, send and receive alerts.

ALL-IN-ONE SOLUTION FOR TRANSPORTING YOUR TEMPERATURE-SENSITIVE PRODUCTS

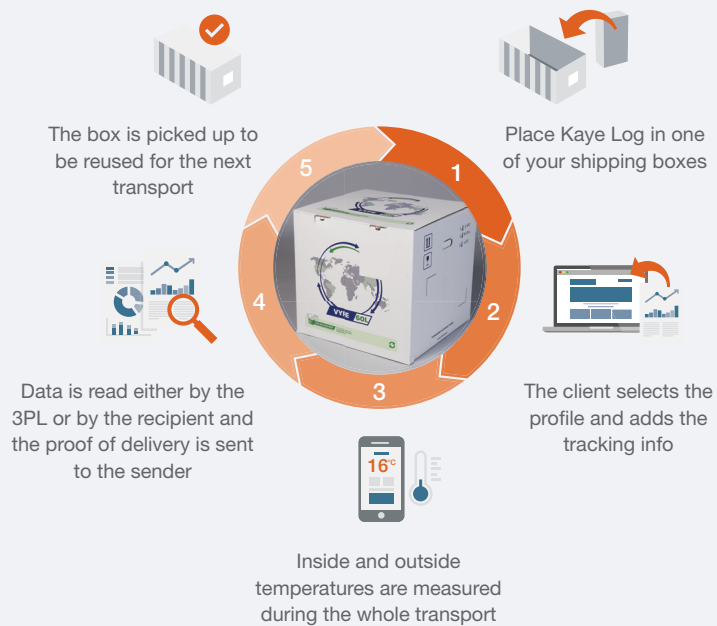

UP TO 90% REDUCTION OF TIME SPENT IN OPERATIONS

NFC

- Fast and secure data transfer with any NFC enabled mobile device.
- Eliminates the need to remove device from shipment.

Accurate and Robust

- Reliable measurement technology, electronic certificates included with each logger.

Alert LEDs

- Instant visual notification if thresholds have been breached.

Logistics Simplified

- Only 2.5mm thick, easily integrates into any packaging.
- Label can be programmed with any shipment and product information.

Cloud Security

- Encrypted data transfer to the secure cloud.
- Access protected by user accounts.

Affordable, Single and Multiuse

- Different versions ranging from 36 days to 1 year of use.

Protecting your Pharma Shipments

The Kaye Log NFC Data Logger enables full temperature traceability during the transport of temperature, or temperature/humidity sensitive products. Upon arrival of the package, a go/no go LED (that can be personalized) indicates immediately if the cold chain has been breached. All temperature/humidity history can be directly accessed from any smartphone equipped with the NFC technology along with GPS and shipping information.



LOADING/PACKAGING

- Loggers, pre-programmed with all the stability info are integrated with products
- Logger's ID is paired with ID of the product/shipment
- Easy integration with serialization, tracking and quality platforms
- Possibility to add logistics and product info



TRANS-SHIPMENT/IMPORT

- Logistic agents can check parameters via NFC without opening the box/pallet
- Current temperature/geolocalisation info is sent to the client, allowing pro-activity



DELIVERY

- PDF report is generated automatically upon reading of data
- All the data is uploaded to the cloud
- The sender gets an automatic proof of delivery

Kaye Log NFC X3105 Series Temperature Data Logger

AVAILABLE AS SINGLE USE (36/100 DAYS) OR REUSABLE (1 YEAR)

FEATURES

- Temperature measurement
- Sensirion® calibrated sensor
- Temperature range: -40°C to +60°C
- Resolution: 0.1°C
- NFC
- Internal battery
- Quick and easy installation
- Maintenance-free
- Resistant to weather conditions
- Resistant to mechanical damage
- IP 67
- Compliant with norms:
 - CE
 - HACCP
 - ETSI 300220
 - FCC

TECHNICAL SPECIFICATIONS - X3105

Temperature unit	°C
Temperature Range	-40°C to 60°C
Accuracy	From 0°C to +30°C typically +/- 0.2°C; +/- 0.5°C for the rest
Validity	part #: X3105-111-1/36 days single use part #: X3105-121-1/100 days single use part #: X3105-114-1/1 year reusable
Intervals	10 minutes default. Modifications start from 1 minute with resolution of 1 second
Memory	5.000 records
IP	67
Power Supply	Internal battery
Dimensions	85mm x 50mm x 5mm
Weight	10g
Necessary equipment	NFC reader, smartphone or tablet with NFC

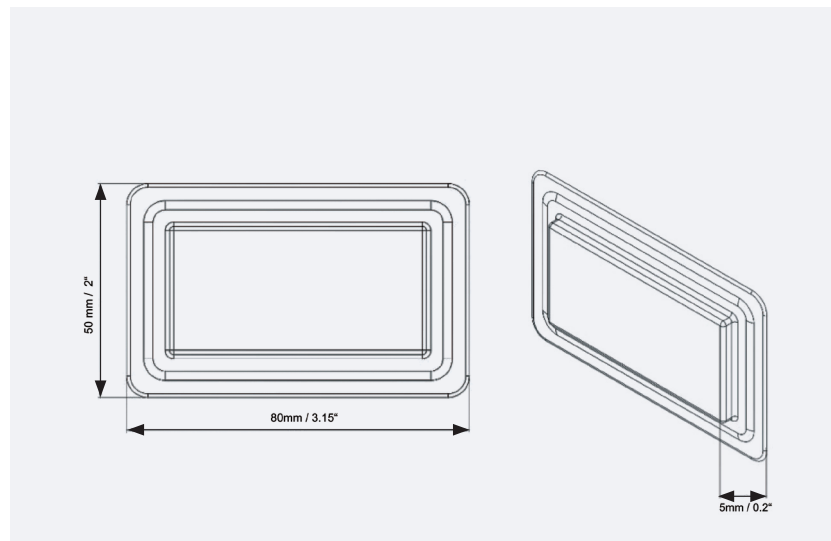

NFC X3106 Temperature Logger with External Probe

LOGGER CHARACTERISTICS

- Temperature measurement
- Sensirion® calibrated sensor
- Sensor attached on external probe
- Probe length and shape can be customized (default 1 meter)
- Temperature range: -40°C to +120°C
- Resolution: 0.1°C
- NFC depending on logger
- Internal battery
- Quick and easy installation
- Maintenance-free
- Resistant to weather conditions
- Resistant to mechanical damage
- IP 44
- Compliant with norms:
 - CE
 - HACCP
 - ETSI 300220
- Logger holder provided

TECHNICAL SPECIFICATIONS - X3106

Temperature unit	°C
Temperature Range	-40°C to 120°C
Accuracy	From 0°C to +30°C typically +/- 0.2°C; +/- 0.5°C for the rest
Validity	part #: X3106-111-1 / 36 days single use part #: X3106-121-1 / 100 days single use part #: X3106-114-1 / 1 year reusable
Resolution	0.1°C
Intervals	10 minutes default. Modifications start from 1 minute with resolution of 1 second
Memory	5.000 samples
IP	44
Power Supply	Internal battery
Dimensions	85mm x 54mm x 5mm
Weight	30g
Necessary equipment	NFC reader, smartphone or tablet with NFC

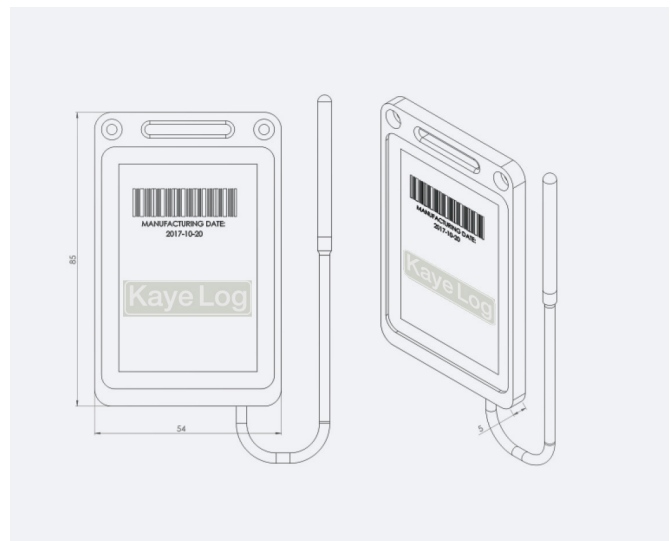

NFC X3110 Temperature and Humidity Data Logger

FEATURES

- Temperature measurement
- Sensirion® calibrated sensor
- Temperature range: -30°C to +70°C
- Humidity range: 0% to 100%
- Resolution: 0.1°C
- NFC
- Internal battery
- Quick and easy installation
- Maintenance-free
- Resistant to weather conditions
- Resistant to mechanical damage
- IP 44
- Compliant with norms:
 - CE
 - HACCP
 - ETSI 300220
- Logger holder provided

TECHNICAL SPECIFICATIONS - X3110

Temperature unit	°C
Temperature Range	-30°C to 70°C
Humidity Range	0% to 100%
Accuracy	From 20% to 80% typically +/- 2%
Validity	part #: X3110-111-1/36 days single use part #: X3110-121-1/100 days single use part #: X3110-114-1/1 year reusable
Resolution	0.1°C
Intervals	10 minutes default. Modifications start from 1 minute with resolution of 1 second
Memory	5.000 records
IP	44
Power Supply	Internal battery
Dimensions	85mm x 54mm x 5mm
Weight	30g
Necessary equipment	NFC reader, smartphone or tablet with NFC

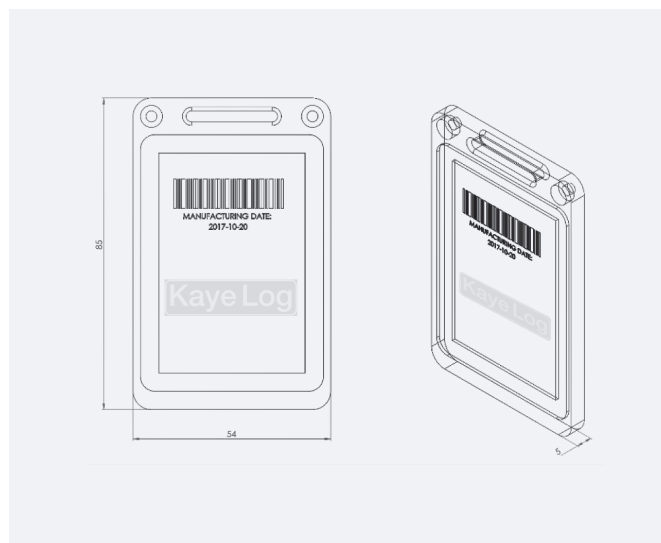

NFC USB Reader

THE NFC USB READER ALLOWS THE USER TO PROGRAM AND READ DATA FROM THE NFC LOGGERS ON A COMPUTER RUNNING WINDOWS.

Kaye NFC allows you to create a profile with your recording settings (min. and max. temperatures, frequency, etc.) and apply this profile to one or more NFC loggers. Simply follow the software instructions – position your loggers on the reader to program them quickly. The NFC USB Reader, combined with Kaye NFC Software saves you time by allowing you to scan an entire pack of loggers at one time and download data from them.



NFC Android Reader

THE FIRST PROFESSIONAL ANDROID-BASED NFC DEVICE DESIGNED TO MEET B2B EXPECTATIONS.

FEATURES

- Android based – as flexible as a smartphone
- Highly mobile – lightweight, pocket-sized and connected
- Managed over the air – centralized and secure OTA device management platform
- Dedicated device – can be dedicated to a single application
- Secure by design – embedded SE/SAM for the highest security



Kaye representative contact:
www.kayeinstruments.com/en/contact

Request a demo:
www.kayeinstruments.com/en/demo

EUROPE, MIDDLE EAST, AFRICA AND ASIA

Amphenol Advanced Sensors Germany GmbH
Sinsheimer Strasse 6
D-75179 Pforzheim
T: +49 (0) 7231-14 335 0
F: +49 (0) 7231-14335 29
Email: kaye@amphenol-sensors.com
www.kayeinstruments.com

USA/AMERICAS

Amphenol Thermometrics, Inc.
967 Windfall Road
St. Marys, PA 15857
T: +1(814) 834-9140
F: +1(814) 781-7969
Email: kaye-us@amphenol-sensors.com
www.kayeinstruments.com

INDIA

Amphenol Interconnect India Pvt Ltd.
Plot no. 6, Survey No.64
Software Units layout
MAHAVEER TECHNO PARK
Hitech City, Madhapur
Hyderabad, Telangana – 500081
T: +91 40 33147100
Email: kaye-india@amphenol-sensors.com
www.kayeinstruments.com

CHINA

Amphenol (Changzhou) Connector Systems Co., Ltd
Building 10, Jintong Industrial Park,
No. 8 Xihu Road, Wujin High-Tech Development Zone,
Changzhou, Jiangsu 213164
T: 0086-519-83055197
www.kayeinstruments.com

