



MicroFlow-i

Instruction Manual



MicroFlow-i (SECOND EDITION REV 1)

April 2021

Part Number M-MFi-S-002-1P

COPYRIGHT

© Pulsar Measurement, 2017 -20. All rights reserved. No part of this publication may be reproduced, transmitted, transcribed, stored in a retrieval system, or translated into any language in any form without the written permission of Pulsar Process Measurement Limited.

WARRANTY AND LIABILITY

Pulsar Measurement guarantee for a period of 2 years from the date of delivery that it will either exchange or repair any part of this product returned to Pulsar Process Measurement Limited if it is found to be defective in material or workmanship, subject to the defect not being due to unfair wear and tear, misuse, modification or alteration, accident, misapplication, or negligence.

DISCLAIMER

Pulsar Measurement neither gives nor implies any process guarantee for this product and shall have no liability in respect of any loss, injury or damage whatsoever arising out of the application or use of any product or circuit described herein.

Every effort has been made to ensure accuracy of this documentation, but Pulsar Measurement cannot be held liable for any errors.

Pulsar Measurement operates a policy of constant development and improvement and reserves the right to amend technical details, as necessary.

The MicroFlow-i shown on the cover of this manual is used for illustrative purposes only and may not be representative of the actual MicroFlow-i supplied.

CONTACT

For technical support, please contact:

Europe: supporteurope@pulsarmeasurement.com

Outside Europe: supportnorthamerica@pulsarmeasurement.com

If you have any comments or suggestions about this product, please contact:

Europe: europa@pulsarmeasurement.com

Outside Europe: northamerica@pulsarmeasurement.com

Pulsar Measurement website: www.pulsarmeasurement.com

United States

11451 Belcher Road South
Largo,
FL 33773
888-473-9546

Canada

16456 Sixsmith Drive
Long Sault, Ont.
K0C 1P0
855-300-9151

United Kingdom

Cardinal Building, Enigma
Commercial Centre
Sandy's Road, Malvern
WR14 1JJ
00 44 (0)1684 891371

CONTENTS

Chapter 1: Start Here... 6
 About this Manual6
 About the MicroFlow-i7
 Benefits.....8
 Functional Description8
 Product Specification.....9
 EU Certificate of Conformity 11
Chapter 2 Installation 12
 Unpacking 12
 Power Supply Requirements..... 12
 Cable Screen and Earth Requirements 12
 Information specific to Hazardous Area Installation..... 13
 Location 18
 Mounting..... 18
 Angled Mounting Bracket..... 19
 MicroFlow-i Sensor.....20
 Terminal Connection Details 25
Chapter 3 Locating The MicroFlow-i.....26
 Preparation for Operation 30
 General Maintenance 30
 Sensor Maintenance. 31
Chapter 4 Understanding How The MicroFlow-i Works 33
 MicroFlow-I HART compatible.....33
 4-20 mA Device 33
Chapter 5 MicroFlow-i PC 34
 Software installation 34
 Connecting to MicroFlow-i HART PC..... 35
 Flow Tab..... 37
 Configuration..... 38
 Parameter Get/Set 38

MicroFlow-i Manual Setting	39
4 – 20mA Trim	40
Trace Tab	41
Comport.....	43
Language.....	43
Tools menu	43
Info.....	44
Exit.....	45
Chapter 6 Parameter Listing and Description	45
Parameter Access.....	45
Device Information Parameters.....	45
Processing Parameters.....	46
MicroFlow-i Firmware Upgrade.....	50
MicroFlow-i HART Firmware Upgrade.....	52
Chapter 7 Troubleshooting.....	54
Chapter 8 Disposal	55
Notes	56

CHAPTER 1: START HERE...

Congratulations on your purchase of a Pulsar MicroFlow-i. This quality system has been developed over many years and represents the latest in high technology flow monitoring.

It has been designed to give you years of trouble-free performance, and a few minutes spent reading this operating manual will ensure that your installation is as simple as possible.

About this Manual

It is important that this manual is referred to for correct installation and operation. There are various parts of the manual that offer additional help or information as shown.

Tips



Look for this icon throughout your Pulsar Measurement manual to find helpful information and answers to frequently asked questions.

Additional Information

Additional Information

At various parts of the manual, you will find sections like this that explain specific things in more detail.

References

— See Also

References to other parts of the manual.

About the MicroFlow-i



The MicroFlow-i is a 2-wire loop-powered non-contacting velocity sensor, with hazardous area approval. The sensor provides reliable flow velocity measurements using short pulses of micro-waves, which are transmitted by an enclosed antenna. When reflected off a moving surface, the signal experiences a shift in frequency characteristics. The reflected signal is captured by the on-board microprocessor via the antenna and analysed to determine the velocity.

The MicroFlow-i's compact and versatile design makes it easy to install and ideal for confined spaces. Housed in a robust enclosure coupled with a fully encapsulated microwave antenna, it provides an effective fit-and-forget flow velocity solution.

Perfect for remote monitoring or when there is no mains power available, due to its low power consumption. To access flow velocity data, use Pulsar's MicroFlow-i HART PC or HART protocol.

Overall, the device has outstanding stability, accuracy and repeatability.

Benefits

Combined with the ease of programming there are many other benefits to using the MicroFlow, these are listed below:

- Non-contact velocity measurement.
- Loop powered and ideal for remote monitoring.
- Low-power consumption.
- Hazardous area approval (Ex ia) for Zone 0.
- 'See through' capability for enclosed plastic pipes and concrete (not reinforced) channels.
- Suitable for abrasive and aggressive materials.
- Resilient to liquid vapour, wind or temperature.
- No minimum liquid level required for measurement
- Maintenance free.
- No interruption to operational flow.
- Can be installed in addition to existing in process contact measuring devices.
- Easily setup using MicroFlow-i HART PC.
- The sensor is capable of monitoring flow of very shallow liquid, mitigating the constraint associated with in-liquid techniques.

Functional Description

Based upon state-of-the-art micro-wave sensing technology, the MicroFlow-i integrates Pulsar's innovative and award-winning DSP (Digital Signal Processing) platform, offering you a cost-effective solution with excellent reliability and performance.

The Pulsar MicroFlow-i has been designed to provide maintenance free performance. The MicroFlow-i is also intrinsically safe (Ex ia) for Zone 0. The MicroFlow-i can be mounted via a rear 1" BSP to M20 thread adapter (supplied with unit). The MicroFlow-i is loop powered and gives a 4 to 20mA output which is proportional to the **flow velocity**. A 'fault condition' alarm will give out a reading of either 3.8mA or 22mA.

The 2-wire sensor can either be used in digital HART mode or as 4-20mA loop powered device. The MicroFlow-i loop powered version can be set up using a HART modem with either proprietary HART software such as Pact ware or Pulsar MicroFlow-i HART PC software.

Boot up time from power up to stable reading: cold boot 8.5 seconds, warm boot 4 seconds (if within 12 hours from last start up).

Product Specification

PHYSICAL

Sensor body material	Valox 357U
Mounting Connection	Via 1" BSP or NPT back mounted thread, 45° Angled mounted bracket (optional) and M20 thread adaptor.
Mounting angle	45° optimum and mounted at the center line of the channel, with clear uninterrupted flow.
Sensor dimensions	Diameter 90mm x height 140mm (3.54" x 5.51")
Weight	0.7kg (1.54 lbs)
Transducer Cable Extensions	2-core screened
Maximum Separation	Up to 1000m (3,280 ft)

ENVIRONMENTAL

Enclosure protection	IP68
Max & min temperature (electronics)	-20° to +60°C (-4°F to +140°F)

APPROVALS

CE and Radar Approval	See EU Declaration of Conformity CML 16ATEX2331X, IECEx CML 16.0105X
ATEX Approval	II 1 G Ex ia IIC T4 Ga II 1 D Ex ia IIIC T135°C Da

PERFORMANCE

Velocity Range	0.2 – 6 m/s (0.66 ft/s – 19.7 ft/s)
Accuracy	Greater of +/- 0.5% or 0.05 m/s (0.1 ft/s)
Optimum Installation	Install at an angle of 45° in line with flow. For more information, see 'Locating the MicroFlow-i sensor' section of this manual.
Max. channel width per sensor	1.5m
Radar	K-Band (ISM)
Transmit Power	<15 dBm
Beam width	20° inclusive

OUTPUTS

Communication	HART compatible, 4-20mA loop powered.
----------------------	---------------------------------------

PROGRAMMING

PC programming	Via RS232
Programmed data integrity	Via non-volatile RAM, plus backup
PC Setup and monitoring Software	MicroFlow PC – compatible with Win 7 (latest service pack), Win 8, Win 10

SUPPLY

Operating voltage

10 – 28 VDC

Power Consumption

Start-up = 20mA. Average current = 60 μ A per hour when one velocity measurement is performed every 15 minutes

Pulsar Measurement operates a policy of constant development and improvement and reserve the right to amend technical details, as necessary.

EU Certificate of Conformity



EU DECLARATION OF CONFORMITY

PULSAR *MicroFlow* & *MicroFlow-I*

This declaration of conformity is issued under the sole responsibility of the manufacturer

Relevant directive(s)	2014/30/EU - EMC directive and its amending directives. 2014/53/EU - Radio equipment directive and its amending directives. 2014/35/EU - Low Voltage directive and its amending directives. 2014/34/EU - ATEX directive and its amending directives. 2011/65/EU - RoHS directive and its amending directives.
Manufacturer's name	Pulsar Process Measurement Ltd.
Manufacturer's address	Cardinal Building, Enigma Commercial Centre, Sandy's Road, Malvern, Worcestershire, WR14 1JJ, UK.
Apparatus	DC powered microwave sensor.
Models	Pulsar MicroFlow, RS485 version & MicroFlow-I, loop powered version.
Type of equipment	Measurement and process control.
Standards applied	EN 61010-1:2010+A1:2019 Safety requirements for electrical equipment for measurement, control and laboratory use. EN 62311:2008 Assessment of electronic and electrical equipment related to human exposure restrictions for electromagnetic fields (0 Hz – 300 GHz). EN 300 440-1: V1.6.1, EN 300 440-2: V1.4.1 EMC and radio spectrum matters; short range devices; radio equipment used in the 1 GHz to 40 GHz frequency range. EN 61326-1:2013 EMC, equipment class industrial. EN 60079-0:2012+A11:2013 ATEX general requirements. EN 60079-11:2012 ATEX intrinsic safety (Ex ia). EN 60079-18:2015+A1:2017 ATEX encapsulation (Ex mb).
Notified body	CML B.V., # 2776.
Role	Issue of ATEX / IECEx EU type examination certificates.
Auditing body	CSA Group Netherlands B.V., #2813.

I declare that the apparatus named above has been tested and complies with the relevant sections of the above referenced standards & directives.

Signed for and on behalf of:

A handwritten signature in black ink, appearing to read "Tim Brown".

Date: 6th April 2021.

Rev. 2.2 .

Name & function: Tim Brown, electronics engineer.

Pulsar Process Measurement Ltd.

CHAPTER 2 INSTALLATION

Unpacking

Important Information

All shipping cartons should be opened carefully. When using a box cutter, do not plunge the blade deeply into the box, as it could potentially cut or scratch equipment components. Carefully remove equipment from each carton, checking it against the packing list before discarding any packing material. If there is any shortage or obvious shipping damage to the equipment, report it immediately to Pulsar Process Measurement Limited.

Power Supply Requirements

The MicroFlow-i can operate from a DC supply of 10 to 28V. In all cases the unit typically consumes 0.52W of power, and will typically draw less than 22mA.

Cable Screen and Earth Requirements

The MicroFlow-i comes with a fitted integral cable, if this cable is extended then the total capacitance must not exceed the limits for the voltage applied, and the hazardous area it is installed in.

The HART modem and PC or HART programmer are used to set up the operation parameters for the MicroFlow-i sensor. The output can either be as a 4-20mA current giving flow velocity or as a digital signal via a HART master.

The MicroFlow-i cable is a twisted pair with an overall cable screen. The twisted pair are red and black, connect the red to +ve and the black to the -ve. The screen should go to signal ground.

Important Information

If the equipment is installed or used in a manner not specified in this manual, then the protection provided by the equipment may be impaired

Information specific to Hazardous Area Installation

(Reference European ATEX Directive 2014/34/EU)

The following instructions apply to equipment covered by certificate number CML 16ATEX2331X

1. The equipment may be used with flammable gases and vapours with apparatus groups IIC, IIB, and IIA with temperature classes; T4 ambient temperature range -20°C to +60°C.
2. The equipment is only certified for use in ambient temperatures in the range -20°C to +60°C and should not be used outside this range.
3. Installation shall be carried out in accordance with the applicable code of practise by suitably trained personnel.
4. Repair of the equipment shall be carried out in accordance with the acceptable code of practise.
5. Certification as detailed in drawing number D-804-1200 (Ex ia).
6. If the equipment is likely to encounter aggressive substances, then it is the responsibility of the user to take suitable precautions that prevent it from being adversely affected, thus ensuring that the type of protection is not compromised.

Aggressive Substances: e.g., such as acidic liquids or gases that may attack metals or solvents that may affect polymeric materials.

Suitable precautions: e.g., regular checks as part of routine inspections or establishing from the materials data sheet that it is resistant to specific chemicals.

7. The certificate number has an 'X' suffix that indicates that the following special condition of certification applies. In the case of the MicroFlow-i sensor, due to the housing and labels being non-conductive plastic care needs to be taken with regards to electrostatic charge. The equipment shall not be installed if the conditions are conducive to the build-up of electrostatic charge. Additionally, the equipment should only be cleaned with a damp cloth.

Limitations on use

1. The MicroFlow-i must be routinely inspected to avoid the build-up of dust layers when installed in Zone 21 & Zone 22.
2. Electrostatic hazard – The MicroFlow-i must only be wiped with a damp or antistatic cloth.
3. The outer enclosure is made from Valox357U, consider the performance of this material with respect to chemicals that may be present in the hazardous area.

Hazardous Area Specific Power Supply and barrier Requirements

The MicroFlow-i operates from a DC supply of 10 – 28VDC and will typically draw less than 22mA.

When connecting the sensor to the PC software with a HART modem, it is recommended to use a supply of at least 18VDC.

Important Information

In the case of the Ex ia version, the sensor must be powered from an approved I.S. safety barrier or approved I.S. power supply with the following limits:

$U_o \leq 28V$, $I_o \leq 162mA$, $P_o \leq 1.03W$

The MicroFlow-i cable is a twisted pair with overall cable screen. The twisted pair is red and black, connect the red to +ve and the black to -ve. The screen should go to signal ground.

Typical wiring for the MicroFlow-i:

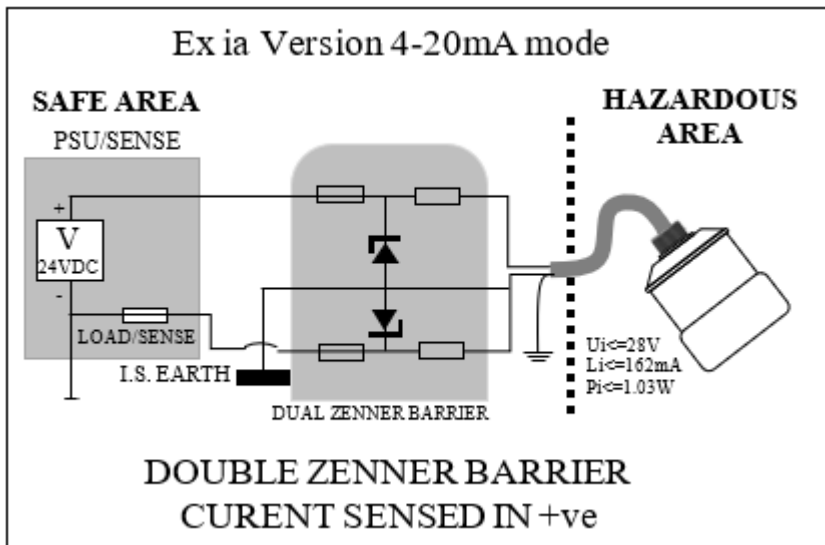
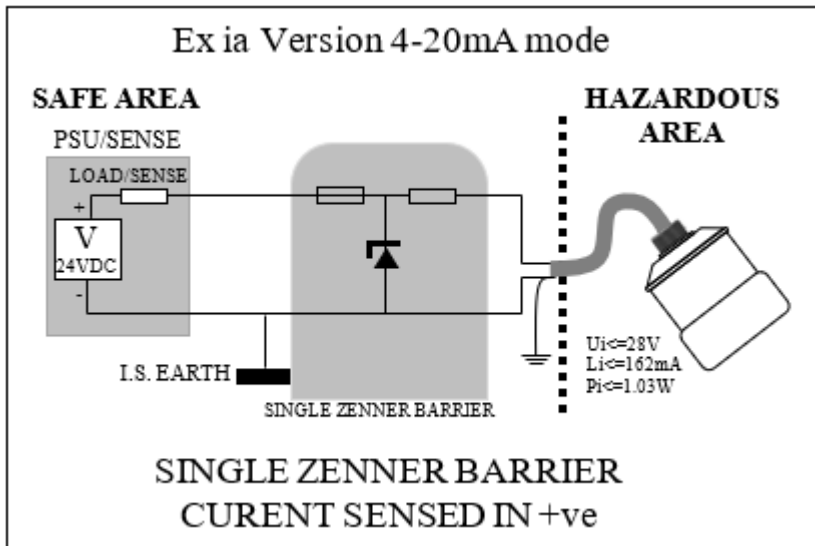

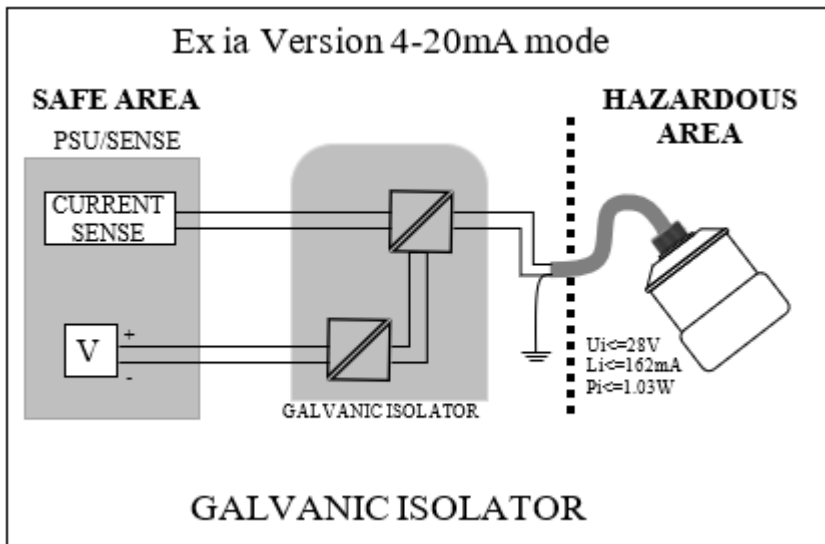

Important Information

If the equipment is installed or used in a manner not specified in this manual, then the protection provided by the equipment may be impaired.

Loop Resistance

For two wire operation, the maximum cable resistance allowable can be calculated from the graph below. For example, if an dBi Series Intelligent Transducer was supplied from 24V, the maximum total cable resistance is 600 ohms, for a typical 77 ohm /km cable this would mean a maximum cable length of $600/77 = 7.8\text{km}$, remember this total cable resistance, so this figure must be divided by 2 to give 3.9km max distance.

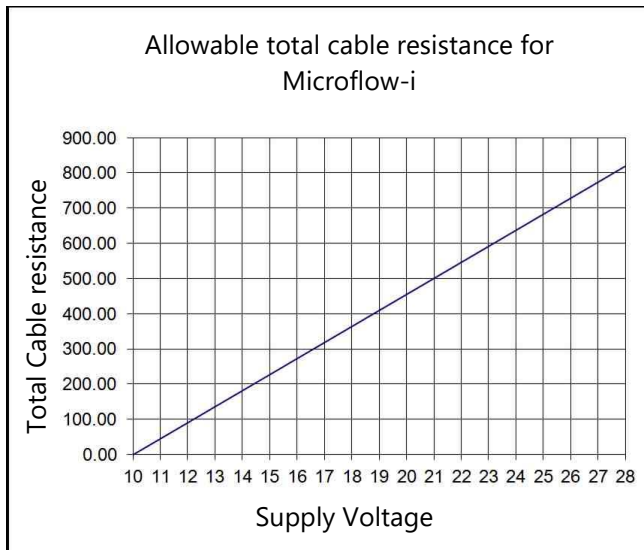

Location

Important Information

All electronic products are susceptible to electrostatic shock, so follow proper grounding procedures during installation.

When choosing a location to mount the bracket and MicroFlow, note the following:

- For optimum readings, it is recommended that the MicroFlow should be positioned at a 45° angle to the surface of the material being measured.
- The mounting surface must be vibration-free.
- The ambient temperature should be between -20°C and 60°C.

Mounting

For the best results it is highly recommended to use the MicroFlow-i angled bracket, which is available from your Pulsar distributor, which will ensure that the MicroFlow-i can be correctly installed. The bracket can be used if the MicroFlow-i sensor is to be mounted on its own in a specific location or along with a Pulsar dBi or dB level transducer. Please see '**Angled Mounting Bracket**' for dimensions of this bracket, please note that the drawing is not to scale.

'**Mounting sensor to a bracket**' illustrates how you would install the sensor to one of Pulsar's angled brackets.

The MicroFlow-i angled bracket should be mounted by marking and drilling the holes suitable for fixing your screws/bolts (length to suit your application) and then fixing the bracket in place.

Angled Mounting Bracket

Part number: dBA0008MF

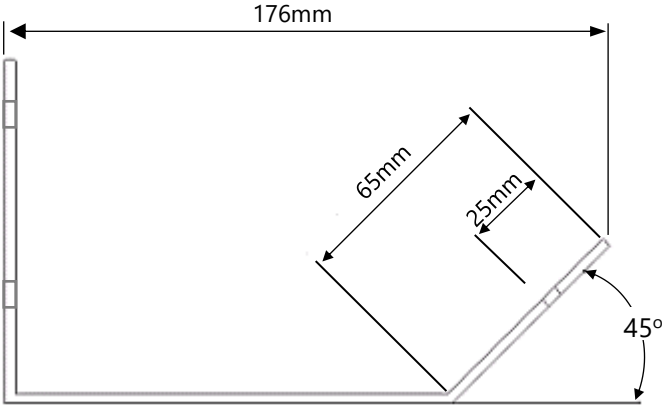

Side view

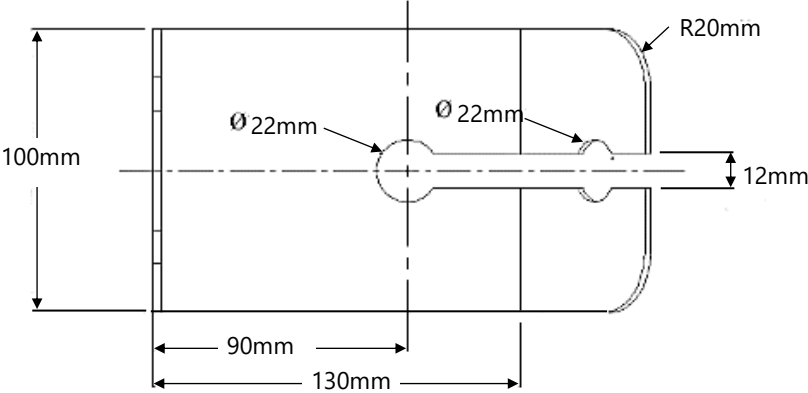

Top view

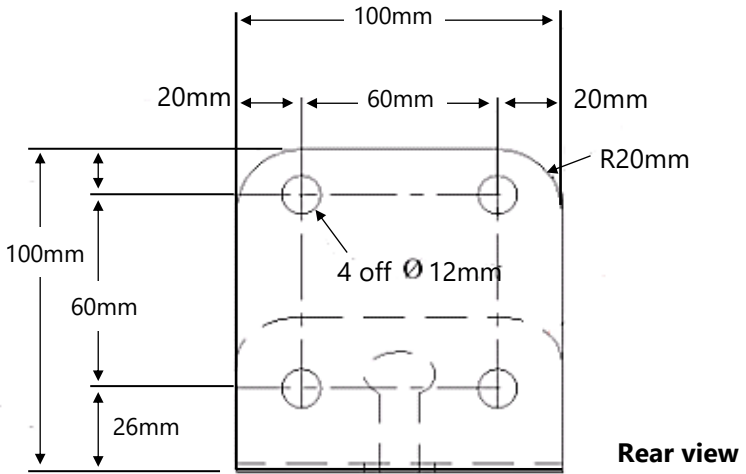

Important Information

Using a spirit level, ensure that the Mounting Bracket is level **before** attaching the sensor to the bracket.

MicroFlow-i Sensor

The dimensions of the sensor body are shown below in Fig.1 and Fig.2:

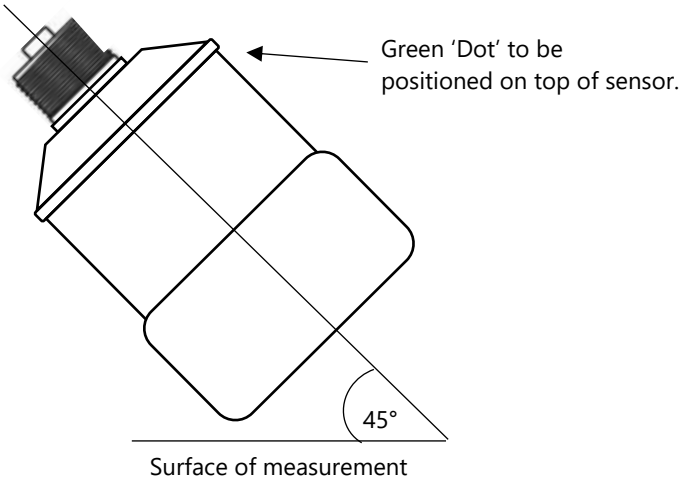
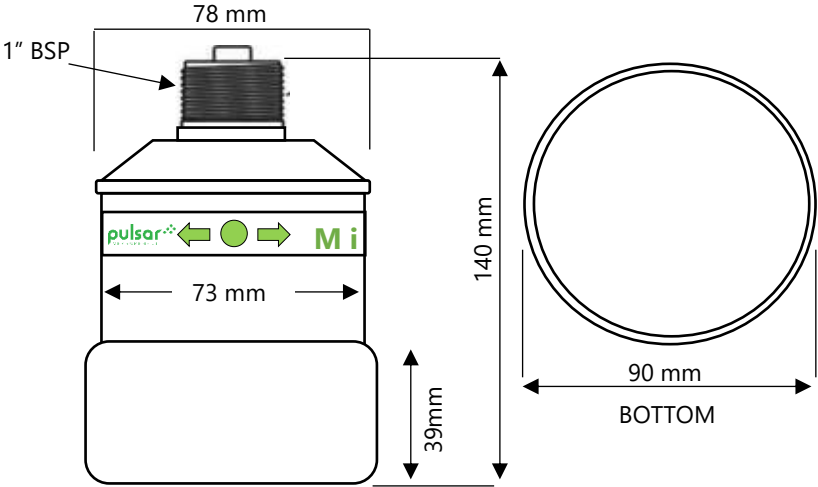

DON'T FORGET

To obtain the most accurate results, ensure the device is mounted at a 45° angle to the surface being measured.

Mounting sensor to a bracket

Mounting the sensor to the 45° angled bracket is done via an adapter and M20 nut, as shown in Fig.3:

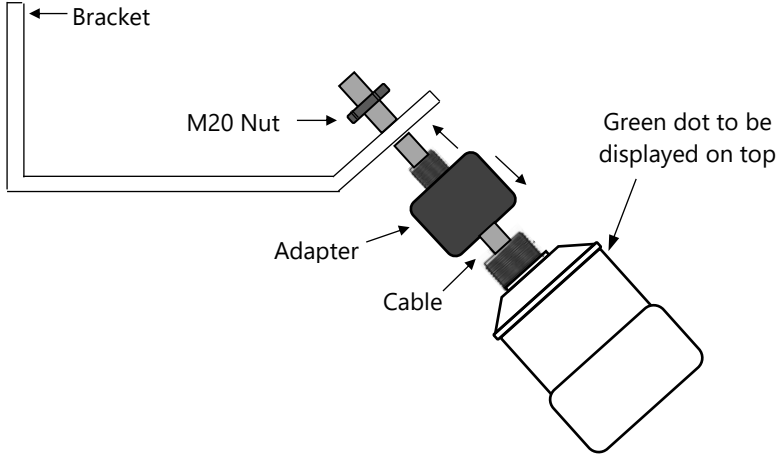

Fig.3

For correct installation, we recommend that the adapter is threaded on the cable, and carefully screwed onto the MicroFlow-i before fitting to the bracket. This will reduce the risk of any 'twisting' in the cable.

Ensure that the sensor is tightened, and the dot is in the correct position.

Important Information

When fixing the sensor to the adapter, ensure that care is taken when pulling the sensor cable through. And once attached to the adapter, and the M20 nut is tightened, the green dot should be central to the movement of flow as shown in Fig.4.

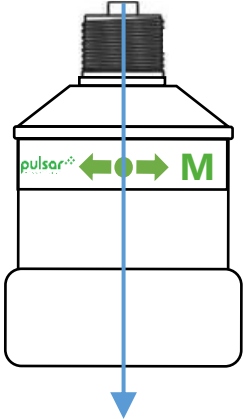

Fig.4

Central to the movement of flow in channel.

Care should be taken not to overtighten the sensor when everything is connected, as seen in Fig.5 below, as this could cause damage to the housing.

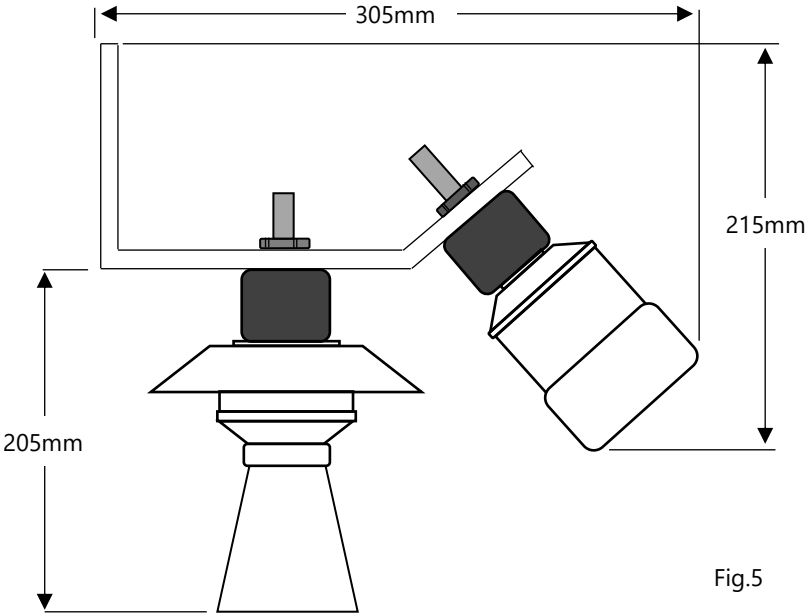

Fig.5

When the sensor is mounted on the bracket with dB series level transducer, you can position the bracket in a way where the MicroFlow-i is obtaining measurements following the direction of the flow, or facing the direction of flow. Fig.6 and Fig.7 illustrate the correct positioning of the devices according to the direction of flow:

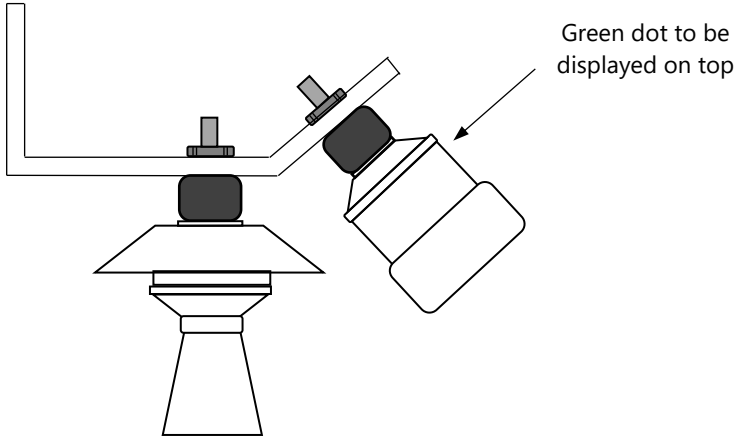

Fig.6

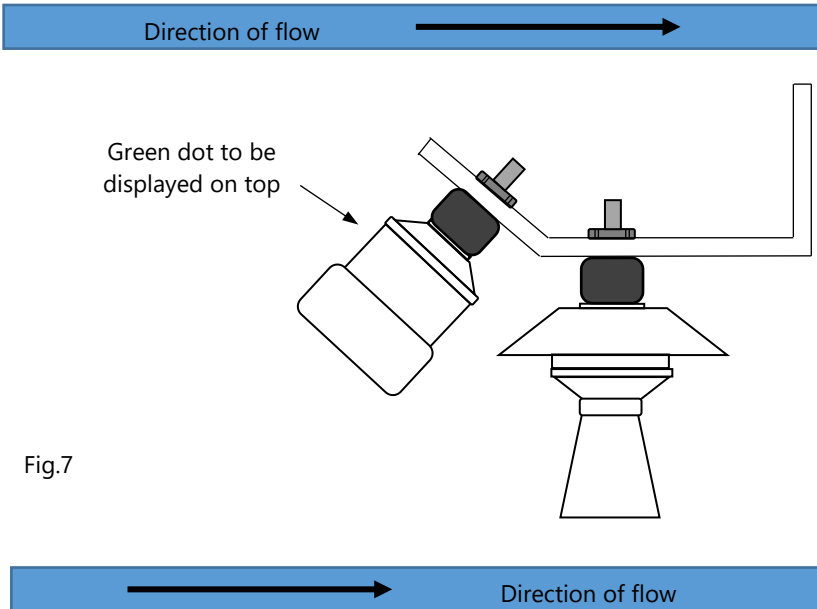
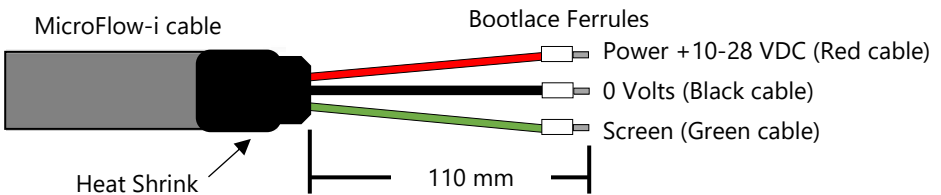

Fig.7

Terminal Connection Details

Power

The MicroFlow-i operates from a DC voltage supply of 10-28 volts, and should be installed and connected in accordance with '[Chapter 2-Power supply requirements](#)' and the instructions below. When wiring the MicroFlow-i the cable used is of a multicore design. The wire coding is shown below for ease of use when connecting the MicroFlow-i to monitor flow velocity:



You can also use Pulsar's MicroFlow-i HART PC software to interrogate and obtain readings from the device. Please refer to **Chapter 6 MicroFlow-i HART PC** for more details on how to use it.

Important Information

If the equipment is installed or used in a manner not specified in this manual, then the protection provided by the equipment may be impaired.

CHAPTER 3 LOCATING THE MICROFLOW-I

For optimum accuracy install the MicroFlow-i where the flow is not turbulent. An ideal location for the sensor is in the centre of a long straight channel. Vertical drops, baffles, curves, or junctions can cause the velocity profile to be distorted.

To obtain optimum results in readings, the MicroFlow-i sensor requires surface ripples to be present to provide a reliable measurement. If there are not any surface ripples within the sensors field of view under ant flow conditions, then an alternative measurement point should be found, or ripples created.

Locating the MicroFlow-i

- If the width of the channel exceeds 1.5m. Multiple MicroFlow-i sensors are required to be used in conjunction with the Ultimate Controller with firmware version 1.5.2 and later.
- When a level measurement transducer is used and mounted on the same bracket as the MicroFlow-i. Consider the 'blanking' distance of the transducer when mounting the bracket for the application.
- Ensure that there is an unobstructed path between the sensor and the surface of the moving liquid being measured.
- Position the sensor at a height of 250mm above maximum liquid level or up to two times the channel width from the minimum liquid level, whichever is greater. As shown in Fig.8 below:

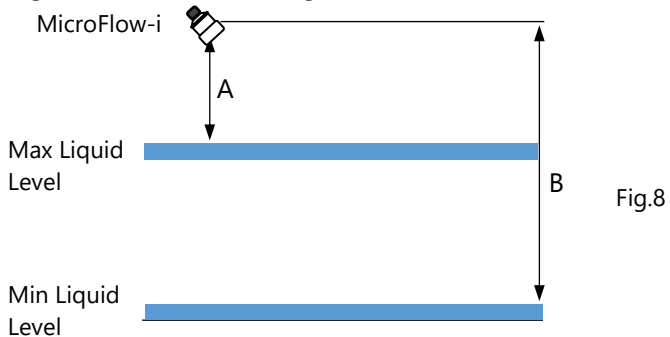

- A = Minimum 250mm above Maximum Liquid level.
- B = Maximum 3m above Minimum Liquid Level.

Important Information

If the maximum water height exceeds 2x width of the channel, OR
If the maximum water height in channel is less than 50% of the width of the channel. Please consult Pulsar product support for assistance.

In the instance where there are vertical drops, baffles, curves or junctions. The sensor should then be positioned on a straight part of the channel, at a minimum distance that is at least five times the width of the channel before a bend, to obtain optimal velocity readings.

Examples of positioning the sensor are shown in diagrams 1 - 4 below:

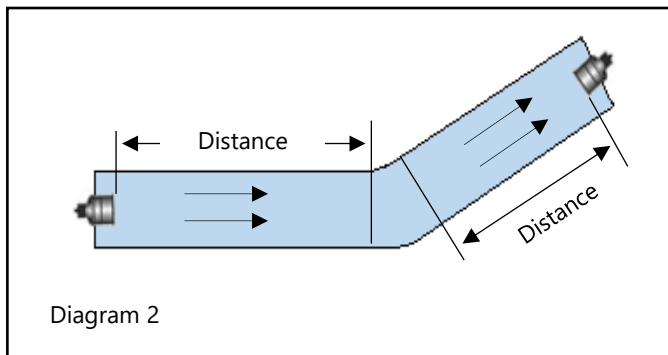
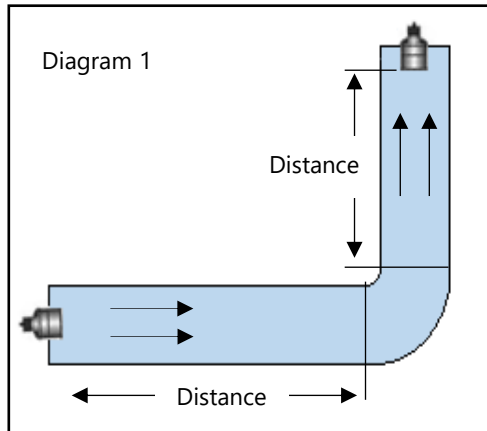

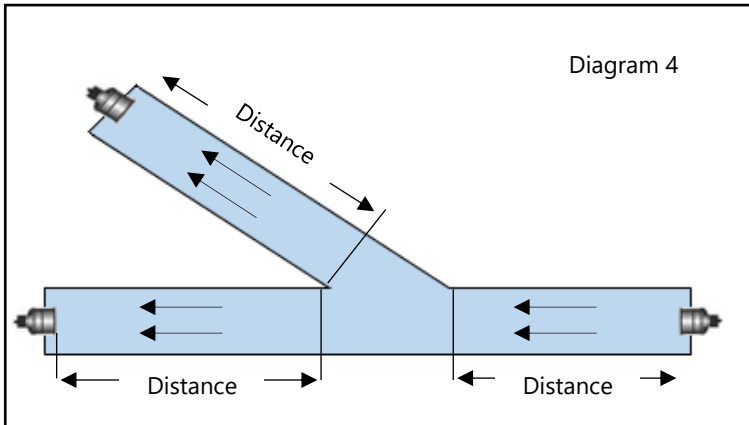
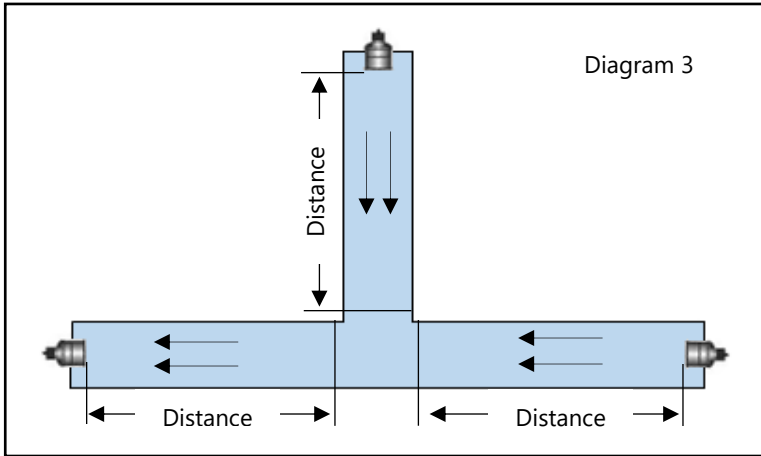

Installing the Sensor

- The Sensor housing is designed to accept a 1-inch BSP female threaded coupler for pipe or conduit.
- Ensure that the sensor is positioned at a 45° angle to the surface of the measured application, as this will achieve the best results. An example of this is shown in the diagram below:

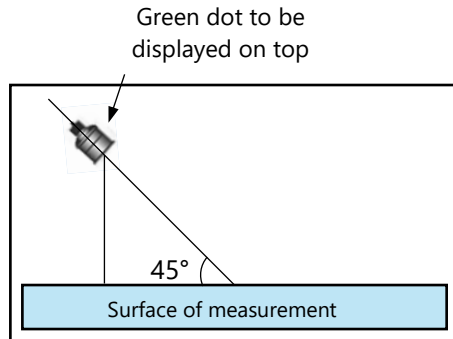

- When using one of the Pulsar Angled Mounting Brackets, secure the bracket using the correct size screws/bolts/U-bolts (12mm diameter thread).
- Tighten the sensor into the bend, and then screw the thread adapter onto the bracket using the nut supplied. **CAUTION: extreme over-tightening may crack or cause damage to the unit or bracket.**
- Position the sensor so the green 'dot' that is shown on the label between the two green arrows is on the top of the device, and is central to the movement of flow in the channel.
- If desired, the sensor cable may be extended up to a maximum of 100m. Install the sensor cables in grounded metal conduit. Do not run-in cable trays or duct banks with variable frequency drives or other high voltage sources.
- When extending cable for a MicroFlow-i sensor, ensure that all wiring in any junction /connector boxes are correct
- When connecting multiple MicroFlow-i sensors for use with the Ultimate controller. Ensure that all wiring in any junction /connector box is correct.

- The sensor can be positioned to obtain readings following the direction of the flow. Or it can be positioned to measure the oncoming flow as seen below:

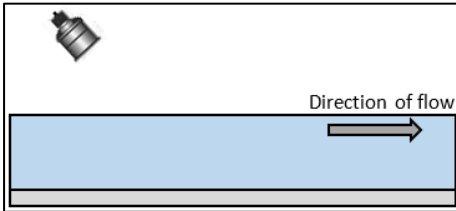

MicroFlow-i obtaining readings following the direction of the flow.

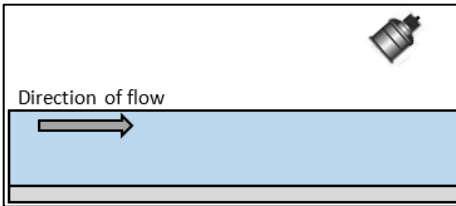

MicroFlow-i obtaining readings from the oncoming direction of the flow.

Preparation for Operation

Before switching on, ensure that the following is checked:

- ✓ MicroFlow-i is mounted correctly and is secure.
- ✓ All wiring is correct to a Pulsar controller.
- ✓ The power supply is correctly installed.

General Maintenance

There are no user serviceable parts inside MicroFlow-i. If you experience any problems with the unit, then please contact Pulsar Process Measurement for advice.

To clean the equipment, wipe with a damp cloth. Do not use any solvents on the enclosure.

Sensor Maintenance.

Procedure for the Removal of a MicroFlow-i Sensor

From time to time, it may be necessary to remove the sensor for cleaning or maintenance purposes, the below procedure is to ensure that this is done carefully with regard for the health and safety of the operator involved, and without damage to the sensor.

Important Information

Before attempting to remove the sensor for cleaning or any other purpose, the power to the unit should be disconnected.

If it is necessary to replace the sensor for any reason, the following procedure should be followed:

- Disconnect the power supply to the sensor.
- Remove any fittings that the sensor may be attached to, allowing the cable to be pulled through with ease.
- If using a Pulsar angled bracket, the sensor head is mounted onto the end of the bend via its process fitting, this should be carefully unscrewed in an anticlockwise direction. Ensure that the sensor is not dropped or knocked as this can cause damage to the unit.
- When replacing the sensor, care must be taken not to over tighten the unit as this can cause damage. Hand tight is sufficient.
- Ensure that the green dot has been positioned in the direction of the flow of the vessel, this will obtain optimum velocity readings that are available. Please refer to '**Fig.3**' in '**Chapter 2-Installing the sensor**' section on how to do this.
- When the sensor has been replaced for the application, and re-connected to a controller and the power re-applied, the unit will re-initialise and will begin the process of acquiring flow and velocity readings.
- When refitting or replacing a sensor, ensure that it is installed in accordance with '**Chapter 2-Mounting a sensor to a bracket**'.
- When replacing the sensor for a new one, you can use MicroFlow-i HART PC to upload any changed parameters from your old sensor to the new sensor. Allowing continued use of the sensor which is setup

for your application. MicroFlow protocol. Allowing you to continue use without the need to change any parameters.

The correct PPE should be worn on site when performing maintenance on the system, if in doubt please contact your site Health and Safety Officer for further advice.

Important Information

Care should be taken when removing and cleaning to not damage the device.

To remove the sensor, first loosen any glands, couplers etc. that may connect it to the Mounting Bracket, and then lift the sensor body onto a safe place. Taking care not to damage the sensor housing or cable whilst performing this removal.

The sensor can then be safely inspected for damage or material fouling and can be carefully cleaned with a damp cloth to remove any foreign debris.

CHAPTER 4 UNDERSTANDING HOW THE MICROFLOW-I WORKS

To initially set up the MicroFlow-i (if required) to obtain readings from your application, it is advised to do this using MicroFlow-i HART PC.

Once the MicroFlow-i has been powered up, you can now begin to obtain flow velocity from the sensor.

MicroFlow-I HART compatible

The MicroFlow-i uses a unique protocol which enables it to be compatible to any HART controller that it is connected to, the HART address is '0'.



To enable the MicroFlow-I to work successfully, ensure that the power is disconnected prior to a connection being made

4-20 mA Device

The MicroFlow-i can be used as an 'out of the box' 4 – 20mA device, this is the case, by default when you switch the sensor on. The 4 – 20mA output is proportional to the flow **velocity** being seen, with respect to the maximum range of the sensor up to 6 m/s (19.7 ft/s).

Important Information

Care should be taken when removing and cleaning to not damage the device.

CHAPTER 5 MICROFLOW-I PC

The software that accompanies the MicroFlow-i can be used to access and change all parameters via the HART modem, test, obtain and record trace readings from a sensor. To utilise the features of the software, a USB HART modem which is available from Pulsar (as shown in Fig.9 below), is required to communicate between the sensor and your machine.



Software installation

Insert the CD that accompanies the MicroFlow-i sensor into your PC/Laptop. If you do not have a CD drive on your laptop, then this software can be downloaded from the Pulsar Process Measurement website:

<https://pulsarmeasurement.com/downloads/software/> and choose to download MicroFlow-i HART PC from the list which will then be downloaded onto your machine.

When setting up the HART modem for the first use, you will need to install the necessary drivers for it to operate correctly with your OS. These drivers can be installed from your installation disc. Run the MicroFlow-i HART PC Setup.exe from the CD, or from the downloaded file from our website to install the MicroFlow-i HART PC software correctly, which will automatically install the necessary drivers for your HART modem. A shortcut icon will be created onto your Desktop for ease of use. Double click on this icon to launch the program.

Important Information

For optimum installation insert your HART modem to your PC whilst installing MicroFlow-i HART PC, where your PC should then assign the modem to a Com Port. Or if you have an internet connection, upon inserting the USB of the HART modem for the first time, Windows updates should install this onto your computer for you. Once the driver's installation has completed, remove the HART modem from your machine. Your modem is ready to be used when a connection to MicroFlow-i PC is required.

Connecting to MicroFlow-i HART PC

When connecting to the software using the HART modem, power to the sensor can be obtained from a 10-28VDC source.

Important Information

Ensure that power to the sensor is switched 'OFF' before removing cables and any connection is made.

To enable the MicroFlow-i to work correctly please ensure that the sensor is wired as shown in the picture below:

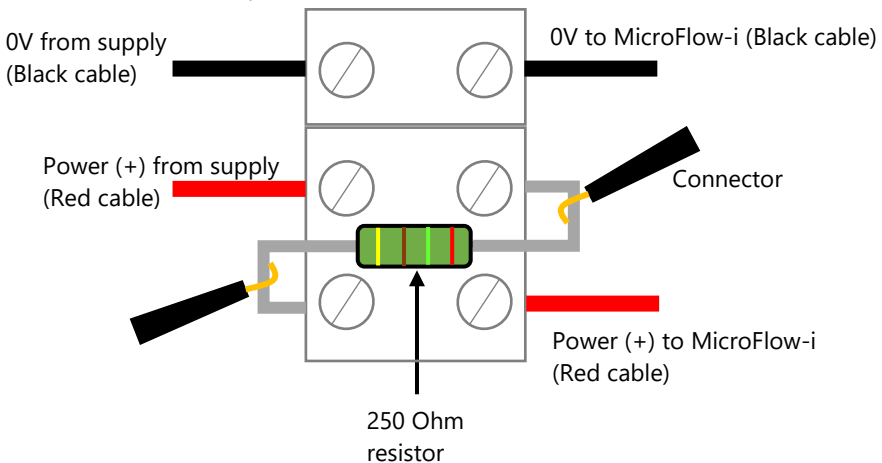

To enable the sensor to work correctly, the power (red) cables from the supply and to the MicroFlow-i must be wired in series with the 250 Ohm resistor (as seen in the above picture).

Once the sensor is connected to the HART modem, insert the USB into the PC/laptop ready for use. You can now use MicroFlow-i HART PC to change settings of the sensor to suit your application.

To make a connection to the MicroFlow-i sensor, supply power to the sensor and then select the button which will change to 'Scanning' and the following pop-up windows will appear during an initial connection:

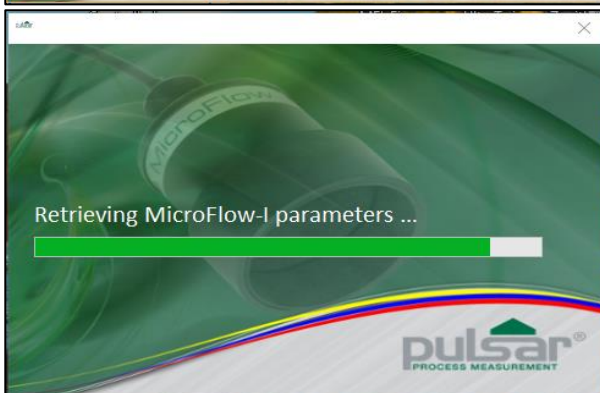
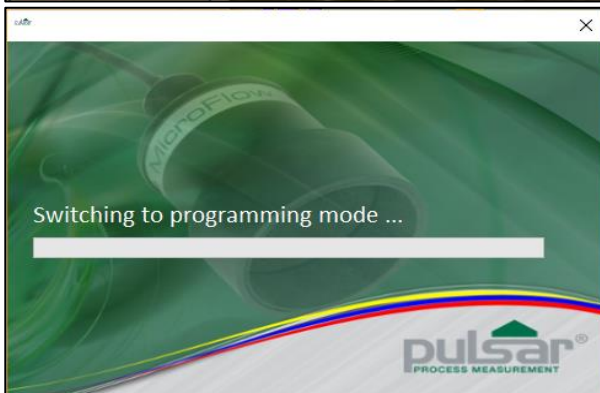

Once the MicroFlow-i parameters have been retrieved successfully, the status condition will then appear as:

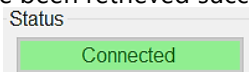

If the sensor fails to connect to the software, please check that the Comport has been correctly set (details of how to do this is outlined in this chapter). After launching the program and connecting to the MicroFlow-i, the device's parameters will be automatically extracted once a connection is established. Once connected you can now view the information received from the sensor on the Software's individual tabs: **Flow**, **Configuration** and **Trace**.

Disconnect appears after a connection is established, selecting this will then disconnect the MicroFlow-i.

Flow Tab

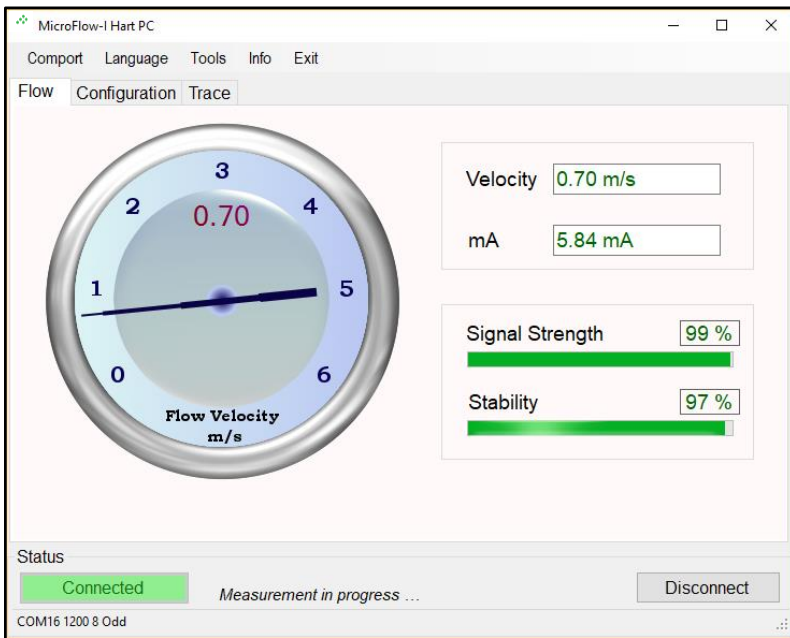

The above picture is an example of the default screen of MicroFlow-i HART PC, which is the Flow tab. The dial on the left displays the linear flow velocity of a maximum up to 6m/s (19.7 ft/s). While the numerical display on the right shows the velocity flow rate and the current mA reading.

Signal Strength

The signal strength gives an indication of the actual strength of the velocity signal detected. A level of higher than 70% is desired for reliable operation.

Stability

The stability level is an indication of the consistency of flow reading, as derived from the combination of signal strength and statistical fluctuations of the flow reading. A high level of stability would indicate optimum condition, and relatively healthy flow within the channel and indicate higher levels of repeatability and better flow tracking. The stability does not necessarily indicate the accuracy of the flow reading, as this is subject to calibration.

Configuration

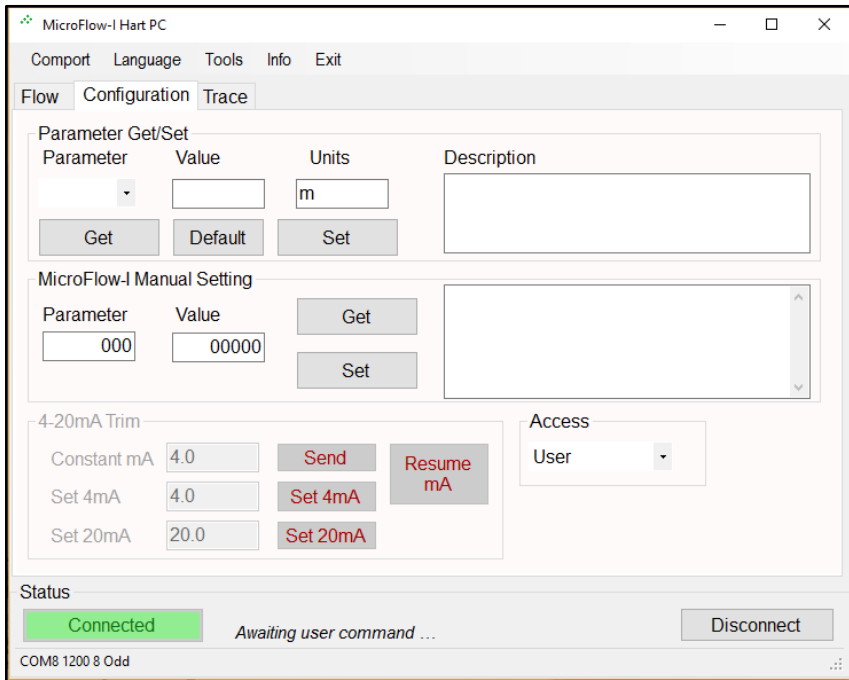

Parameter Get/Set

This feature allows you to obtain and change parameter values from the list available. Further information of these parameters and their values can be found in **Chapter 7 – Parameter Listing and Descriptions**.

Default:

When selected, this will display the current parameters default value. Selecting 'Set' will change the parameters value to that of its default value.

Set:

Allows the value of the selected parameter to be changed. Select the desired parameter from the drop down 'Parameter' box, enter the required value and select 'Set'. The value box will turn green when the change of parameter value has been successfully carried out.

MicroFlow-i Manual Setting

The option for manually setting the parameters can be done by utilising the Manual Setting terminal, as shown below:

This feature is also available when the sensor has been set into 'Program mode', where all if the MicroFlow-i parameters can be queried by entering the parameter address in the Parameter field and then clicking on the 'Get' button. The MicroFlow-i will then reply with the current value of that parameter.

Selecting 'Get' will read and display the current value of the MicroFlow-i parameter selected. When 'selected, within the terminal box you will see a command appear, example `<</p102` as the software queries the chosen parameter. The unit will reply with the parameter and its current value, example: `==/p102:120`

Selecting 'Set' allows the value of the selected MicroFlow-i parameter to be changed, both the address and value must be entered before clicking on the button. `<</p102:100` will show the parameter number and the value you have changed in the manual setting box. And `==/p102:140` will appear when the change of the parameter and its value is complete. The appropriate access levels are required for setting parameters.

The values need to be valid and within the allowed range for that parameter for the change to be successful. Please refer to '**Chapter 7 Parameter listing and Descriptions**' in this manual, on the parameters available and the range each one can be set between. If a parameter has been incorrectly set, choose the parameter from the options in 'Parameter Get/Set' and select the default button to display the default value for that parameter. Pressing set will revert the parameter to its default value.

4 – 20mA Trim

This feature is only available to use when the sensor has been set to 'Run mode', the options will then no longer be greyed out and will now be available to use.

4-20mA Trim			
Constant mA	<input type="text" value="4.0"/>	<input type="button" value="Send"/>	<input type="button" value="Resume mA"/>
Set 4mA	<input type="text" value="4.0"/>	<input type="button" value="Set 4mA"/>	
Set 20mA	<input type="text" value="20.0"/>	<input type="button" value="Set 20mA"/>	

If the device connected to the mA output is out of calibration, and is unable to be calibrated. Then the low and high current levels can be calibrated by altering '**Set 4mA**' (Low Trim) and '**Set 20mA**' (High Trim). It is advised that to carry out calibration, that a Digital Multi Meter (DMM) is used, so that 4mA or 20mA respectively are shown on the device.

Calibrating 4mA

To calibrate the 4mA, type in '4' in the 'Constant mA' value box and press 'Send'. If the **low value** reading is incorrect, then it can be trimmed using the 'Set 4mA' option. Enter the offset directly into the value box and then select the 'Set 4mA' button to enable you to get the expected result (reading).

Calibrating 20mA

To calibrate the 20mA, type in '20' in the 'Constant mA' value box and press 'Send'. If the **high value** reading is incorrect, then it can be trimmed using the 'Set 20mA' option. Enter the offset directly into the value box and then select 'Set 20mA' button to enable you to get the expected result (reading).

Resume mA

When calibration is complete, to release the constant mA reading select 'Resume mA' which will return you to normal measurement/mA output readings. If this is not selected when calibration is complete, then your mA output will not be updated.

Trace Tab

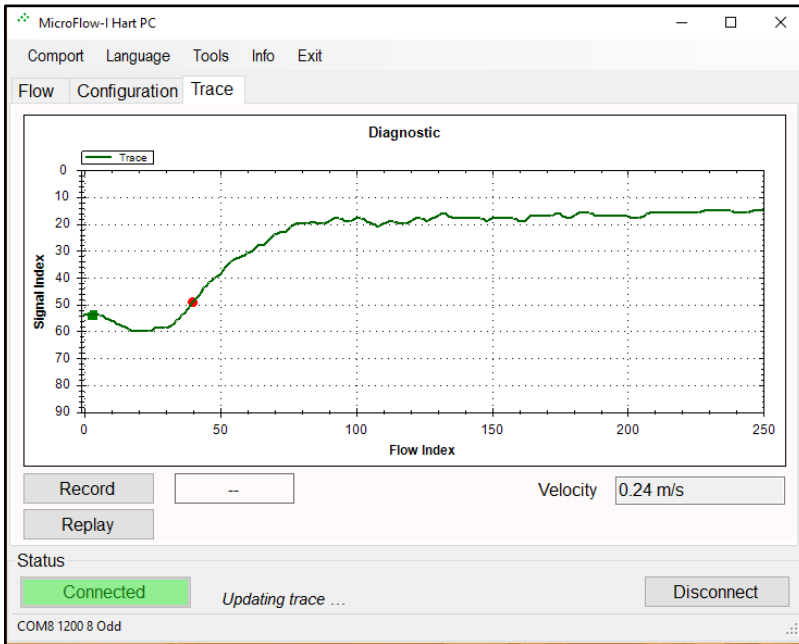

Upon opening the trace tab, the information at the bottom of the screen will scroll through *Measurement in progress*, *updating mA*, *Updating Trace*. Once the trace has updated the diagnostic traces from the sensor will be displayed. You are also able to see the current velocity measurement obtained by the sensor.

The vertical axis is related to the signal strength, while the horizontal axis is related to the detected flow.

When a signal is received, the '**green square indicator**' will move down from 10 on the vertical axis. The further the '**green square indicator**' moves from 10, the larger the strength of the received signal. During flow condition, the '**green square indicator**' will normally be within the range of 30 to 70. Under no-flow conditions the '**green square indicator**' will remain at 10.

When flow is detected, the '**red circle indicator**' will move horizontally to indicate flow detection. The '**red circle indicator**' should stay at 0 under no-flow conditions, and move along the horizontal axis when flow is detected.

Under flow condition, the line should still approach and flatten out at just below the signal index 10 line. If the trace remains flat or the indicators struggle to remain stable during flow, then increase the 'Gain' (P102) setting. You can zoom in by clicking and holding the mouse to draw a box over the region to zoom in on. Zooming out can be done by right clicking on the chart and selecting "Undo All Zoom".

Record Traces

To record traces and the current velocity, select the  button and enter a site ID when prompted to do so. The record button will then change to green whilst the software is recording the data from the sensor. A new trace will be recorded when *Updating Trace....* is shown in the status box.

Replay Traces

To replay trace and velocity data, the sensor needs to be disconnected from the software. Select the  button and a prompt will appear to choose the data file you wish to play. The replay button will change to green whilst the software is replaying the data. During replay select the replay button again to stop.

Important Information

Traces will only be recorded whilst the trace screen is displayed. Upon leaving the trace screen, a message will appear to inform you of this. Returning to the trace screen will resume recording of the trace data.

Comport

If MicroFlow-i PC fails to connect to the sensor, the status condition will appear as below:

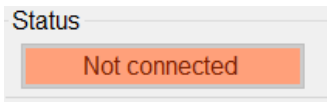

You will need to change the communications port that is being used. To do this, select 'Comport' from the top menu bar and the Comm Port setup window will appear, as seen below:

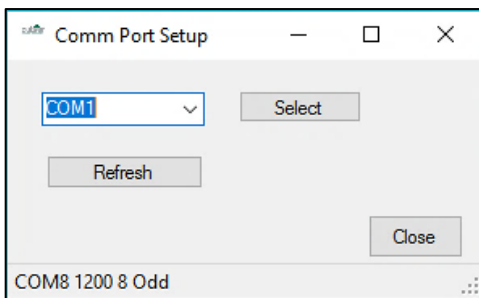

From the drop-down box select the Comport that has been assigned to your HART modem, then press select and then close. Comport assignments can be viewed in the Device Manager area of Microsoft Windows.

Your Comport information will then appear at the bottom of the MicroFlow-i HART PC: `COM 8 1200 8 Odd`

Language

This menu allows you to select the language you wish to view the information on the software in the language option selected.

Tools menu

This menu option allows you to choose the following options:

Convert Logs to CSV

This allows you to export a saved data file (.MLG only) into CSV format. And once opened in Excel, the information recorded in this file can be viewed and each section is labelled at the top of the row: **Date, Time, Velocity**

(m/s), Signal Strength and **Stability**. This information from the MicroFlow-i can then be placed into a chart/graph format.

Change Work Folder

This will allow you to select the default folder for where the trace data files are to be saved to.

Run HART Bootloader Control

This function allows you to reprogram the sensor with HART firmware, and should only be accessed by service personnel or under the guidance of Pulsar service engineers.

Run Bootloader Control

This function allows you to reprogram the sensor with MicroFlow-i firmware, and should only be accessed by service personnel or under the guidance of Pulsar service engineers.

Set Program mode

This allows you to interrogate the sensor and make changes to its parameters, and view traces from the sensor. Whilst in program mode, the mA output will automatically change to high (20mA) allowing the change of parameters to be completed quickly and efficiently. However, the MicroFlow-i will continue to monitor and display any change in velocity and mA readings on the Flow tab.

Set Run mode

This mode is used once the MicroFlow-i has been set up in program mode. It is also the default mode that the sensor is in when a connection is made for the first time to a device, or after a power failure. In run mode no parameters can be changed, and all current readings are reported, and you are able to adjust the 4 – 20mA Trim.

Info

This menu option allows you to choose the following options:

PC Software

This allows you to view the current version of MicroFlow-i HART PC being used.

MicroFlow-i Firmware

When connected to a MicroFlow-i sensor, the information regarding the firmware. Hardware and serial number currently connected is displayed here.

Exit

Disconnects the sensor (leaving it in program mode) and closes MicroFlow-i HART PC.

CHAPTER 6 PARAMETER LISTING AND DESCRIPTION**Parameter Access**

All the MicroFlow-i parameters have factory default values which the user receives upon first use, or when the sensor is reset. The parameters consist of two main types: Device information and Processing parameters.

Device parameters are read only and cannot be set by the user, such as the serial number of the sensor. Processing parameters can be queried and set, there is also an associated access level required for setting, either 'User' or 'Service'. Upon connection to a MicroFlow-i, the access level is defaulted to 'User'.

The parameters are always stored and entered as whole numbers, please refer to the individual parameter for its individual value range.

Device Information Parameters

These parameters are read-only.

NAME	PARAMETER NO.	DESCRIPTION
Serial Number	240 & 241	Registers 240 & 241 form a 32-bit number. Register 240 = Most significant 16-bit. Register 241 = Least significant 16-bit.
Firmware ID	261	A number associated with the version of firmware that is currently programmed onto the sensor.
Hardware ID	262	A number associated with the version of hardware that is currently used with the sensor

Processing Parameters

These parameters relate to the detection and processing of the flow velocity signal.

NAME	PAR NO.	OPTIONS	DEFAULT	NOTES
Gain	102	100 – 1600	120	Used to enter a fixed gain (sensitivity) value, a higher number means higher gain.
Quick Response Damping Factor	104	10 -999	750	When P113=1, this damping factor will be applied. When P113=0, measurement will only be damped by P109 the main damping factor.
Cal Factor	108	1 – 500	100	In percentage terms, default is 100, for 100%. 50% would half and 200% would double.
High/Main Damping	109	0 – 28	0	This sets the damping factor by adding to P104. A higher number represents more damping.
Step Response Mode	113	0 = Off 1 = On	1	When turned off, no damping bypass will be performed.
Low Damping Persist	115	1 – 100	1	This is the number of measurements that the sensor acquires, before switching into damping mode.
High Damping Persist	116	1 – 100	1	This is the number of measurements that the sensor acquires, before switching into Step Response Mode.
No Signal Persist	117	1 – 100	2	This is the number of non-measurement to persist before the sensor sees a state of no signal.

NAME	PAR NO.	OPTIONS	DEFAULT	NOTES
Signal Present Persist	118	1 - 100	2	This is the number of measurements that need to persist for there to be a signal present state.
Minimum Flow Cutoff	120	10 – 4000	150	In units of mm/s velocity for user input, to set the minimum flow velocity present.
Response	125	0 = Instant 1 = Moderate 2 = Damped	Instant	Changing this to 'Instant' will automatically calibrate parameters in the sensor to track measurements faster. This is recommended for Pumped flow. 'Damped' is recommended when there is natural flow, as measurements will be tracked at a slower pace.
Multipoint Calibration @ 0.2 m/s	152	5 – 500	100	In percentage terms, default is 100, for 100%. 50% would half and 200% would double.
Multipoint Calibration @ 0.4 m/s	153	5 – 500	100	In percentage terms, default is 100, for 100%. 50% would half and 200% would double.
Multipoint Calibration @ 0.8 m/s	154	5 – 500	100	In percentage terms, default is 100, for 100%. 50% would half and 200% would double.
Multipoint Calibration @ 1.5 m/s	155	5 – 500	100	In percentage terms, default is 100, for 100%. 50% would half and 200% would double.
Multipoint Calibration @ 3.0 m/s	156	5 – 500	100	In percentage terms, default is 100, for 100%. 50% would half and 200% would double.

NAME	PAR NO.	OPTIONS	DEFAULT	NOTES
Multipoint Calibration @ 5.0 m/s	157	5 – 500	100	In percentage terms, default is 100, for 100%. 50% would half and 200% would double.
Multipoint calibration mode	158	0 = Off 1 = On	1	Turns multipoint calibration on and off
Simulated flow mode	288	0 = Off 1 = On	Off	Switch simulated flow on or off.
Simulated flow velocity mm/s	289	0 – 4000	0	This sets the flow velocity in mm/s, which can be used to simulate velocity and mA readings.
Sensor Reset	297	7 = Default	0	This resets all MicroFlow-i parameters to their default values. (It does not affect any mA Trims applied).

Both P834 and P835 are used for spanning the mA output, by default the 4-20 mA output span is 0 – 6 m/s. Below are some examples of the parameters use:

- Example 1:** 0 – 3m/s span over 4 – 20 mA. Set P835 to 3 (m/s).
- Example 2:** 0 – 6m/s span over 4 – 12mA. Set P835 to 12 (m/s).
- Example 3:** 0 – 6m/s span over 20 – 4 mA. Set P834 to 6 (m/s) and set P835 to 0 (m/s).
- Example 4:** 0 – 6m/s over 8 – 20 mA. Set P834 to -2 (m/s).

Important Information

Traces will only be recorded whilst the trace screen is displayed. Upon leaving the trace screen, a message will appear to inform you of this. Returning to the trace screen will resume recording of the trace data.



If using the MicroFlow-i on an application where Flow type is changed to 'Fast', this will reduce the damping to obtain better results. If there is natural flow and 'Slow' is chosen, then damping is increased to obtain better results.

MicroFlow-i Firmware Upgrade

Firmware upgrades are performed in 'Bootloader' mode, and require service level access. Note: It is advised that reprogramming is carried out by Pulsar service personnel. Also, all flow measurement and output operation will be halted when the sensor is in the 'Bootloader'.

Please follow these steps to reprogram a sensor MicroFlow-i firmware:

1. Please ensure that the sensor is connected to a PC via the HART modem. Prior to reprogramming, you will need the MicroFlow-i firmware file, and the COM port number of the modem.
2. Establish a connection to the sensor.
3. You will require Service access to Run Bootloader Control.
4. Select Tools > Run Bootloader Control, which will then open the Bootloader control interface window as seen in Fig.10.
5. Once connected click 'Load Hex file', and choose the firmware file you are using to upgrade the sensor.
6. Click 'Erase-Program-Verify', and wait for the process to finish.
7. When the 'Verification Successful' message is displayed, click 'Run firmware' and the Bootloader Interface will close.
8. Select the 'Search' button on the software, and the sensor will reconnect to MicroFlow-i HART PC with the new HART firmware installed.

Important Information

It is important to know that it takes approximately 60 minutes to reprogram a sensor with MicroFlow-i firmware successfully.

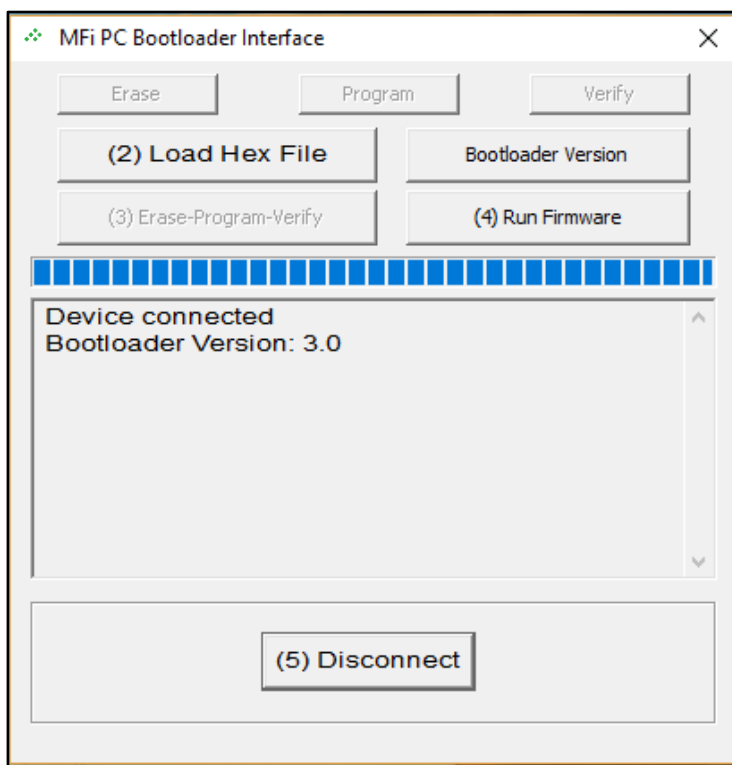

Important Information

Do not switch off supply to the unit or close the software down during the firmware upgrade.

MicroFlow-i HART Firmware Upgrade

- 1.** Please ensure that the sensor is connected to a PC via the HART modem. Prior to reprogramming, you will need the HART firmware file, and the COM port number of the modem.
- 2.** Establish a connection to the sensor.
- 3.** You will require Service access to Run HART Bootloader Control.
- 4.** Select Tools > Run HART Bootloader Control, which will then open the Bootloader control interface window as seen in Fig.11.
- 5.** Once connected click File', and choose the firmware file you are using to upgrade the sensor.
- 6.** Click 'Re-Program', turn the sensor off and on again when prompted to do so by the Bootloader control and then wait for the process to finish.
- 7.** When the 'Program File OK now rebooting' message is displayed, you can close the HART Bootloader and reconnect to the PC software.
- 8.** Select the 'Search' button on the software, and the sensor will reconnect to MicroFlow-i HART PC with the new HART firmware installed.

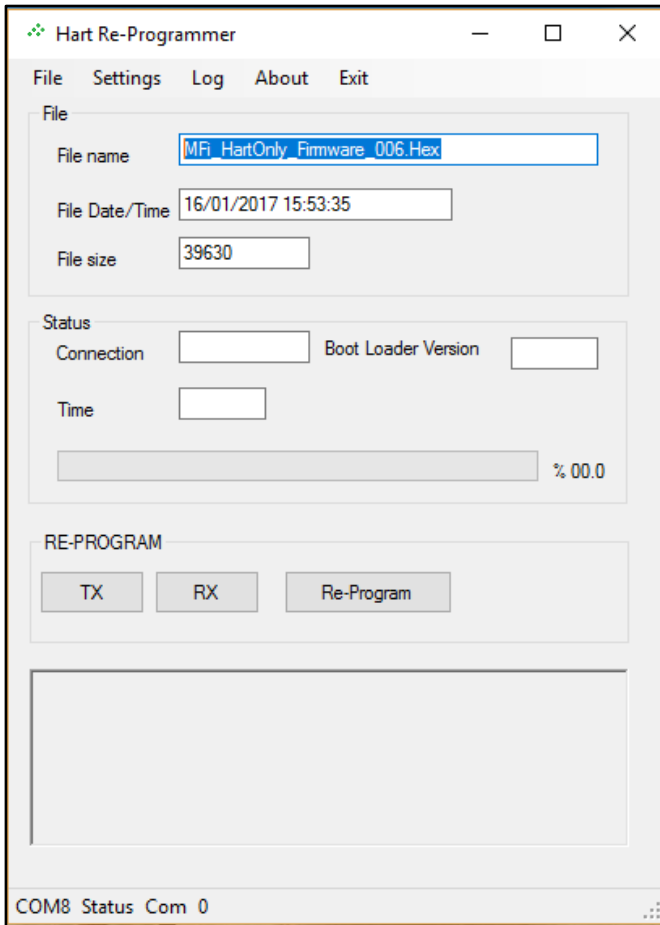

Important Information

Do not switch off supply to the unit or close the software down during the firmware upgrade.

CHAPTER 7 TROUBLESHOOTING

This section describes many common symptoms, with suggestions as to what to do. If the issue persists, please contact your local Pulsar distributor.

SYMPTOM	WHAT TO DO
Currently velocity reads zero, but you know that there is flow movement.	Ensure that the sensor is mounted correctly in accordance with Chapter 2.
Current velocity reading is higher/lower than known movement of flow	Check that the sensor is mounted correctly. Adjust the Gain (P102) or Damping (P109) parameters to obtain correct measurements.
Unable to connect to MicroFlow-i HART PC	Check that wiring to the modem is correct. Close MicroFlow-i HART PC software, cycle power on the sensor and re-open the software. Ensure that the correct Com port has been set and retry connection.
Sensor remains at a high mA out reading (20mA)	Ensure that Simulation mode (P288) is set to 0 = Off. Ensure that 'Resume mA' has been selected if in Run mode.

Important Information

If you experience any issues with our equipment, then please contact your local Pulsar Distributor for assistance.

CHAPTER 8 DISPOSAL

Incorrect disposal can cause adverse effects to the environment.

Dispose of the device components and packaging material in accordance with regional environmental regulations including regulations for electrical \ electronic products.

Transducers

Remove power, disconnect the Transducer, cut off the electrical cable and dispose of cable and Transducer in accordance with regional environmental regulations for electrical \ electronic products.

Controllers

Remove power, disconnect the Controller, and remove battery (if fitted).

Dispose of Controller in accordance with regional environmental regulations for electrical \ electronic products.

Dispose of batteries in accordance with regional environmental regulations for batteries.



 EU WEEE Directive Logo

This symbol indicates the requirements of Directive 2012/19/EU regarding the treatment and disposal of waste from electric and electronic equipment.

NOTES



www.pulsarmeasurement.com

SUPPORT@PULSARMEASUREMENT.COM

Copyright © 2020 Pulsar Measurement Ltd.

Registered Address: 1 Chamberlain Square CS, Birmingham B3 3AX

Registered No.: 3345604 England & Wales

Rev 1.0