



PCMini52

Digital RH & Temperature Mini Probe

User's Manual



97300 Issue 3
January 2018

Please fill out the form(s) below for each instrument that has been purchased.

Use this information when contacting Michell Instruments for service purposes.

Transmitter	
Code	
Serial Number	
Invoice Date	
Location of Instrument	
Tag No	

Transmitter	
Code	
Serial Number	
Invoice Date	
Location of Instrument	
Tag No	

Transmitter	
Code	
Serial Number	
Invoice Date	
Location of Instrument	
Tag No	



PCMini52 Transmitter

For Michell Instruments' contact information please go to
www.michell.com

© 2018 Michell Instruments

This document is the property of Michell Instruments Ltd. and may not be copied or otherwise reproduced, communicated in any way to third parties, nor stored in any Data Processing System without the express written authorization of Michell Instruments Ltd.

Contents

Safety	v
Electrical Safety	v
Toxic Materials	v
Repair and Maintenance	v
Calibration	v
Safety Conformity	v
Abbreviations	vi
1 INTRODUCTION	1
1.1 Features	1
2 INSTALLATION	2
2.1 Wall Mounting	2
2.2 Duct Mounting	2
3 CALIBRATION.....	3

Figures

<i>Figure 1</i>	<i>Wall Mount Position</i>	<i>2</i>
<i>Figure 2</i>	<i>Duct Mount Position.....</i>	<i>2</i>
<i>Figure 3</i>	<i>Integral Electrical Connections.....</i>	<i>3</i>
<i>Figure 4</i>	<i>Dimensions</i>	<i>6</i>

Appendices

Appendix A	Technical Specifications.....	5
	A.1 Dimensions	6
Appendix B	Quality, Recycling & Warranty Information.....	8
Appendix C	Return Document & Decontamination Declaration	10
Appendix D	Recommended Practices in Humidity Measurements.....	12

Safety

The manufacturer has designed this equipment to be safe when operated using the procedures detailed in this manual. The user must not use this equipment for any other purpose than that stated. Do not apply values greater than the maximum value stated.

This manual contains operating and safety instructions, which must be followed to ensure the safe operation and to maintain the equipment in a safe condition. The safety instructions are either warnings or cautions issued to protect the user and the equipment from injury or damage. Use competent personnel using good engineering practice for all procedures in this manual.

Electrical Safety

The instrument is designed to be completely safe when used with options and accessories supplied by the manufacturer for use with the instrument.

Toxic Materials

The use of hazardous materials in the construction of this instrument has been minimized. During normal operation it is not possible for the user to come into contact with any hazardous substance which might be employed in the construction of the instrument. Care should, however, be exercised during maintenance and the disposal of certain parts.

Repair and Maintenance

The instrument must be maintained either by the manufacturer or an accredited service agent. Refer to www.michell.com for details of Michell Instruments' worldwide offices contact information.

Calibration

Michell Instruments recommends an annual calibration for an accuracy requirement of $\pm 2\%$ RH under ambient conditions where temperature is 0 to $+50^{\circ}\text{C}$ ($+32$ to $+122^{\circ}\text{F}$) and relative humidity is 0 to 70% RH. For environments with airborne chemicals or for high humidity and high temperature conditions, Michell recommends more frequent calibration.

Safety Conformity

This product meets the essential protection requirements of the relevant EU directives.

Abbreviations

The following abbreviations are used in this manual:

AC	alternating current
°C	degrees Celsius
°F	degrees Fahrenheit
DC	direct current
g	gram(s)
oz	ounce(s)
sec	second(s)
temp	temperature
V	Volts
"	inch(es)
∅	diameter

1 INTRODUCTION

The micro-processor control and multi-point calibration give the PCMini52 RH probe excellent performance in terms of accuracy and linearity. The mini probe can provide two linear analog outputs for temperature and relative humidity, dew point, absolute humidity or wet bulb temperature.

1.1 Features

- Analog voltage outputs
- Output can be % RH, calculated absolute humidity, dew point or wet bulb temperature and temperature
- Excellent linearity, micro-processor temperature compensated
- Low power consumption, fast settling time
- Small size: L = 80mm, \varnothing 12mm (L = 3.15", \varnothing 0.47")
- Stainless steel and molded polymer variants

2 INSTALLATION

2.1 Wall Mounting

The PCMini52 can be used for wall mounting and must always be installed with the sensing element facing downwards so as to minimize the propagation of heat between the transmitter and the sensitive element. It should be attached to the wall with a mounting clip.

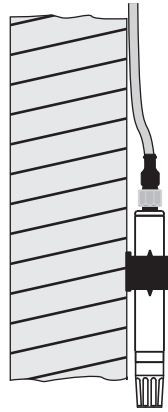

Figure 1 Wall Mount Position

2.2 Duct Mounting

The PCMini52 can be used for duct mounting and must be installed so that the end of the sensor body (the filter) comes into contact, perpendicularly, with the flow of air from which the relative humidity is to be measured.

An extra opening should be made in the air duct close to the opening for the installation of the sensor in order that checks and further calibration may be performed, when required.

If necessary, an appropriate form of thermal insulation should be placed between the walls of the duct and the transmitter housing.

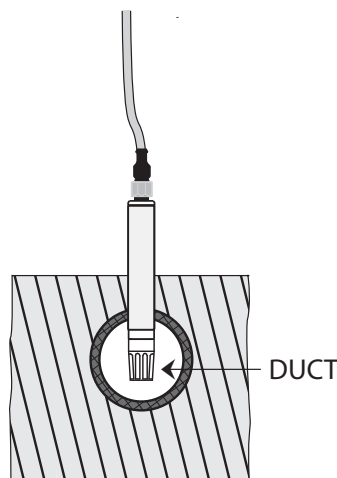

Figure 2 Duct Mount Position

3 CALIBRATION

The transmitter is calibrated at two points.

Mating Cable		
Color	Pin	
Brown	1	Supply voltage V +
White	2	Output RH, Dew point or Absolute humidity
Black	4	Output temperature
Blue	3	Common ground

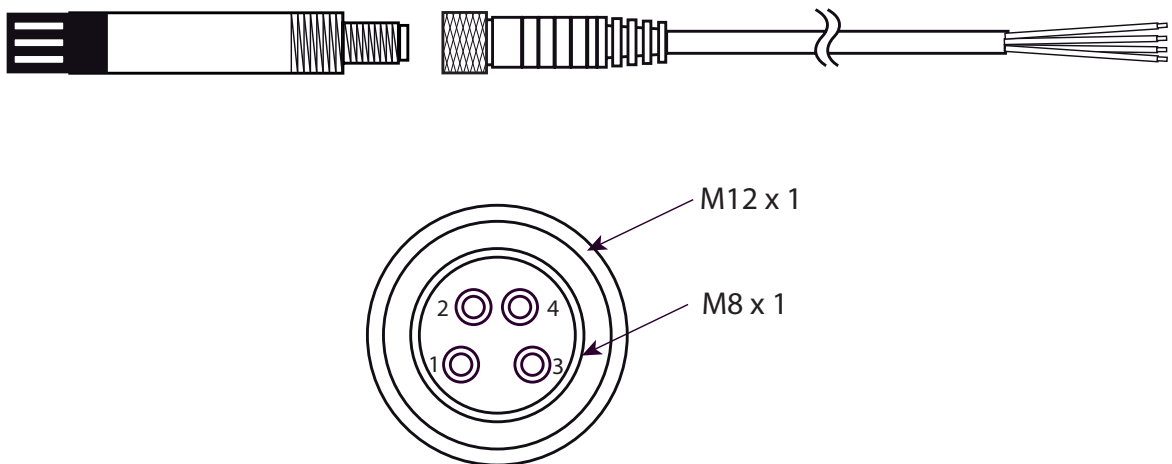

Figure 3 *Integral Electrical Connections*

Appendix A

Technical Specifications

Appendix A Technical Specifications

Performance	
Measurement Range (RH)	0–100% RH
Measurement Range (T)	-20 to +80°C (-4 to +176°F)
Accuracy at 23°C (73°F) Humidity	<±2% RH (10–90% RH)
Accuracy at 23°C (73°F) Temperature	±0.2°C (±0.36°F)
Stability – RH Sensor	±1% RH/year
Response Time – RH Sensor	<10 sec typical (for 90% of the step change)
Electrical Specifications	
Output Signal Options	0 to 1, 0 to 5, 0 to 10 V
Supply Voltage	14 to 35 V DC (for 0 to 5 / 10 V output) 6 to 35 V DC (for 0 to 1 V output)
Current Consumption	4 mA on a typical voltage load
CE Marked	Certified
Operating Specifications	
Operating Temperature Sensing Element	-30 to +85°C (-22 to +185°F)
Housing	-30 to +85°C (-22 to +185°F)
Storage	-40 to +85°C (-40 to +185°F)
Mechanical Specifications	
Ingress Protection	IP65 (NEMA 4 level)
Housing Material	Molded polymer / stainless steel (options)
Dimensions	L=80mm, ø12mm (L=3.15", ø0.47")
Filter	PVDF / HDPE / mesh / sintered (options)
Weight	10g (0.35oz)
Electrical Connections	4 pin, M8 connector

A.1 Dimensions

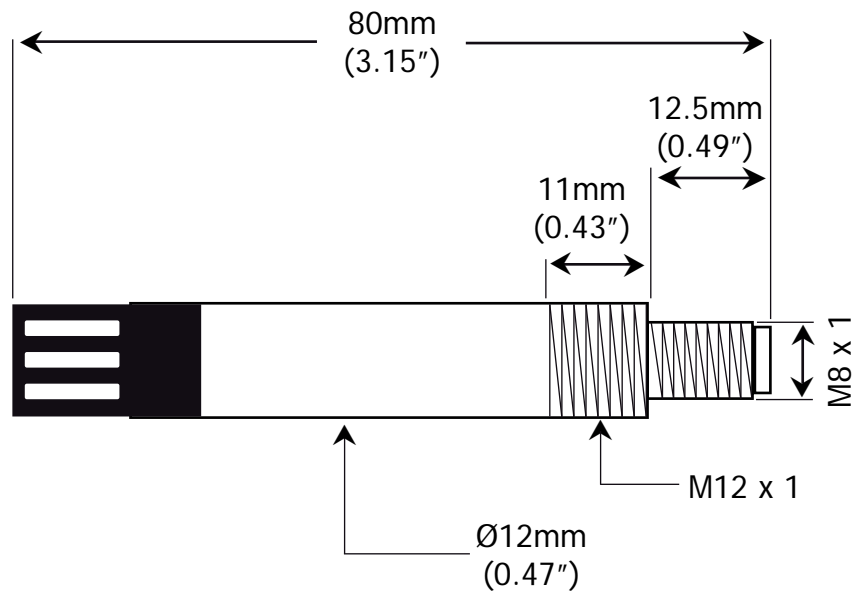
Figure 4 *Dimensions*

Appendix B

Quality, Recycling & Warranty Information

Appendix B Quality, Recycling & Warranty Information

Michell Instruments is dedicated to complying to all relevant legislation and directives. Full information can be found on our website at:

www.michell.com/compliance

This page contains information on the following directives:

- ATEX Directive
- Calibration Facilities
- Conflict Minerals
- FCC Statement
- Manufacturing Quality
- Modern Slavery Statement
- Pressure Equipment Directive
- REACH
- RoHS2
- WEEE2
- Recycling Policy
- Warranty and Returns

This information is also available in PDF format.

Appendix C

Return Document & Decontamination Declaration

Appendix C Return Document & Decontamination Declaration

Decontamination Certificate

IMPORTANT NOTE: Please complete this form prior to this instrument, or any components, leaving your site and being returned to us, or, where applicable, prior to any work being carried out by a Michell engineer at your site.

Instrument			Serial Number	
Warranty Repair?	YES	NO	Original PO #	
Company Name			Contact Name	
Address				
Telephone #			E-mail address	
Reason for Return /Description of Fault:				
Has this equipment been exposed (internally or externally) to any of the following? Please circle (YES/NO) as applicable and provide details below				
Biohazards			YES	NO
Biological agents			YES	NO
Hazardous chemicals			YES	NO
Radioactive substances			YES	NO
Other hazards			YES	NO
Please provide details of any hazardous materials used with this equipment as indicated above (use continuation sheet if necessary)				
Your method of cleaning/decontamination				
Has the equipment been cleaned and decontaminated?			YES	NOT NECESSARY
Michell Instruments will not accept instruments that have been exposed to toxins, radio-activity or bio-hazardous materials. For most applications involving solvents, acidic, basic, flammable or toxic gases a simple purge with dry gas (dew point <-30°C) over 24 hours should be sufficient to decontaminate the unit prior to return. Work will not be carried out on any unit that does not have a completed decontamination declaration.				
Decontamination Declaration				
I declare that the information above is true and complete to the best of my knowledge, and it is safe for Michell personnel to service or repair the returned instrument.				
Name (Print)			Position	
Signature			Date	

Appendix D

Recommended Practices in Humidity Measurement

Appendix D Recommended Practices in Humidity Measurements

The following text is reproduced with kind permission from the National Physical Laboratory. It is originally published in the booklet, *A Guide to the Measurement of Humidity*.

Definition of Relative Humidity

Relative Humidity – The ratio of the actual vapor pressure to the saturation vapor pressure over a plane liquid water surface at the same temperature, expressed as a percentage. This is commonly understood when the term 'X percent relative humidity' is used.

For actual vapor pressure, e , and saturation vapor pressure, e_s

$$\text{relative humidity (in \%)} = \frac{e}{e_s} \times 100$$

USAGE: The phrase 'relative humidity' is commonly abbreviated RH although this is not a recognized abbreviation. Values of relative humidity are commonly expressed in units of percent relative humidity (% RH).

Recommended practices in humidity measurements

General practical recommendations

- Where relative humidity is of interest, a direct measurement of relative humidity is usually best. Where an absolute measure of humidity is needed, choose dew point, vapor pressure or similar measurements.
- Establish the measurement requirements at the purchasing stage in order to have the right instrument for the job.
- Allow hygrometers to equilibrate in any new environment. This is particularly necessary after changes in temperature due to transportation or storage. Depending on the instrument and on how great the change in conditions, this may require from only a few minutes to many hours.
- Follow Michell Instruments' care instructions for the instrument. Some instruments need routine cleaning or other maintenance. Before using any solvent cleaner, check with Michell Instruments that this will not harm the sensor or other materials of construction.
- Wherever possible, ensure that hygrometers are calibrated under the conditions of use, i.e. at similar values of humidity and temperature, and (if relevant) in similar conditions of pressure, airflow, etc.
- Keep a record of calibrations and any adjustments to the hygrometer. This will show the long-term stability of the instrument and allow the associated uncertainty to be assessed.
- Check instruments, if possible, at intervals between calibrations, by comparison with another (stable) instrument, to monitor for long-term drift. Routine checks are also useful before and after subjecting an instrument to transportation or other stress, which might lead to a shift in its performance. Where the check is against two (or more) instruments this is even better: not only does this add confidence, but in the event of one instrument drifting among a set of three, it can be seen which reading is most suspect.
- Cleanliness of the environment will affect different hygrometers in different ways. Dust and airborne droplets should be avoided or filtered out if possible. Contaminants can come from the most surprising sources, ordinary urban pollution, for example.

- The readings given by some types of hygrometer are sensitive to gas type. For any Instrument which reads in terms of mass per unit volume, e.g. in grams per cubic metre, it must be confirmed whether the calibration is valid for the gas in use.
- Avoid using instruments in direct sunlight or near any other source of heat, unless they are suitably shielded to prevent measurement errors.

Sampling in general

- Relative humidity measurements should be carried out at a representative temperature. Failure to allow temperature equilibration will lead to a false indication of the relative humidity.
- Variations in vapor pressure from place to place can occur where an environment is subject to any addition or removal of water. If so, care must be taken over where to make a measurement in order to obtain a representative result.
- Sources and sinks of water vapor should be avoided in any sampling system. Invasion of stray water can be minimised by attention to leaks, hygroscopic materials, droplets and condensation. The lower the humidity, the more critical these precautions are.
- Hygroscopic materials should be avoided. Many materials contain moisture as part of their structure, particularly organic materials (whether natural or synthetic), salts (or anything which contains them), and anything which has small pores. Temperature changes can increase the tendency of these materials to affect the humidity of the surrounding air.
- Condensation in a sampling process can invalidate humidity measurements by reducing the water content of the gas being measured. What is more, condensed liquid may alter the humidity elsewhere by dripping or running to other locations and evaporating there. In these circumstances, measurement results may be misleading if hygrometer location is not considered carefully.
- Water droplets or mist must be avoided. These can result in overestimates of the humidity of the air between the droplets. Such results may exceed 100% RH, or may be impossible to interpret meaningfully. Droplets of liquid also damage some electrical types of humidity sensor. Filtering the air sample can eliminate droplets.
- If pumps are used for sampling gas, these should be located after the hygrometer, to avoid contaminating the measurement environment. Where possible, oil free pumps should be used, or filters employed. Oscillations in pressure due to pumping can sometimes be reduced or buffered using a needle valve or a reservoir of large volume.
- Special treatments such as filtration can change the amount of moisture in a gas. Some drying agents take out other gases too.
- When sealing any sensor or probe into a port or manifold in a duct or chamber, leaks through the probe or electrical cable should be considered. These are not always sealed against passage of ambient air.
- Where sampling involves a step change in temperature, pressure or gas flow rate, relative to the process being sampled, results may need to be converted or interpreted. For example 'pressure dew point' will differ from the value found after expanding the gas sample to atmospheric pressure. Care should be taken to distinguish between 'gauge' and absolute values of pressure.

Dew point in general

- The measuring environment and all parts of the sampling pathway must be kept above the dew point if condensation is to be avoided. Electrical trace heating or other heating methods should be used if necessary. An excess temperature of 10°C above the dew point is usually a safe margin.

- For measurements in the region below 0°C it must be clear whether the condensate is dew or frost. Failure to distinguish between these can result in errors of about 1°C for every 10°C below zero.

Relative humidity in general

- Due care must be taken of temperature. The effect of temperature on humidity is highly significant. Failure to take this into account can sometimes lead to errors so large that the measurement is meaningless. In many situations, the largest single source of uncertainty in a humidity measurement is the effect of temperature differences from place to place in the process, room or chamber. The importance of considering the temperature effects carefully cannot be overstated when relative humidity is the parameter of interest.
- Care must be taken when expressing uncertainties, changes or fractional differences in relative humidity. For example, the difference between 50% RH and 52% RH is 2% RH. This can also be expressed as a difference of 4% of value. It is important to distinguish clearly between these two kinds of statement.

Recommendations specific to ranges of measurements

- Ambient humidity - Avoid using hygrometers near the body, which is a source of heat and moisture. Do not breathe close to the measurement.
- High humidity, above the ambient range - Sample lines should be maintained above the dew point of the gas being measured, to avoid condensation. Electrical trace heating is often the most practical method.
- Low humidity, and very dry gases - If possible, prepare for measurements by flushing sample lines and hygrometers with dry gas, or by evacuating to low pressure. Drive off stray residual water by baking assemblies if possible (but not instruments – unless designed for this!). The lower the moisture content to be measured, the more dramatically the required drying time multiplies.
- Avoid hygroscopic materials. At low humidity (anything much below a dew point of 0°C) the amounts of water given off by organic and porous materials can dramatically affect the value of humidity. The lower the level of moisture, the more significant the effects.
- Choose impermeable materials, to avoid inward diffusion of moisture through sampling tubes and enclosures. Steel and other metals are practically impermeable. PTFE ('Teflon') is only slightly permeable and will usually be satisfactory for dew points above -20°C, and sometimes below this level. Materials such as PVC and rubber are relatively permeable and so totally unsuitable at low humidity, and not really satisfactory in any humidity range.
- Surface finish of pipework is important for very dry gases. Even the tiny quantities of water adsorbed on the surfaces of non-hygroscopic materials can have significant effect. Polished or electropolished steel is recommended for the best results.
- Clean environments are always best for humidity measurements, but this is especially critical at very low humidity. Even fingerprints harbour water. High purity cleaning agents are recommended: Analytical Reagent (AR) quality solvents for oil-based contaminants, and purified water (distilled or de-ionised) for salts. Cleaning should be followed by thorough drying by a clean method.
- Sample tubing should be as short in length as possible. The surface area should be minimised by using the narrowest tubing that the flow conditions will permit.
- Avoid leaks. Minimising the number of connections (elbows, tees, valves, etc.) helps with this.
- Adequate flow of the gas sample should be ensured, to minimise the influence of sources of stray water in the flow path.
- 'Dead ends' should be avoided, as they cannot easily be flushed.

- Back-diffusion of moisture should be minimised, e.g. by fast flow rates of gas, long exhaust tubes after the sensor, or by valves which isolate the low-humidity region from ambient air.

Practical recommendations for specific types of hygrometer

Relative humidity capacitive sensor

- Care should be taken to avoid mechanical shock (impact) or thermal shock (sudden temperature changes). Sensors should be protected from steam or water sprays, and from direct sunlight.
- Where a sensor is at risk of exposure to dust, droplets, or the occasional knock during handling, the appropriate guard or filters for the sensor head should be used.
- Any temptation to breathe on the sensor, or to wave it over cups of tea, etc. should be resisted. Filters and saturation guarding may protect the sensor, but these actions carry a risk of damage by condensation or other contamination.
- Protective filters can slow the response time of sensors. This can be avoided by removing any filter, but the benefit must be weighed against the risk of damage to the sensor.
- Sensors should not normally be submerged in liquids. In the case of a resistive (electrolytic) sensor, water or other liquids would certainly damage the sensor beyond repair.
- Salt solutions are especially commonly used for calibration of electrical sensors, and should be provided with traceability directly or via a calibrated hygrometer. Protection of sensors from direct contact with salt or solution is most important as contamination would destroy or seriously impair the sensing element.

NOTES:

Manufacturer: **Michell Instruments Benelux B.V.**
Krombraak 11
4906 CR Oosterhout
The Netherlands.



We declare under our sole responsibility that the product:

PC mini 52 RH & Temperature Transmitter

complies with all the essential requirements of the EU directives listed below.

2014/30/EU **EMC Directive**

2011/65/EU **Restriction of Hazardous Substances Directive (RoHS2)**

Using the standards:

EN61326-1:2013 Electrical equipment for measurement, control and laboratory use – EMC requirements – Group 1, Class B (emissions) and immunity.

and has been designed to be in conformance with the relevant sections of the following standards or other normative documents.

EN61010-1:2010 Safety Requirements for Electrical Equipment for Measurement, Control, and Laboratory Use - Part 1: General Requirements

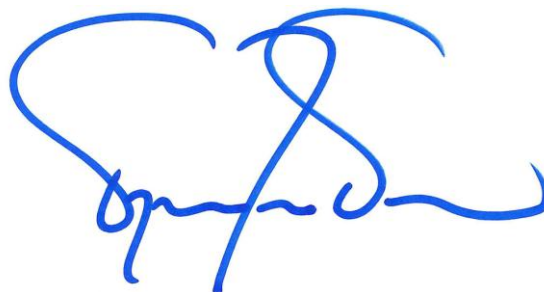

Robert-Jan Pouw RH Business Manager.
Michell Instruments Benelux B.V. Oosterhout The Netherlands
Date of Issue 6 December 2017

on behalf of
Peter Haakma Managing Director Michell Instruments Benelux B.V.



<http://www.michell.com>