

PD6800 Explosion-Proof Loop-Powered Process Meter

Instruction Manual



- Fully-Approved Explosion-Proof Loop-Powered Meter
- 4-20 mA Input with $\pm 0.03\%$ Accuracy
- 3.0 Volt Drop (6.0 Volt Drop with Backlight)
- Easy Field Scaling in Engineering Units without Applying an Input
- 0.7" (17.8 mm) 5 Digits Upper Display
- 0.4" (10.2 mm) 7 Alphanumeric Characters Lower Display
- Display Mountable at 0°, 90°, 180°, & 270°
- SafeTouch™ Through-Glass Button Programming
- HART® Protocol Transparent
- Loop or External DC-Powered Backlight Standard
- Operating Temperature Range: -40 to 75°C (-40 to 167°F)
- FM Approved as Explosion-Proof / Dust-Ignition Proof / Flame-Proof
- CSA Certified as Explosion-Proof / Dust-Ignition Proof / Flame-Proof
- ATEX and IECEx Certified as Flame-Proof and Protection by Enclosure
- Conformal Coated PCBs for Dust and Humidity Protection
- Password Protection
- 32-Point Linearization, Square Root Extraction and Programmable Exponent Function
- Wide Viewing Angle
- Flanges for Wall or Pipe Mounting
- Explosion-Proof, IP68, NEMA 4X Die-Cast Aluminum Enclosure
- Two 3/4" NPT Threaded Conduit Openings (One Plug Installed)
- 2" U-Bolt Kits Available
- 3-Year Warranty

PRECISION DIGITAL CORPORATION

233 South Street • Hopkinton MA 01748 USA
Tel (800) 343-1001 • Fax (508) 655-8990

www.predig.com

PRECISION
DIGITAL

Disclaimer

The information contained in this document is subject to change without notice. Precision Digital Corporation makes no representations or warranties with respect to the contents hereof; and specifically disclaims any implied warranties of merchantability or fitness for a particular purpose.

CAUTION

- Read complete instructions prior to installation and operation of the meter.

WARNINGS

- Risk of electric shock or personal injury.
- This product is not recommended for life support applications or applications where malfunctioning could result in personal injury or property loss. Anyone using this product for such applications does so at his/her own risk. Precision Digital Corporation shall not be held liable for damages resulting from such improper use.
- Failure to follow installation guidelines could result in death or serious injury. Make sure only qualified personnel perform the installation.
- Never remove the meter cover in explosive environments when the circuit is live.
- Cover must be fully engaged to meet flameproof/explosion-proof requirements.

WARNING
 Cancer and Reproductive Harm - www.P65Warnings.ca.gov

Limited Warranty

Precision Digital Corporation warrants this product against defects in material or workmanship for the specified period under "Specifications" from the date of shipment from the factory. Precision Digital's liability under this limited warranty shall not exceed the purchase value, repair, or replacement of the defective unit. See Warranty Information and Terms & Conditions on www.prediq.com for complete details.

© 2022 Precision Digital Corporation.
 All rights reserved.

Introduction

The PD6800 is a rugged, explosion-proof loop-powered meter fully featured for demanding applications in hazardous areas or in the harshest environmental conditions. The meter derives all its power from the 4-20 mA loop. It is programmed using the four SafeTouch through-glass buttons, without removing the cover, and can be scaled with or without a calibration signal. The numeric display will read up to 99999 and the alphanumeric display can be programmed to show any combination of numbers and letters up to seven characters long for use as engineering units, the process identification tag or a display for the calculated volume when using for level applications. The backlight lets you see the display under any lighting condition and can be powered from either the 4-20 mA loop or from a separate DC power supply.

The enclosure is provided with two threaded conduit holes and integrated pipe or wall mounting slotted flanges.

Ordering Information

Model	Description
PD6800-0K0	Explosion-Proof Loop-Powered Process Meter with Backlight

Accessories

Model	Description
PDA0001	3/4" M-NPT to F-M20 Reducer
PDA0002	3/4" M-NPT to 1/2" F-NPT Reducer
PDA1024-01	24 VDC Power Supply for DIN Rail
PDA6846	Steel 2" U-Bolt Kit. All Material: Zinc Plated Steel; (1) U-Bolt for 2" Pipe with (2 each) Washers, Lock Washers, and Nuts.
PDA6846-SS	Stainless Steel 2" U-Bolt Kit. All Material: Stainless Steel; (1) U-Bolt for 2" Pipe with (2 each) Washers, Lock Washers, and Nuts.
PDA-SSTAG	Custom Stainless Steel Tag (see website for convenient ordering form)

Helpful Videos

The following videos might be of interest.

ProtEX Explosion-Proof Meter Introduction

Learn about all the meters in the ProteX Series.



https://www.predig.com/videos/rJsvL_8PEyc

ProtEX Approvals Overview

The ProtEX Series carries extensive international approvals for hazardous areas.



<https://www.predig.com/videos/CTsNXQeRqTA>

ProtEX Enclosure Unique Features

Learn about the unique features of the ProtEX Series enclosures.



<https://www.predig.com/videos/SwWKJ3L8ibo>

Introduction to ProtEX SafeTouch Programming

Through-glass buttons make programming easy without removing the enclosure's cover.



https://www.predig.com/videos/SafeTouch_Buttons

ProtEX-F&I Loop-Powered Level Meter

The PD6801 level meter displays level in feet and inches, providing simple and easy-to-understand level indication.



<https://www.predig.com/videos/AkWDnB-XI9k>

Vantageview Series Introduction

This series designed for use in safe areas delivers the same functionality of the ProtEX Series in a rugged plastic enclosure.



https://www.predig.com/videos/OC_trhGqTWU

Table of Contents

Introduction	2
Ordering Information	2
Specifications.....	6
General	6
Input.....	6
Product Ratings and Approvals	7
Electromagnetic Compatibility	7
EU Declaration of Conformity	8
Safety Information	8
Installation.....	9
Unpacking	9
Pre-Installed Conduit Plug.....	9
Mounting	9
Dimensions	9
Cover Jam Screw.....	10
Connections.....	10
Wiring Diagrams	11
Setup and Programming	12
Overview.....	12
SafeTouch Buttons.....	12
SafeTouch Button Tips and Troubleshooting	12
Buttons and Display	13
Main Menu Display Functions & Messages	14
Main Menu	14
Setting Up the Meter (SETUP)	14
Setting Numeric Values.....	15
Setting the Decimal Point (dECPt)	15
Programming the Meter (PrOG)	15
Scaling the Meter (SCALe)	15
Calibrating the Meter (CAL).....	16
Minimum Input Span	16
Re-Calibrating the Internal Calibration Reference (ICAL).....	16
Setting the Tag Display (TAG)	16
Setting Up the Password (PASSWD).....	17
Locking the Meter.....	17
Setting Up the Meter (SETUP)	17
Making Changes to a Password Protected Meter	17
Disabling Password Protection.....	17
Service Feature (SERVICE).....	17
Advanced Features Menu	18
Advanced Features Menu & Display Messages.....	18
Indication (INDICAT).....	19
Alarm (ALARM).....	19
Advanced Function Selection (FUNCTION)	19
Multi-Point Linearization (LEAr).....	19
Multi-Point Scaling (SCALe)	20
Multi-Point Calibration (CAL).....	20
Square Root Linearization (SQUR)	20
Low-Flow Cutoff (CUTOFF)	20
Programmable Exponent Linearization (PrOGe).....	21
Input Signal Filter (FILTER)	21
Internal Calibration (ICAL).....	21
Error Message (SPAn ERROR).....	21
Information (INFO).....	21

Operation22
 Front Panel Buttons Operation22
 Maximum & Minimum Readings (MAXIMUM & MINIMUM).....22
 Reset Meter to Factory Defaults.....22
 Factory Defaults & User Settings.....22
 Troubleshooting.....23
 Troubleshooting Tips.....23
 Quick User Interface Reference.....24

Table of Figures

Figure 1. Enclosure Dimensions – Front View.....9
 Figure 2. Enclosure Dimensions – Side Cross Section View9
 Figure 3. Connector Board.....10
 Figure 4. Connections without Backlight11
 Figure 5. Connections with Loop-Powered Backlight.....11
 Figure 6. Connections with Externally-Powered Backlight11

Specifications

Except where noted all specifications apply to operation at +25°C.

General

Display	Five digits (-9999 to 9999)	0.70" (17.8 mm) high, 7-segment, automatic lead zero blanking.
	Seven characters	0.4" (10.2 mm) high, 14-segment.
	Symbols	High & Low Alarm, Password Lock
Display Orientation	Display may be mounted at 90° increments up to 270° from default orientation.	
Display Assignment	Lower display may be assigned to custom unit or tag.	
Display Update Rate	Ambient > -25°C: 2 Updates/Second Ambient < -25°C: 1 Update/5 Seconds	
Backlight	White; Loop-powered or externally powered. Backlight can be enabled or disabled via alternative wiring of terminal block. Loop-powered backlight brightness will increase as the input signal current increases. Externally powered backlight has consistent brightness.	
Externally Powered Backlight	Voltage Range:	Maximum Power
	9-36 VDC	9 VDC 12 VDC 24 VDC 36 VDC
		0.2 W 0.25 W 0.5 W 0.75 W
	Display Overrange	Display flashes 99999
	Display Underrange	Display flashes -9999
Programming Method	Four SafeTouch through-glass buttons when cover is installed. Four internal pushbuttons when cover is removed.	
Noise Filter	Programmable LQ , Ed , H I , or OFF	
Recalibration	Recalibration is recommended at least every 12 months.	
Max/Min Display	Max/Min readings reached by the process are stored until reset by the user or until power to the meter is turned off.	
Advanced Function	Linear, square root, or programmable exponent	
Password	Programmable password restricts modification of programmed settings.	
Non-Volatile Memory	All programmed settings are stored in non-volatile memory for a minimum of ten years if power is lost.	
Normal Mode Rejection	64 dB at 50/60 Hz	
Environmental	Operating temperature range: -40 to 75°C Storage temperature range: -40 to 75°C Relative humidity: 0 to 90% non-condensing	
Connections	Screw terminals accept 12 to 22 AWG wire	
Enclosure	Explosion-proof die cast aluminum with glass window, corrosion resistant epoxy coating, color: blue. NEMA 4X, 7, & 9, IP68. Two ¾" NPT threaded conduit openings. One ¾" NPT metal conduit/stopping plug with 12 mm hex key fitting installed.	
Mounting	May be mounted directly to conduit. Two slotted flanges for wall mounting or NPS 1½" to 2½" or DN 40 to 65 mm pipe mounting. See <i>Dimensions</i> on page 9.	
Overall Dimensions	5.65" x 5.25" x 4.86" (W x H x D) (144 mm x 133 mm x 124 mm)	
Weight	5.00 lbs (80 oz, 2.27 kg)	
Warranty	3 years parts and labor. See Warranty Information and Terms & Conditions on www.predig.com for complete details.	

Input

Input	4-20 mA	
Accuracy	±0.03% of calibrated span ±1 count, square root & programmable exponent accuracy range: 10-100% of calibrated span.	
Maximum Voltage Drop & Equivalent Resistance	Without Backlight or with Externally Powered Backlight	With Loop-Powered Backlight
	3.0 VDC @ 20 mA 150 Ω @ 20 mA	6.0 VDC @ 20 mA 300 Ω @ 20 mA
Temperature Drift	50 PPM/°C from -40 to 75°C ambient	
Multi-Point Linearization	2 to 32 points	
Programmable Exponent	User selectable from 1.0001 to 2.9999 for open channel flow	
Low Flow Cutoff	0-99999 (0 disables cutoff function) Point below at which display always shows zero.	
Decimal Point	User selectable decimal point	
Minimum Span	Input 1 & Input 2: 0.10 mA	
Calibration Range	An <i>Error</i> message will appear if input 1 and input 2 signals are too close together.	
	Input Range	Minimum Span Input 1 & Input 2
	4-20 mA	0.10 mA
Input Overload	Over current protection to 2 A max.	
HART Transparency	The meter does not interfere with existing HART communications; it displays the 4-20 mA primary variable and it allows the HART communications to pass through without interruption. The meter is not affected if a HART communicator is connected to the loop. The meter does not display secondary HART variables.	

Product Ratings and Approvals

FM	Explosion-proof for use in: Class I, Division 1, Groups B, C and D Dust-ignition proof for use in: Class II/III, Division 1, Groups E, F and G; T6 Flame-proof for use in: Class I, Zone 1, AEx d Group IIC; T6 Protection by Enclosure: Zone 21, AEx tb IIIC; T85°C Ta = -40 to 75°C. Enclosure: Type 4X, IP66. Certificate number: 3040391
CSA	Explosion-proof for use in: Class I, Division 1, Groups B, C and D Dust-ignition proof for use in: Class II/III, Division 1, Groups E, F and G; T6 Flame-proof for use in: Zone 1, Ex d IIC T6 Ta = -40 to 75°C. Enclosure: Type 4X & IP66/IP68. Certificate number: 2325749
ATEX	 II 2 G D. Flame-proof for use in: Zone 1, Ex d IIC T6 Gb Protection by Enclosure for use in: Dust Atmospheres (Zone 21) Ex tb IIIC T85°C Db IP68. Ta = -40°C to +75°C Certificate number: Sira 10ATEX1116X
IECEX	Flame-proof for use in: Zone 1, Ex d IIC T6 Gb Protection by Enclosure for use in: Dust Atmospheres (Zone 21) Ex tb IIIC T85°C Db IP68. Ta = -40°C to +75°C Certificate number: IECEX SIR 10.0056X

Electromagnetic Compatibility

Emissions	EN 61326 Safety requirements for measurement, control, and laboratory use – Industrial Group 1 Class A ISM emissions requirements
Radiated Emissions	Class A
Immunity	EN 61326 Safety requirements for measurement, control, and laboratory use
ESD	±4 kV contact, ±8 kV air
RFI – Amplitude Modulated	80-1000 MHz @ 10 V/m, 1.4-2.0 GHz @ 3 V/m, 2.0-2.7 GHz @ 1 V/m, 80% AM (1 kHz)
EFT	±2 kV DC mains, ±1 kV other
Telco Surge	±1 kV
CRFI	3 V, 0.15-80 MHz, 1 kHz 80% AM

Special Conditions for Safe Use:

Use suitably certified and dimensioned cable entry device and/or plug. The equipment shall be installed such that the supply cable is protected from mechanical damage. The cable shall not be subjected to tension or torque. If the cable is to be terminated within an explosive atmosphere, then appropriate protection of the free end of the cable shall be provided.

Year of Construction:

This information is contained within the serial number with the first four digits representing the year and month in the YYMM format.

For European Community: The PD6800 must be installed in accordance with the ATEX directive 94/9/EC, and the product certificate Sira 10ATEX1116X.

EU Declaration of Conformity

EU Declaration of Conformity is available in the Documentation CD provided with the product under the **EU DoC** menu.

Safety Information

WARNINGS

- Read complete instructions prior to installation and operation of the meter.
 - Installation and service should be performed only by trained service personnel. Service requiring replacement of internal components must be performed at the factory.
 - Disconnect from supply before opening enclosure. Keep cover tight while circuits are alive. Conduit seals must be installed within 18" (450mm) of the enclosure.
 - Verify that the operating atmosphere of the meter is consistent with the appropriate hazardous locations certifications.
 - If the meter is installed in a high voltage environment and a fault or installation error occurs, high voltage may be present on any lead.
-

Installation

For Installation in USA: The PD6800 must be installed in accordance with the National Electrical Code (NEC) NFPA 70.

For Installation in Canada: The PD6800 must be installed in accordance with the Canadian Electrical Code CSA 22.1. All input circuits must be derived from a CSA approved Class 2 source.

For European Community: The PD6800 must be installed in accordance with the ATEX directive 94/9/EC and the product certificate Sira 10ATEX1116X.

⚠ WARNING

- Disconnect from supply before opening enclosure. Keep cover tight while circuits are alive. Conduit seals must be installed within 18" (450mm) of the enclosure.

Wiring connectors are accessed by opening the enclosure. To access electrical connectors, remove the 2 captive screws, then disconnect the ribbon cable from the display module and set the display module aside.

Unpacking

Remove the meter from box. Inspect the packaging and contents for damage. Report damages, if any, to the carrier.

If any part is missing or the meter malfunctions, please contact your supplier or the factory for assistance.

Pre-Installed Conduit Plug

The PD6800 is supplied with one pre-installed conduit plug for installations that do not require the use of both conduit entries. The conduit/stopping plug includes an internal hexagonal socket recess for removal. The conduit plug and its factory installation are included in all hazardous area approvals of this product.

⚠ WARNING

- In hazardous areas, conduit and conduit/stopping plugs require the application of non-setting (solvent free) thread sealant. It is critical that all relevant hazardous area guidelines be followed for the installation or replacement of conduit or plugs.

Mounting

The PD6800 has two slotted mounting flanges that may be used for pipe mounting or wall mounting. Alternatively, the unit may be supported by the conduit using the conduit holes provided. Refer to *Figure 1* and *Figure 2*.

⚠ WARNING

- Do not attempt to loosen or remove flange bolts while the meter is in service.

Dimensions

All units: inches [mm]

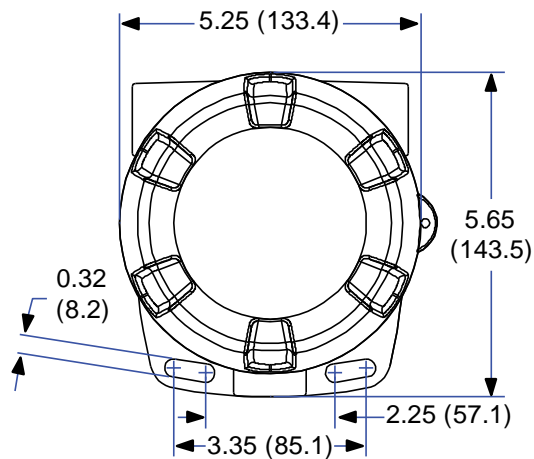

Figure 1. Enclosure Dimensions – Front View

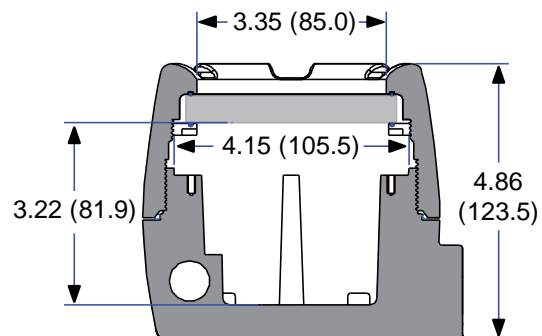

Figure 2. Enclosure Dimensions – Side Cross Section View



Download free 3-D CAD files of these instruments to simplify your drawings!

predig.com/documentation-cad

Cover Jam Screw

The cover jam screw should be properly installed once the meter has been wired and tested in a safe environment. The cover jam screw is intended to prevent the removal of the meter cover in a flameproof environment without the use of tools. Using a M2 hex wrench, turn the screw clockwise until the screw contacts the meter. Turn the screw an additional 1/4 to 1/2 turn to secure the cover. Caution: Excess torque may damage the threads and/or wrench.

Connections

To access the connectors, remove the enclosure cover and unscrew the two captive screws that fasten the display module. Disconnect the ribbon cable and remove the display module. Signal connections are made to a four-terminal connector in the base of the enclosure. Grounding connections are made to the two ground screws provided on the base – one internal and one external.

SIGNAL +	4-20 mA signal input positive terminal connection
SIGNAL -	4-20 mA signal return/negative terminal connection when not using loop powered backlight.
BACKLIGHT +	+9-36 VDC when powering backlight from external supply.
BACKLIGHT -	4-20 mA signal return/negative terminal when using the installed loop powered backlight or ground/negative when powering backlight from external supply.

Refer to *Figure 3* for terminal positions.

⚠ WARNINGS

- Observe all safety regulations. Electrical wiring should be performed in accordance with all agency requirements and applicable national, state, and local codes to prevent damage to the meter and ensure personnel safety.
- Static electricity can damage sensitive components.
- Observe safe handling precautions for static-sensitive components.
- Use proper grounding procedures/codes.
- If the meter is installed in a high voltage environment and a fault or installation error occurs, high voltage may be present on any lead or terminal.

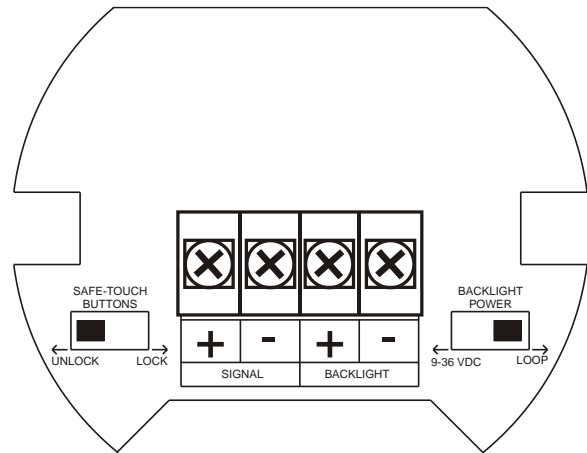

Figure 3. Connector Board

Wiring Diagrams

Signal connections are made to a four-terminal connector mounted in the base of the enclosure per *Figure 3. Connector Board*. The enclosure also provides one internal and one external earth grounding screw.

For installations that don't use the backlight, the maximum voltage drop is 3 V and connections are made per *Figure 4*.

For installations that use the backlight powered from the meter, the maximum voltage drop is 6 V and connections are made per *Figure 5*.

For installations that use the backlight powered from an external source, the maximum voltage drop is 3 V and connections are made per *Figure 6*.

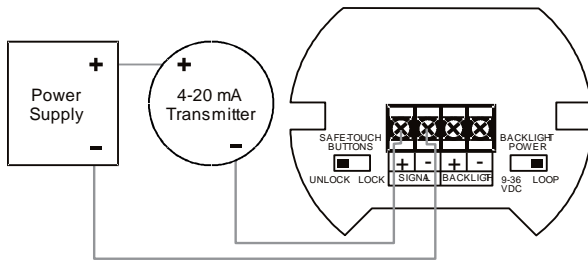

Figure 4. Connections without Backlight

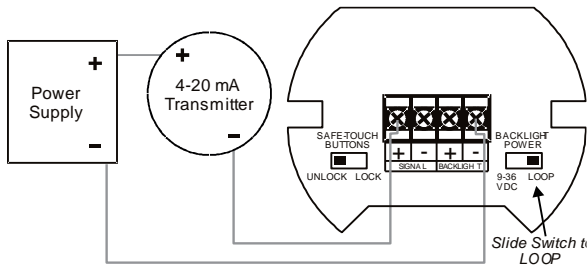

Figure 5. Connections with Loop-Powered Backlight

Loop-powered backlight brightness will increase as the input signal current increases. If constant backlight brightness is desired, the backlight should be powered by an external source.

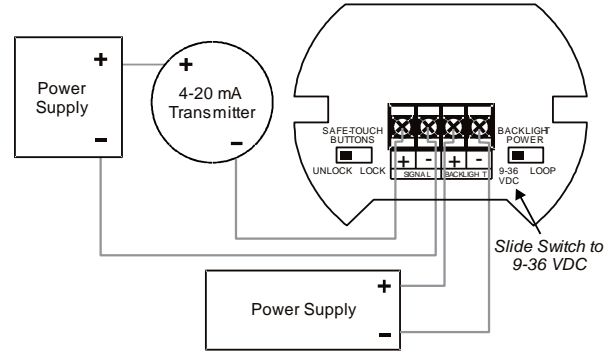

Figure 6. Connections with Externally-Powered Backlight

It is possible to use the same transmitter (signal loop) power supply for the externally powered backlight. The backlight circuit will draw 25 mA in addition to the loop circuit.

Setup and Programming

There is **no need to recalibrate** the meter for milliamps when first received from the factory.

The meter is **factory calibrated** for milliamps prior to shipment. The calibration equipment is traceable to NIST standards.

Overview

Setup and programming is done through the infrared through-glass SafeTouch buttons or using the mechanical buttons when uncovered. There are two slide switches located on the connector board. One is used to select backlight power and the other is to lock or unlock the SafeTouch Buttons.

After all connections have been completed and verified, connect the ribbon cable to the display module, fasten the display module to the base, install enclosure cover, and then apply power.

SafeTouch Buttons

The PD6800 is equipped with four sensors that operate as through-glass buttons so that it can be programmed and operated without removing the cover (and exposing the electronics) in a hazardous area. These buttons can be disabled for security by selecting the LOCK setting on the switch located on the connector board in the base of the enclosure. To actuate a button, press one finger to the glass directly over the marked button area. When the cover is removed, the four mechanical buttons located next to the sensors are used. The sensors are disabled when a mechanical button is pressed and will automatically be re-enabled after 60 seconds of inactivity.

SafeTouch Button Tips and Troubleshooting

The SafeTouch buttons are designed to filter normal levels of ambient interference and to protect against false triggering, however, it is recommended that the SafeTouch buttons be disabled (slide switch to LOCK) if there is an infrared interference source in line-of-sight to the display.

SafeTouch Button Tips:

- To remove cover with power applied (safe area only), or to clean the window, select **SERVICE** in the main menu before opening the cover. This will temporarily disable the SafeTouch buttons for 60 seconds to prevent inadvertent use. Use the mechanical buttons while the meter is open.
- To the extent possible, install the display facing away from sunlight, windows, reflective objects and any sources of infrared interference.
- Keep the glass window clean.
- Tighten the cover securely.
- Use a password to prevent tampering.

After all connections have been completed and verified, apply power to the loop.

IMPORTANT

- SafeTouch buttons will not work if two or more buttons are detected as being pressed simultaneously. As a result, be careful to avoid triggering multiple buttons or reaching across one button location to press another.

Buttons and Display

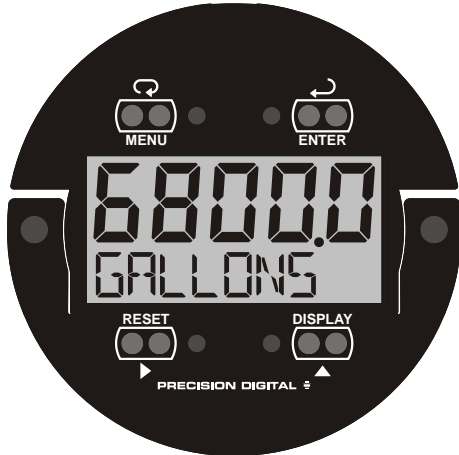

Button Symbol	Description
	Menu
	Right arrow/Reset
	Up arrow/Display
	Enter

Symbol	Status
HI	High Alarm Set
LO	Low Alarm Set
	Password Enabled

Menu Button

- Press the **Menu** button to enter or exit the Programming Mode at any time.
- Press and hold the **Menu** button for five seconds to access the *Advanced* features of the meter.

Right / Reset Button

- Press the **Right** arrow button to move to the next digit or decimal position during programming.

Up / Display Button

- Press the **Up** arrow button to scroll through the menus, decimal point, or to increment the value of a digit.

Enter Button

- Press the **Enter** button to access a menu or to accept a setting.

The meter displays various functions and messages during setup, programming, and operation. The following table shows the main menu functions and messages in the order they appear in the menu.

Main Menu Display Functions & Messages

The meter displays various functions and messages during setup, programming, and operation. The following table shows the main menu functions and messages in the order they appear in the menu.

Display	Parameter	Action/Setting
SETUP	Setup	Enter Setup menu
dECPt	Decimal point	Enter Decimal Point menu
PrOG	Program	Enter the Program menu
SCALE	Scale	Enter the Scale menu
CAL	Calibrate	Enter the Calibrate menu
INPt 1	Input 1	Calibrate input 1 signal or program input 1 value
dSPL 1	Display 1	Program display 1 value
INPt 2	Input 2	Calibrate input 2 signal or program input 2 value
dSPL 2	Display 2	Program display 2 value
SPAN Error	Span Error	Error, calibration not successful, check signal
TAG	Tag/Units	Enter the Tag/Units Menu
On	Tag On	Enable Tag/Units
OFF	Tag Off	Disable Tag/Units
PASSWORD	Password	Enter the Password menu
UNLOCKED	Unlocked	Program password to lock meter
LOCKED	Locked	Enter password to unlock meter
99999 -99999	Flashing display	Overrange condition Underrange condition
SERVICE	Service	Select before removing/installing cover for service or to clean the glass window

Main Menu

The main menu consists of the most commonly used functions: *Setup*, *Password*, and *Service*.

Press **MENU** button to enter Programming Mode then press the **Up Arrow** button to scroll through the main menu.

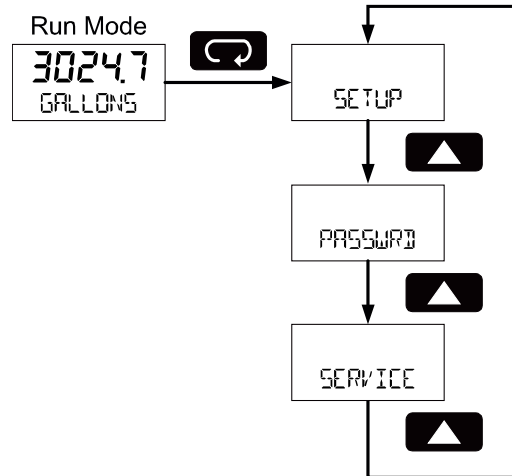

- Press **MENU**, at any time, to exit and return to Run Mode. Changes made to settings prior to pressing **Enter** are not saved.
- Changes to the settings are saved to memory only after pressing **Enter**.
- The display moves to the next menu every time a setting is accepted by pressing **Enter**.

Setting Up the Meter (SETUP)

Press the **Enter** button to access any menu or press **Up** arrow button to scroll through choices. Press the **Menu** button to exit at any time.

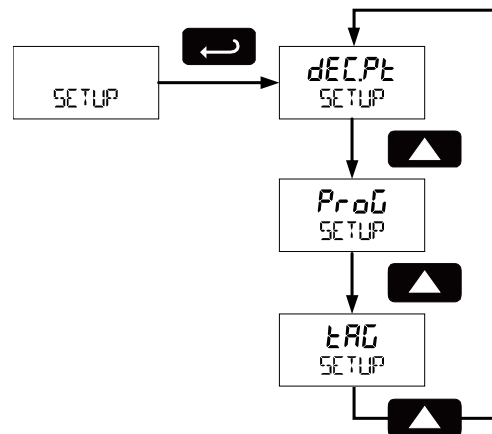

Setting Numeric Values

The numeric values are set using the **Right** and **Up** arrow buttons. Press **Right** arrow to select next digit and **Up** arrow to increment digit.

The digit being changed blinks.

Press the **Enter** button, at any time, to accept a setting or **MENU** button to exit without saving changes.

The decimal point is set using the **Right** or **Up** arrow button in the *Setup-decimal point* menu.

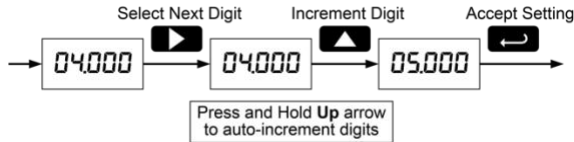

Setting the Decimal Point (dEc.Pt)

Decimal point may be set with up to four decimal places or with no decimal point.

Pressing the **Right** arrow moves the decimal point one place to the right until no decimal point is displayed. Pressing the **Up** arrow moves the decimal point one place to the left.

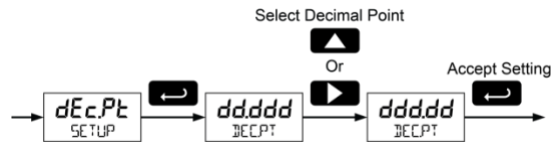

Programming the Meter (PrOg)

The meter may either be scaled (SCALE) without applying an input or calibrated (CAL) by applying an input. The meter comes factory calibrated to NIST standards, so for initial setup, it is recommended to use the (SCALE) function. The Program menu contains the Scale (SCALE) and the Calibrate (CAL) menus. Process inputs may be scaled or calibrated to any display within the range of the meter.

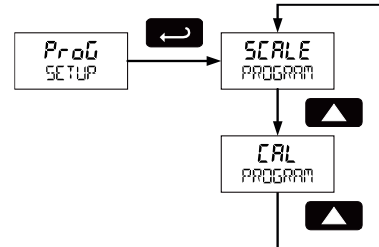

Note: The Scale and Calibrate functions are exclusive of each other. The meter uses the last function programmed. Only one of these methods can be employed at a time. The Scale and Calibrate functions can use up to 32 points (default is 2). The number of points should be set in the Advanced Features menu under the Multi-Point Linearization (LINEAR) menu selection on page 19 prior to scaling and calibration of the meter, see Advanced Features Menu, page 18.

Scaling the Meter (SCALE)

The 4-20 mA input can be scaled to display the process in engineering units.

A signal source is not needed to scale the meter; simply program the inputs and corresponding display values.

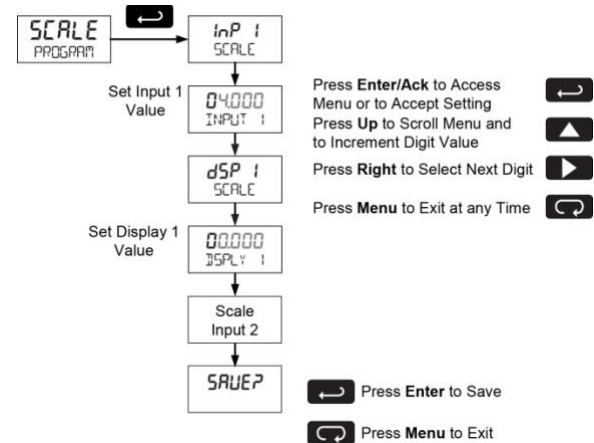

For instructions on how to program numeric values see *Setting Numeric Values*, page 14.

Calibrating the Meter (cRL)

To scale the meter without a signal source refer to *Scaling the Meter (sCRL)* on page 15.

The meter can be calibrated to display the process in engineering units by applying the appropriate input signal and following the calibration procedure. The use of a calibrated signal source is strongly recommended.

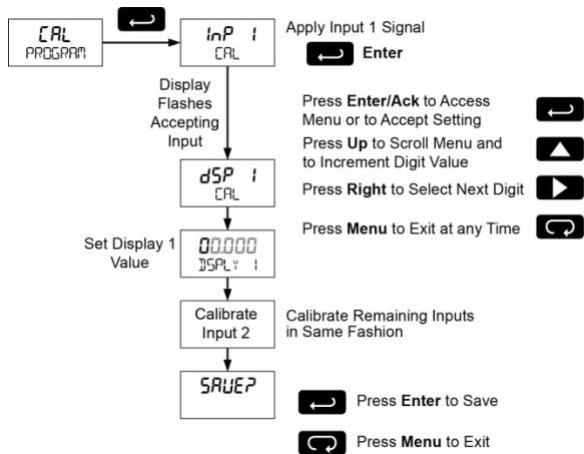

1. Press the **Up** arrow button to scroll to the *Calibration* menu (cRL) and press **Enter**.
2. The meter displays *InP 1*. Apply a known signal and press **Enter**. The display will flash while accepting the signal.
3. After the signal is accepted, the meter displays *d5PL 1*. Press **Enter**. Enter a corresponding display value for the signal input, and press **Enter** to accept.
4. The meter displays *InP 2*. Apply a known signal and press **Enter**. The display will flash while accepting the signal.
5. After the signal is accepted, the meter displays *d5PL 2*. Press **Enter**. Enter a corresponding display value for the signal input and press **Enter** to accept.

After completing calibration the *SRUEP* display will need to be acknowledged using the Enter key before calibration will take effect.

Minimum Input Span

The minimum input span is the minimum difference between input 1 and input 2 signals required to complete the calibration or scaling of the meter. The minimum span is 0.10 mA.

If the minimum span is not maintained, the meter reverts to input 2, allowing the appropriate input signals to be applied.

Re-Calibrating the Internal Calibration Reference (iCRL)

The *Internal Calibration (iCRL)* menu, located in the *Advanced* features menu, is used to recalibrate the internal calibration reference. Recalibration is recommended at least every twelve months. Refer to *Internal Calibration (iCRL)*, page 21 for instructions.

Setting the Tag Display (tRG)

The meter can be set to display a combination of seven alphanumeric characters for engineering units (e.g. GALLONS) or for identification (e.g. TANK 3). Press **Right** arrow to select next unit and **Up** arrow to increment unit.

The unit being changed blinks.

Press the **Enter** button, at any time, to accept a setting or **Menu** button to exit without saving changes. Press and hold **Up** arrow to auto-scroll characters.

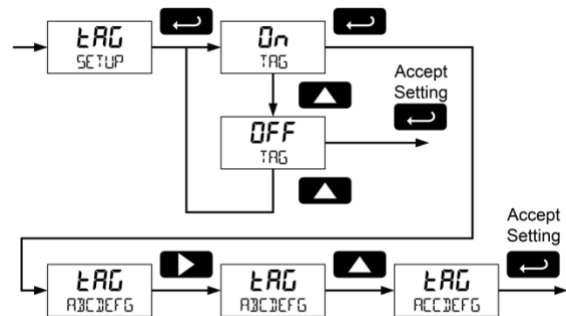

Setting Up the Password (PASSWORD)

The *Password* menu is used to program a five-digit password to prevent unauthorized changes to the programmed parameter settings. The lock symbol is displayed to indicate that settings are protected.

Locking the Meter

Enter the *Password* menu and program a five-digit password.

For instructions on how to program numeric values see *Setting Numeric Values*, page 2.



Setting Up the Meter (SETUP)

Press the **Enter** button to access any menu or press **Up** arrow button to scroll through choices. Press the **Menu** button to exit at any time.

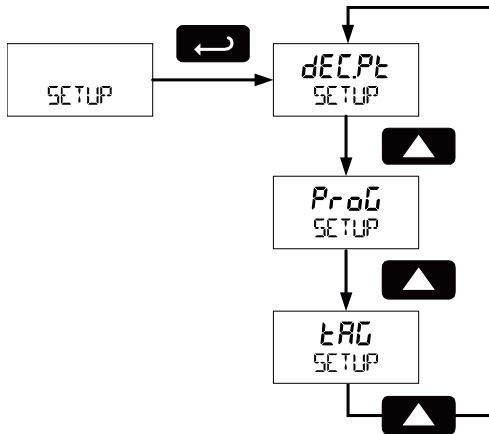

Record the password for future reference. If appropriate, it may be recorded in the space provided.

Model:	
Serial Number:	
Password:	__ __ __ __ __

Additional parameters, not needed for most applications, are programmed with the *Advanced Features* menu; see the *Advanced Features Menu* on page 18.

Making Changes to a Password Protected Meter

If the meter is password protected, the meter will display the message **LOCKED** when the Menu button is pressed. Press the Enter button while the message is being displayed and enter the correct password to gain access to the menu. After exiting the programming mode, the meter returns to its password protected condition.

Disabling Password Protection

To disable the password protection, access the *Password* menu and enter the correct password twice, as shown below. The meter is now unprotected until a new password is entered.

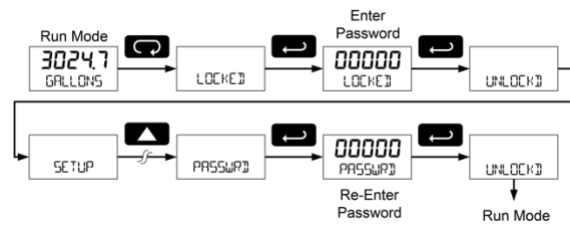

If the correct five-digit password is entered, the meter displays the message **UNLOCK** (*unlocked*) and the protection is disabled until a new password is programmed.

If the password entered is incorrect, the meter displays the message **LOCKED** for about two seconds, and then it returns to Run Mode. To try again, press Enter while the *Locked* message is displayed.

Did you forget the password?

The password may be disabled by entering a master password. If you are authorized to make changes, enter the master password 50865 to unlock the meter.

Service Feature (SERVICE)

Select *SERVICE* from the main menu to temporarily disable the SafeTouch buttons to prevent inadvertent use. Buttons will automatically resume operation after 60 seconds. The display blinks the message *SERVICE* during this period. This should be used when cleaning the window and when installing or removing the cover while power is applied (in a safe area only).

The service menu is not shown when the Safe Touch buttons are disabled using the slide switch located on the connector board.

Advanced Features Menu

To simplify the setup process, functions not needed for most applications are located in the *Advanced Features* menu. Press and hold the **MENU** button for five seconds to access the *Advanced* features menu.

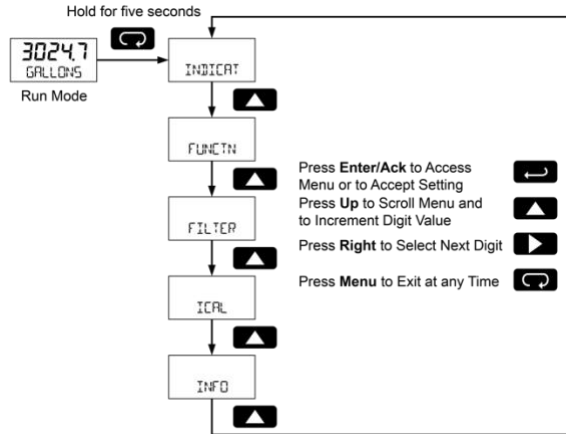

Advanced Features Menu & Display Messages

The following table shows the *Advanced* features menu functions and messages in the order they appear in the menu.

Display	Parameter	Action/Setting
INDICAT	<i>Indicate</i>	Enter Indication (Alarm) menu
OFF	<i>Off</i>	Disable alarm
ALARM	<i>Alarm</i>	Enter alarm indication menu
SET	<i>Set Point</i>	Program set point
RESET	<i>Reset Point</i>	Program reset point
FUNCT	<i>Function</i>	Enter advanced function menu
LINEAR	<i>Linear</i>	Set linear scaling
SQR	<i>Square Root</i>	Set square root extraction
PROG	<i>Programmable Exponent</i>	Set programmable exponent
CUTOFF	<i>Low-Flow Cutoff</i>	Set low-flow cutoff
FILTER	<i>Filter</i>	Set noise filter
OFF	<i>Filter Off</i>	Disable noise filter
LO	<i>Filter Low</i>	Set noise filter to low setting
MED	<i>Filter Medium</i>	Set noise filter to medium setting
H I	<i>Filter High</i>	Set noise filter to high setting
ICAL	<i>Internal Calibration</i>	Enter internal reference calibration
INFO	<i>Meter Information</i>	Show software number and version, or reset to factory defaults
SW	<i>Software</i>	Software number
VER	<i>Software Version</i>	Software version
RESET DEFAULTS	<i>Reset Defaults</i>	Restore factory default parameter settings

Indication (INDICAT)

The *Indication* menu is used to enable and set up a high or low alarm indication on the screen. When alarm indication is enabled, the HI and LO symbols are used accompanied by a flashing display.

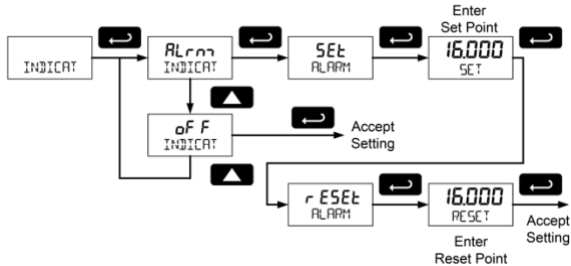

Alarm (ALARM)

- **High alarm trip point:** program set point above reset point.
- **Low alarm trip point:** program set point below reset point.
- Alarm deadband is determined by the difference between set and reset points. Minimum deadband is one display count. If set and reset points are programmed the same, output will reset one count below set point.

To acknowledge the alarm, press the **Enter** button once for acknowledge prompt and a second time to confirm.

Advanced Function Selection (FUNCTN)

The *Advanced Function* menu is used to select the advanced function to be applied to the input: linear, square root, or programmable exponent. The multi-point linearization is part of the linear function selection.

Meters are set up at the factory for linear function with 2-point linearization. The linear function provides a display that is linear with respect to the input signal.

Multi-Point Linearization (LINEAR)

Up to 32 linearization points can be selected under the *Linear* function. The multi-point linearization can be used to linearize the display for non-linear signals such as those from level transmitters used to measure volume in odd-shaped tanks or to convert level to flow using weirs and flumes that require a complex exponent. These points are established via direct entry (SCALE) or with a live calibration signal source (CAL).

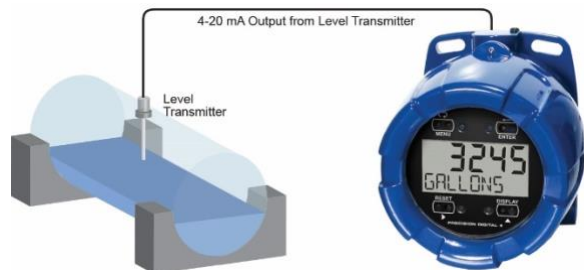
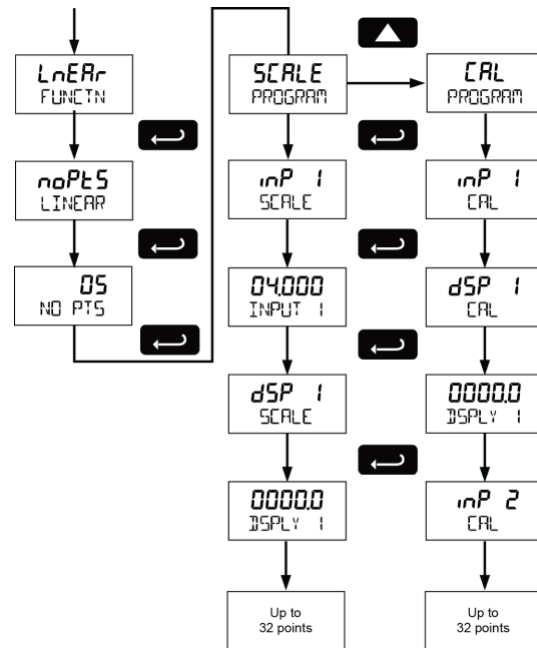

PD6800 Displaying Volume in Round Horizontal Tank Using Multi-Point Linearization Feature

Multi-Point Scaling (SCALE)

The multi-point scaling is entered after selecting the number of points (numpoints). The input signal levels (input 1-32) for up to 32 points, along with the corresponding meter reading (display 1-32) should be entered for each linearization point.

Multi-Point Calibration (CAL)

The meter can be calibrated using a current source instead of using input scaling. This process will override previously programmed scaling points. Apply a live signal using a known accurate signal source (input 1-32) and then enter the corresponding meter reading (display 1-32) for that input signal level.

The use of a calibrated signal source is strongly recommended.

▲ IMPORTANT

- After entering the last display value, the linearization entries must be saved (SAVE) before they are put into effect. However, you may move past this selection using the Up arrow key if you need to go back and correct and earlier entry. Once confident in the entries, you must navigate back to the Save menu screen (SAVE) and press the Enter key to save the changes.

Square Root Linearization (SQUR)

The square root function can be used to linearize the signal from a differential pressure transmitter and display flow rate in engineering units.



PD6800 Displaying Flow Rate by Extracting Square Root from DP Transmitter Signal.

Low-Flow Cutoff (CUTOFF)

The low-flow cutoff feature allows the meter to be programmed so that the often-unsteady output from a differential pressure transmitter, at low flow rates, always displays zero on the meter. The default cutoff is zero to prevent negative readings, but this may be overridden to allow them.

The cutoff value may be programmed from 0 to 99999. Below the cutoff value, the meter will display zero. Selecting either square root or programmable exponent will set the cutoff value to 0. Program the cutoff value to 0 to disable.

Programmable Exponent Linearization (PrOUE)

The programmable exponent can be used to linearize the signal from level transmitters in open-channel flow applications using weirs and flumes.

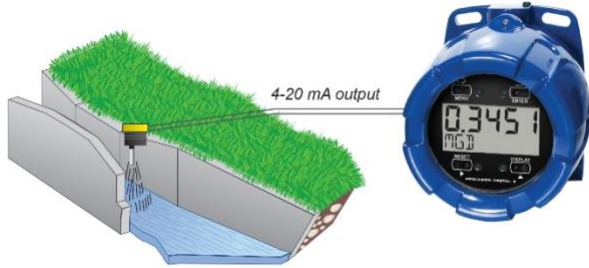

The PD6800, in combination with an ultrasonic level transmitter, makes for an economical way to measure and display open channel flow rate in most weirs and flumes. A guide such as the ISCO Open Channel Flow Measurement Handbook can provide the user with all the information needed: the exponent used in the flow equation for the desired flow units and the flow rate for any given head height. For example, to display the open channel flow rate from a 3" Parshall flume, the ISCO handbook advises the exponent is 1.547 and at the maximum head height of 3.0 feet, the flow rate is 3.508 MGD.

3" Parshall Flume Discharge Table

Formula: CFS = 0.9920 H^{1.547}
 GPM = 445.2 H^{1.547}
 MGD = 0.6411 H^{1.547}
 Where: H = Head in feet

Table 12-3

Head (Feet)	CFS	GPM	MGD
3.00	5.428	2436	3.508

ISCO Open Channel Flow Measurement Handbook, 3rd edition

With this information the PD6800 should be programmed in the following fashion. This setup assumes the level transmitter is programmed to output 20 mA at the maximum head height of 1.10 feet; but any mA value at a head height with a known flow rate may be used.

Function	Desired	Programming
Open Channel Flow	3" Parshall flume	Set Programmable Exponent to 1.547
Flow Rate	Millions of Gallons per Day (MGD)	Set 4 mA = 0 20 mA = 3.508
Display	Display Flow Rate	Set upper display for flow rate display and lower display units/tag for MGD.

To display both flow rate and total, consider Precision Digital's [Model PD6820 Flow Rate Totalizer](#).

Input Signal Filter (FILTER)

The noise filter is available for unusually noisy signals that cause an unstable process variable display. The noise filter averages the input signal over a certain period. The filter level can be set to low (L), medium (Med), high (H), or off (OFF). The higher the filter setting, the longer the averaging time and so the longer the display may take to find its final value. The filter contains a noise filter bypass feature so that while small variations in the signal will be filtered out, large, abrupt changes to the input signal are displayed immediately.

Internal Calibration (ICAL)

There is **no need to recalibrate** the meter for milliamps when first received from the factory. The meter is **factory calibrated** for milliamps prior to shipment. The calibration equipment is traceable to NIST standards.

The internal calibration allows the user to scale the meter without applying a signal. The use of a calibrated signal source is necessary to perform the internal calibration of the meter. Check calibration of the meter at least every 12 months.

Notes:
 The signal source must have a full-scale accuracy of 0.002% or better between 4 and 20 mA in order to maintain the specified accuracy of the meter.
 Allow the meter to warm up for at least 15 minutes before performing the internal calibration procedure.

The *Internal calibration* menu is part of the *Advanced features* menu.

Press and hold the **MENU** button for 5 seconds to enter the *Advanced features* menu. Press the **Up** arrow button to scroll to the *Internal Calibration* menu (ICAL) and press **Enter**.

Error Message (SPAn ERROR)

An error message indicates that the calibration process was not successful. After the error message is displayed, the meter will revert to input 2 calibration settings. The error message might be caused by inadvertently leaving the signal at the previous level or not maintaining the minimum span. Press the Menu button to cancel the current calibration process if necessary.

Information (INFO)

The *Internal calibration* menu is part of the *Advanced features* menu. It shows software identification number and version number. To determine the software version of a meter:





Go to the *Information* menu (INFO) and press **Enter** button.

Continue pressing **Enter** to scroll through the software release number and software version.

Following the information display, the meter will exit the *Advanced features* menu and return to run mode.

Operation

Front Panel Buttons Operation

Button Symbol	Description
	Press to enter or exit Programming Mode or exit Max/Min readings
	Press to reset Max/Min readings
	Press to display Max/Min readings alternately
	Press to display Max or Min reading indefinitely while displaying Max or Min

The meter displays 4000 mA. Apply a 4.000 mA signal and press **Enter**. The display flashes for a moment while the meter is accepting the signal.

After the signal is accepted, the meter displays 20000 mA. Apply a 20.000 mA signal and press **Enter**. The display flashes for a moment while the meter is accepting the signal.

Maximum & Minimum Readings (MAXIMUM & MINIMUM)

The maximum and minimum (peak & valley) readings reached by the process are stored in the meter since the last reset or power-up. The meter shows MAXIMUM or MINIMUM to differentiate between run mode and max/min display. Press **Enter** to remain in Max/Min display mode. If **Enter** is not pressed, the Max/Min display readings will time out after ten seconds. The meter will return to display the actual reading.

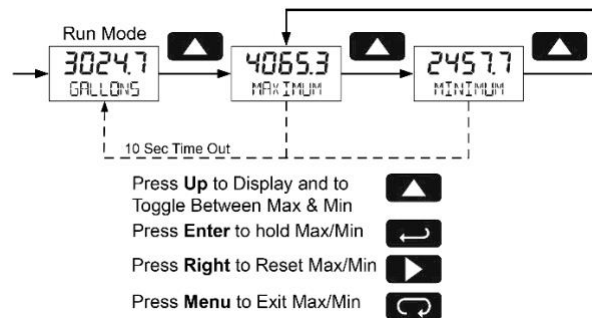

Reset Meter to Factory Defaults

When the parameters have been changed in a way that is difficult to determine what's happening, it might be better to start the setup process from the factory defaults.

Instructions to load factory defaults:

Enter the *Advanced* features menu.

Press and hold **Reset** button when INFO is shown.

Press **Enter** when rESEt DEFALTSP prompt is shown

Note: If **Enter** is not pressed within three seconds, the prompt will stop flashing return to showing INFO.

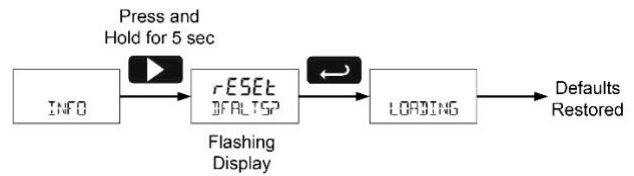

Factory Defaults & User Settings

The following table shows the factory setting for most of the programmable parameters on the meter. Next to the factory setting, the user may record the new setting for the particular application.

Model: _____

S/N: _____

Date: _____

Parameter	Display	Default Setting	User Setting
Programming	PrOG	Scale	
Input 1	INPt 1	4.000 mA	
Display 1	dSPt 1	4.000	
Input 2	INPt 2	20.00 mA	
Display 2	dSPt 2	20.000	
Decimal point	ddddd	3 places	
Tag	tAG	Off	
Password	PASSwRD	00000 (unlocked)	
Advanced Features			
Indicate	INDICAT	Off	
Function	FUNCTN	Linear	
Cutoff	CUTOFF	0 (disabled)	
Filter	FILTER	Low	

Troubleshooting

Due to the many features and functions of the meter, it's possible that the setup of the meter does not agree with what an operator expects to see. If the meter is not working as expected, refer to the *Diagnostics* menu and consult the recommendations described below.

Troubleshooting Tips

Symptom	Check/Action
No display or faint display	Check input signal connections. Perform hard reset by shorting S+ and S- terminals.
Rate display unsteady	Increase filter setting in <i>Advanced</i> menu.
Meter displays error message during calibration (<i>SPAN ERROR</i>)	Check signal connections. Verify minimum input span requirements.
Meter flashes 99999 or -9999	Check input signal is within scaled range of 99999 and -9999.
Display stuck displaying <i>MAXIMUM</i> or <i>MINIMUM</i>	Press Menu to exit Max/Min display readings.
Display response is too slow	Check filter setting to see if it can be lowered to <i>LO</i> or <i>OFF</i> .
If the display locks up or the meter does not respond at all	Perform hard reset by shorting S+ and S- terminals.
Backlight does not appear.	Backlight is intended for viewing assistance in dim lighting conditions. It may not be noticeable under good lighting conditions. Check connections as shown in <i>Figure 5. Connections with Loop-Powered Backlight</i> or <i>Figure 6. Connections with Externally-Powered Backlight</i> on page 11.
SafeTouch buttons do not respond	Service menu was selected, or mechanical button was pushed. The SafeTouch buttons will be re-enabled automatically 60 seconds after the last button push. If slide switch on connector board is in Lock position, switch to Unlock. Sunlight can interfere with the sensors. It is recommended to shield the window from sunlight while operating the buttons by standing so as to block direct sunlight.
Other symptoms not described above	Call Technical Support for assistance.

Quick User Interface Reference

Pushbutton	Function
MENU	Go to programming mode or leave programming. Hold for 5 seconds to enter <i>Advanced Features</i> menu directly.
RIGHT Arrow	Move to next digit. Go to previous menu or alphanumeric character selection. Reset max or min while displayed.
UP Arrow	Move to next selection or increment digit. Cycle through maximum, minimum, and mA display mode.
ENTER	Accept selection/value and move to next selection. Acknowledge alarms.

To enter the Advanced Features Menu, hold the **Menu** button for 5 seconds.

Max/Min Mode

While in Run Mode, pressing **Up** Arrow will initiate MAX/MIN Mode. **Up** Arrow toggles between MAX & MIN displays, and **Right** Arrow resets the MAX/MIN to the current value. Press **Menu** or wait 10 seconds to return to Run Mode. Pressing **Enter/Ack** will disable the 10 second timeout and continuously display Max or Min.

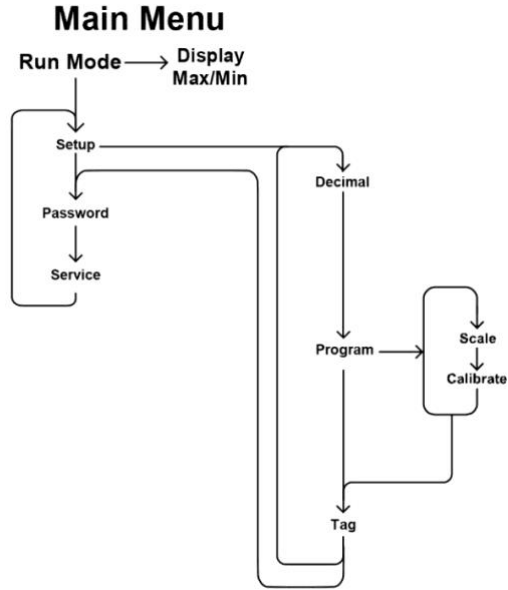
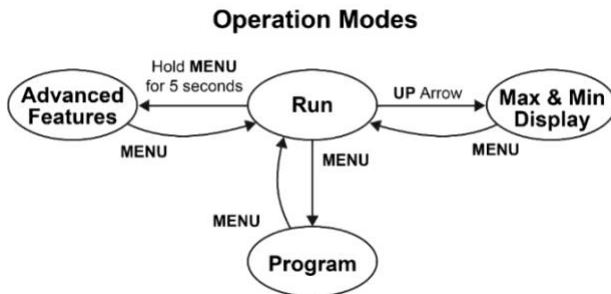

Advanced Menu

Press & hold **Menu** for 5 seconds

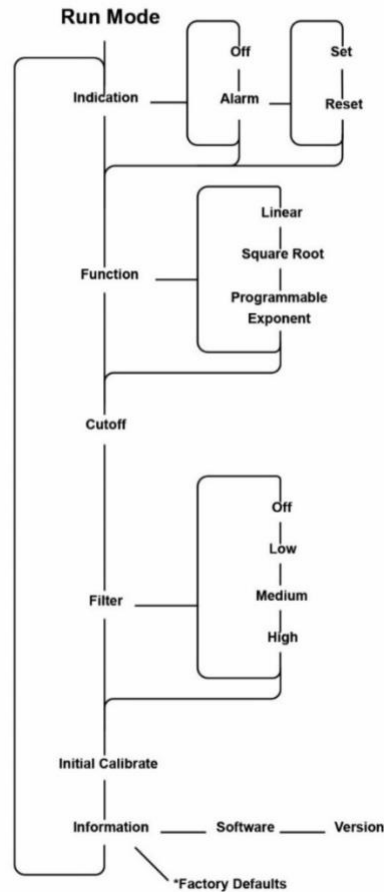

*Access by holding **Right/Reset** for 3 seconds

Contact Precision Digital

Technical Support

Call: (800) 610-5239 or (508) 655-7300

Fax: (508) 655-8990

Email: support@predig.com

Sales Support

Call: (800) 343-1001 or (508) 655-7300

Fax: (508) 655-8990

Email: sales@predig.com

Place Orders

Email: orders@predig.com

For the latest version of this manual please visit

www.predig.com

PRECISION DIGITAL CORPORATION

233 South Street • Hopkinton MA 01748 USA
Tel (800) 343-1001 • Fax (508) 655-8990

www.predig.com

