

PD6801 Explosion-Proof Loop-Powered Feet & Inches Level Meter

Instruction Manual



- Fully-Approved Explosion-Proof Loop-Powered Meter
- 4-20 mA Input with $\pm 0.03\%$ Accuracy
- 3.0 Volt Drop (6.0 Volt Drop with Backlight)
- Easy Field Scaling in Engineering Units without Applying an Input
- 0.6" (15.2 mm) Feet & Inches Upper Display With 1/8 or 1/16 Resolution
- 0.4" (10.2 mm) 7 Alphanumeric Characters Lower Display for Tag, Volume, or Percent
- Display Level in Feet & Inches and Volume, Percent or Decimal Height Simultaneously
- Display Mountable at 0°, 90°, 180°, & 270°
- SafeTouch™ Through-Glass Button Programming
- 20-Segment Tank Side Level Indicator Bargraph
- Open Collector Output Assignable to High or Low Alarm
- HART® Protocol Transparent
- Loop or External DC-Powered Backlight Standard
- Operating Temperature Range: -40 to 75°C (-40 to 167°F)
- FM Approved as Explosion-Proof / Dust-Ignition Proof / Flame-Proof
- CSA Certified as Explosion-Proof / Dust-Ignition Proof / Flame-Proof
- ATEX and IECEx Certified as Flame-Proof and Protection by Enclosure
- Conformal Coated PCBs for Dust and Humidity Protection
- Password Protection
- 32-Point Linearization
- Wide Viewing Angle
- Flanges for Wall or Pipe Mounting
- Explosion-Proof, IP68, NEMA 4X Die-Cast Aluminum Enclosure
- Two 3/4" NPT Threaded Conduit Openings (One Plug Installed)
- 2" U-Bolt Kits Available
- 3-Year Warranty

PRECISION DIGITAL CORPORATION

233 South Street • Hopkinton MA 01748 USA
Tel (800) 343-1001 • Fax (508) 655-8990

www.predig.com

**PRECISION
DIGITAL**

Disclaimer

The information contained in this document is subject to change without notice. Precision Digital Corporation makes no representations or warranties with respect to the contents hereof; and specifically disclaims any implied warranties of merchantability or fitness for a particular purpose.

CAUTION

- Read complete instructions prior to installation and operation of the meter.

WARNINGS

- Risk of electric shock or personal injury.
- This product is not recommended for life support applications or applications where malfunctioning could result in personal injury or property loss. Anyone using this product for such applications does so at his/her own risk. Precision Digital Corporation shall not be held liable for damages resulting from such improper use.
- Failure to follow installation guidelines could result in death or serious injury. Make sure only qualified personnel perform the installation.
- Never remove the meter cover in explosive environments when the circuit is live.
- Cover must be fully engaged to meet flameproof/explosion-proof requirements.

WARNING

Cancer and Reproductive Harm - www.P65Warnings.ca.gov

Limited Warranty

Precision Digital Corporation warrants this product against defects in material or workmanship for the specified period under "Specifications" from the date of shipment from the factory. Precision Digital's liability under this limited warranty shall not exceed the purchase value, repair, or replacement of the defective unit. See Warranty Information and Terms & Conditions on www.prediq.com for complete details.

© 2022 Precision Digital Corporation. All rights reserved.

Introduction

The ProtEX-F&I PD6801 is a rugged, explosion-proof loop-powered indicator specifically designed for level applications in hazardous areas or in the harshest environmental conditions. The meter displays level in easy to read and understand feet, inches, and fractions of an inch; and a 20-segment tank level indicator. The lower display can show a custom unit or tag, percent full, or a second scale for the 4-20 mA input used to indicate volume.

The meter derives all of its power from the 4-20 mA loop. It is programmed using the four SafeTouch through-glass buttons, without removing the cover, and can be scaled with or without a calibration signal. The upper display will read up to 699 ft. – 11 ¹⁵/₁₆ inches. The alphanumeric volume/tag display will read up to 9,999,999. The alphanumeric display can also be programmed to show any combination of numbers and letters up to seven characters long for use as engineering units and/or the process identification tag. The backlight lets you see the display under any lighting condition and can be powered from either the 4-20 mA loop or from a separate DC power supply.

The enclosure is provided with two threaded conduit holes and integrated pipe or wall mounting slotted flanges.

Ordering Information

Model	Description
PD6801-0K1	Explosion-Proof Loop-Powered Feet & Inches Level Meter with backlight

Accessories

Model	Description
PDA0001	3/4" M-NPT to F-M20 Reducer
PDA0002	3/4" M-NPT to 1/2" F-NPT Reducer
PDA1024-01	24 VDC Power Supply for DIN Rail
PDA6846	Steel 2" U-Bolt Kit. All Material: Zinc Plated Steel; (1) U-Bolt for 2" Pipe with (2 each) Washers, Lock Washers, and Nuts.
PDA6846-SS	Stainless Steel 2" U-Bolt Kit. All Material: Stainless Steel; (1) U-Bolt for 2" Pipe with (2 each) Washers, Lock Washers, and Nuts.
PDA-SSTAG	Custom Stainless Steel Tag (see website for convenient ordering form)

Helpful Videos

The following videos might be of interest.

ProtEX-F&I Loop-Powered Level Meter

The PD6801 level meter displays level in feet and inches, providing simple and easy-to-understand level indication.



<https://www.predig.com/videos/AkWDnB-XI9k>

ProtEX Explosion-Proof Meter Introduction

Learn about all the meters in the ProteX Series.



https://www.predig.com/videos/rJsvL_8PEyc

ProtEX Approvals Overview

The ProtEX Series carries extensive international approvals for hazardous areas.



<https://www.predig.com/videos/CTsNXQeRqTA>

ProtEX Enclosure Unique Features

Learn about the unique features of the ProtEX Series enclosures.



<https://www.predig.com/videos/SwWKJ3L8ibo>

Introduction to ProtEX SafeTouch Programming

Through-glass buttons make programming easy without removing the enclosure's cover.



https://www.predig.com/videos/SafeTouch_Buttons

Vantageview Series Introduction

This series designed for use in safe areas delivers the same functionality of the ProtEX Series in a rugged plastic enclosure.



https://www.predig.com/videos/OC_trhGqTtWU

Table of Contents

Introduction	2
Ordering Information	2
Table of Contents.....	4
Specifications.....	6
General	6
Input.....	6
Open Collector Output.....	6
Product Ratings and Approvals	7
Electromagnetic Compatibility	7
EU Declaration of Conformity	8
Safety Information	8
Installation	9
Unpacking	9
Pre-Installed Conduit Plug.....	9
Mounting	9
Dimensions	9
Cover Jam Screw.....	10
Connections.....	10
Wiring Diagrams	11
External Acknowledge Connection.....	11
Open Collector Output Connections.....	11
Setup and Programming	12
Overview.....	12
SafeTouch Buttons.....	12
SafeTouch Button Operation.....	12
SafeTouch Button Tips and Troubleshooting.....	12
Buttons and Display	13
Main Menu Display Functions & Messages	14
Main Menu	14
Setting Up the Meter (SETUP)	15
Setting Numeric Values.....	15
Scaling the Meter (SCALE)	16
Selecting Inch Fraction Display Mode (FRACTN).....	16
Scaling the Tank Level Indicator (PERCENT).....	16
Configuring the Lower Display (DISPLAY)	17
Setting the Tag (TAG).....	17
Advanced Features Menu (ADVANCE).....	18
Advanced Features Menu & Display Messages.....	18
Alarm Output (OUTPUT)	19
Input Signal Filter (FILTER)	19
Volume Display Scaling (VOLSCALE)	19
Level Input Live Signal Calibration (LVL CAL).....	20
Internal Calibration (ICAL).....	20
Level Input Multipoint Linearization (MULTIPT).....	20
Information (INFO).....	20
Setting Up the Password (PASSWORD).....	21
Locking the Meter.....	21
Making Changes to a Password Protected Meter	21
Disabling Password Protection.....	21
Operation	22
Front Panel Buttons Operation	22
Display Maximum, Minimum, and Input Current	22
Reset Meter to Factory Defaults.....	22
Factory Defaults & User Settings.....	23
Troubleshooting.....	23
Troubleshooting Tips.....	23
Quick User Interface Reference.....	24

Table of Figures

Figure 1. Enclosure Dimensions – Front View.....	9
Figure 2. Enclosure Dimensions – Side Cross Section View	9
Figure 3. Connector Board.....	10
Figure 4. Connections without Backlight	11
Figure 5. Connections with Loop-Powered Backlight.....	11
Figure 6. Connections with Externally-Powered Backlight.....	11
Figure 7. External Alarm Reset/Acknowledge Connections.....	11
Figure 8. Connection to Device with Internal Pull-Up	11
Figure 9. Output Connections	11

Specifications

Except where noted all specifications apply to operation at +25°C.

General

Display	Feet & Inches	0.60" (15.2 mm) high 0 to 699 ^{FT} 11 ¹⁵ / ₁₆ ^{IN} 7-segment, programmable 1/16 or 1/8 fraction display			
	Seven characters (Tag &/or Volume)	0.4" (10.2 mm) high 14-segment, 7-digits			
	Tank Level Indicator	20-segments			
Display Orientation	Display may be mounted at 90° increments up to 270° from default orientation.				
Display Assignment	Upper display: Feet & inches Lower display may be assigned to custom unit or tag, volume, volume and tag, percent height, percent height and tag, or off.				
Display Update Rate	Ambient > -25°C: 2 Updates/Second Ambient < -25°C: 1 Update/5 Seconds				
Backlight	White; Loop-powered or externally powered. Backlight can be enabled or disabled via alternative wiring of terminal block. Loop-powered backlight brightness will increase as the input signal current increases. Externally powered backlight has consistent brightness.				
Externally Powered Backlight	Voltage Range:	Maximum Power			
	9-36 VDC	9 VDC	12 VDC	24 VDC	36 VDC
		0.2 W	0.25 W	0.5 W	0.75 W
Overrange And Underrange	Level display flashes to 699 ^{FT} 11 ¹⁵ / ₁₆ ^{IN} Volume display flashes 999999 if overrange, -999999 if underrange.				
Programming Method	Four SafeTouch through-glass buttons when cover is installed. Four internal pushbuttons when cover is removed.				
Noise Filter	Programmable low (L ₀), medium (M ₀), high (H ₁), or off (OFF)				
Recalibration	Recalibration is recommended at least every 12 months.				
Max/Min Display	Max/Min readings reached by the process are stored until reset by the user or until power to the meter is turned off.				
Password	Programmable password restricts modification of programmed settings.				
Non-Volatile Memory	All programmed settings are stored in non-volatile memory for a minimum of ten years if power is lost.				
Normal Mode Rejection	64 dB at 50/60 Hz				
Environmental	Operating temperature range: -40 to 75°C Storage temperature range: -40 to 75°C Relative humidity: 0 to 90% non-condensing				
Connections	Screw terminals accept 12 to 22 AWG wire				
Enclosure	Explosion-proof die cast aluminum with glass window, corrosion resistant epoxy coating, color: blue. NEMA 4X, 7, & 9, IP68. Two 3/4" NPT threaded conduit openings. One 3/4" NPT metal conduit plug with 12 mm hex key fitting installed.				
Mounting	May be mounted directly to conduit. Two slotted flanges for wall mounting or NPS 1 1/2" to 2 1/2" or DN 40 to 65 mm pipe mounting. See <i>Dimensions</i> on page 9.				

Overall Dimensions	5.65" x 5.25" x 4.86" (W x H x D) (144 mm x 133 mm x 124 mm)
Weight	5.00 lbs (80 oz, 2.27 kg)
Warranty	3 years parts and labor. See Warranty Information and Terms & Conditions on www.prediq.com for complete details.

Input

Input	4-20 mA	
Accuracy	±0.03% of calibrated span ±1 count	
Maximum Voltage Drop & Equivalent Resistance	Without Backlight or with Externally Powered Backlight	With Loop-Powered Backlight
	3.0 VDC @ 20 mA 150 Ω @ 20 mA	6.0 VDC @ 20 mA 300 Ω @ 20 mA
Temperature Drift	50 PPM/°C from -40 to 75°C ambient	
Multi-Point Linearization	2 to 32 points, level and volume independently programmed.	
Minimum Span	Input 1 & Input 2: 0.10 mA	
Calibration Range	An <i>Error</i> message will appear if input 1 and input 2 signals are too close together.	
	Input Range	Minimum Span Input 1 & Input 2
	4-20 mA	0.10 mA
Input Overload	Over current protection to 2 A max.	
HART Transparency	The meter does not interfere with existing HART communications; it displays the 4-20 mA primary variable and it allows the HART communications to pass through without interruption. The meter is not affected if a HART communicator is connected to the loop. The meter does not display secondary HART variables.	

Open Collector Output

Rating	Isolated open collector, sinking NPN 30 VDC @ 150 mA max.
Alarm Output	Assign to level or volume for high or low alarm trip point.
Deadband	0-100% FS, user selectable
Acknowledge	Front panel ENTER button and external RESET terminals resets output and screen indication.

Product Ratings and Approvals

FM	Explosion-proof for use in: Class I, Division 1, Groups B, C and D Dust-ignition proof for use in: Class II/III, Division 1, Groups E, F and G; T6 Flame-proof for use in: Class I, Zone 1, AEx d Group IIC; T6 Protection by Enclosure: Zone 21, AEx tb IIIC; T85°C Ta = -40 to 75°C. Enclosure: Type 4X, IP66. Certificate number: 3040391
CSA	Explosion-proof for use in: Class I, Division 1, Groups B, C and D Dust-ignition proof for use in: Class II/III, Division 1, Groups E, F and G; T6 Flame-proof for use in: Zone 1, Ex d IIC T6 Ta = -40 to 75°C. Enclosure: Type 4X & IP66/IP68. Certificate number: 2325749
ATEX	 II 2 G D. Flame-proof for use in: Zone 1, Ex d IIC T6 Gb Protection by Enclosure for use in: Dust Atmospheres (Zone 21) Ex tb IIIC T85°C Db IP68. Ta = -40°C to +75°C Certificate number: Sira 10ATEX1116X
IECEX	Flame-proof for use in: Zone 1, Ex d IIC T6 Gb Protection by Enclosure for use in: Dust Atmospheres (Zone 21) Ex tb IIIC T85°C Db IP68. Ta = -40°C to +75°C Certificate number: IECEX SIR 10.0056X

Electromagnetic Compatibility

Emissions	EN 61326 Safety requirements for measurement, control, and laboratory use – Industrial Group 1 Class A ISM emissions requirements
Radiated Emissions	Class A
Immunity	EN 61326 Safety requirements for measurement, control, and laboratory use
ESD	±4 kV contact, ±8 kV air
RFI – Amplitude Modulated	80-1000 MHz @ 10 V/m, 1.4-2.0 GHz @ 3 V/m, 2.0-2.7 GHz @ 1 V/m, 80% AM (1 kHz)
EFT	±2 kV DC mains, ±1 kV other
Telco Surge	±1 kV
CRFI	3 V, 0.15-80 MHz, 1 kHz 80% AM

Special Conditions for Safe Use:

Use suitably certified and dimensioned cable entry device and/or plug. The equipment shall be installed such that the supply cable is protected from mechanical damage. The cable shall not be subjected to tension or torque. If the cable is to be terminated within an explosive atmosphere, then appropriate protection of the free end of the cable shall be provided.

Year of Construction:

This information is contained within the serial number with the first four digits representing the year and month in the YYMM format.

For European Community: The PD6801 must be installed in accordance with the ATEX directive 94/9/EC, and the product certificate Sira 10ATEX1116X.

EU Declaration of Conformity

EU Declaration of Conformity is available in the Documentation CD provided with the product under the **EU DoC** menu.

Safety Information

WARNINGS

- Read complete instructions prior to installation and operation of the meter.
- Installation and service should be performed only by trained service personnel. Service requiring replacement of internal components must be performed at the factory.
- Disconnect from supply before opening enclosure. Keep cover tight while circuits are alive. Conduit seals must be installed within 18" (450mm) of the enclosure.
- Verify that the operating atmosphere of the meter is consistent with the appropriate hazardous locations certifications.
- If the meter is installed in a high voltage environment and a fault or installation error occurs, high voltage may be present on any lead.

Installation

For Installation in USA: The PD6801 must be installed in accordance with the National Electrical Code (NEC) NFPA 70.

For Installation in Canada: The PD6801 must be installed in accordance with the Canadian Electrical Code CSA 22.1. All input circuits must be derived from a CSA approved Class 2 source.

For European Community: The PD6801 must be installed in accordance with the ATEX directive 94/9/EC and the product certificate Sira 10ATEX1116X.

⚠ WARNING

- Disconnect from supply before opening enclosure. Keep cover tight while circuits are alive. Conduit seals must be installed within 18" (450mm) of the enclosure.

Wiring connectors are accessed by opening the enclosure. To access electrical connectors, remove the 2 captive screws, then disconnect the ribbon cable from the display module and set the display module aside.

Unpacking

Remove the meter from box. Inspect the packaging and contents for damage. Report damages, if any, to the carrier.

If any part is missing or the meter malfunctions, please contact your supplier or the factory for assistance.

Pre-Installed Conduit Plug

The PD6801 is supplied with one pre-installed conduit plug for installations that do not require the use of both conduit entries. The conduit/stopping plug includes an internal hexagonal socket recess for removal. The conduit plug and its factory installation are included in all hazardous area approvals of this product.

⚠ WARNING

- In hazardous areas, conduit and conduit/stopping plugs require the application of non-setting (solvent free) thread sealant. It is critical that all relevant hazardous area guidelines be followed for the installation or replacement of conduit or plugs.

Mounting

The PD6801 has two slotted mounting flanges that may be used for pipe mounting or wall mounting. Alternatively, the unit may be supported by the conduit using the conduit holes provided.

Refer to

Figure 1 and Figure 2.

⚠ WARNING

- Do not attempt to loosen or remove flange bolts while the meter is in service.

Dimensions

All units: inches [mm]

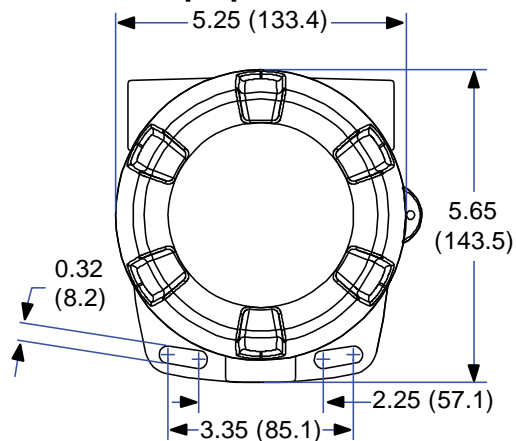

Figure 1. Enclosure Dimensions – Front View

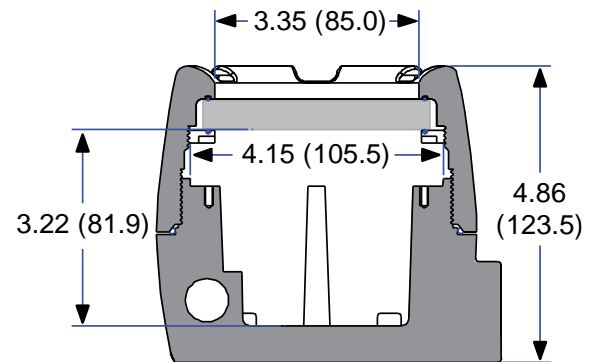

Figure 2. Enclosure Dimensions – Side Cross Section View



Download free 3-D CAD files of these instruments to simplify your drawings!

predig.com/documentation-cad

Cover Jam Screw

The cover jam screw should be properly installed once the meter has been wired and tested in a safe environment. The cover jam screw is intended to prevent the removal of the meter cover in a flameproof environment without the use of tools. Using a M2 hex wrench, turn the screw clockwise until the screw contacts the meter. Turn the screw an additional 1/4 to 1/2 turn to secure the cover. Caution: Excess torque may damage the threads and/or wrench.

Connections

To access the connectors, remove the enclosure cover and unscrew the two captive screws that fasten the display module. Disconnect the ribbon cable and remove the display module. Signal connections are made to a four-terminal connector in the base of the enclosure. Grounding connections are made to the two ground screws provided on the base – one internal and one external.

SIGNAL +	4-20 mA signal input positive terminal connection
SIGNAL -	4-20 mA signal return/negative terminal connection when not using loop powered backlight.
BACKLIGHT +	+9-30 VDC when powering backlight from external supply.
BACKLIGHT -	4-20 mA signal return/negative terminal when using the installed loop powered backlight or ground/negative when powering backlight from external supply.
OUTPUT+	NPN open collector output positive.
OUTPUT-	NPN open collector output negative.
RESET +	Contact closure alarm acknowledge pull up to 3 VDC.
RESET-	Contact closure alarm acknowledge ground/negative.

Refer to *Figure 3* for terminal positions.

⚠ WARNINGS

- Observe all safety regulations. Electrical wiring should be performed in accordance with all agency requirements and applicable national, state, and local codes to prevent damage to the meter and ensure personnel safety.
- Static electricity can damage sensitive components.
- Observe safe handling precautions for static-sensitive components.
- Use proper grounding procedures/codes.
- If the meter is installed in a high voltage environment and a fault or installation error occurs, high voltage may be present on any lead or terminal.

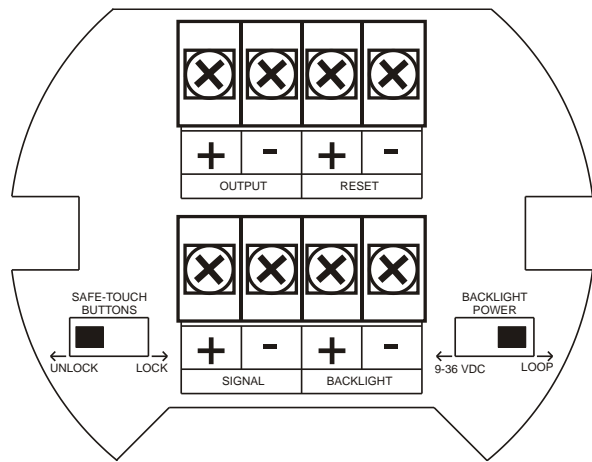

Figure 3. Connector Board

Wiring Diagrams

Signal connections are made to a four-terminal connector mounted in the base of the enclosure per *Figure 3. Connector Board*. The enclosure also provides one internal and one external earth grounding screw.

For installations that don't use the backlight, the maximum voltage drop is 3 V and connections are made per *Figure 4*.

For installations that use the backlight powered from the meter, the maximum voltage drop is 6 V and connections are made per *Figure 5*.

For installations that use the backlight powered from an external source, the maximum voltage drop is 3 V and connections are made per *Figure 6*.

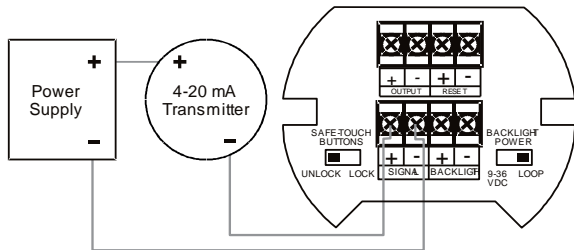

Figure 4. Connections without Backlight

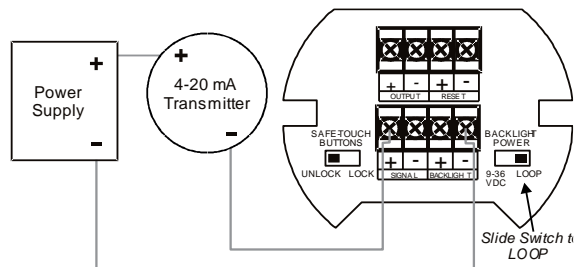

Figure 5. Connections with Loop-Powered Backlight

Loop-powered backlight brightness will increase as the input signal current increases. If constant backlight brightness is desired, the backlight should be powered by an external source.

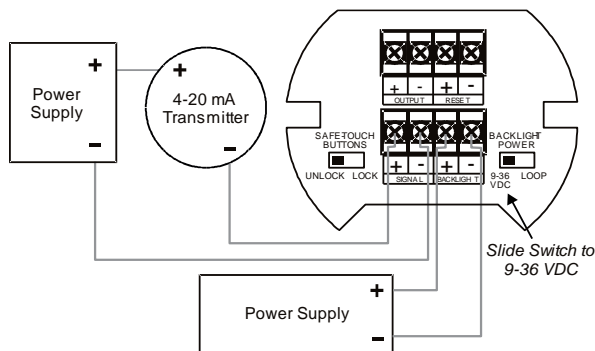

Figure 6. Connections with Externally-Powered Backlight

It is possible to use the same transmitter (signal loop) power supply for the externally powered backlight. The backlight circuit will draw 25 mA in addition to the loop circuit.

External Acknowledge Connection

External acknowledge connections are made to two terminals labeled RESET. Connect to a contact closure source such as a relay or a pushbutton as shown in *Figure 7*.

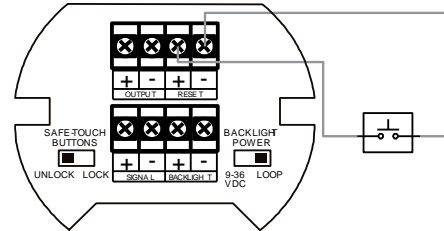

Figure 7. External Alarm Reset/Acknowledge Connections

Open Collector Output Connections

Output connections are made to two terminals labeled OUTPUT. Connect to an input device such as alarm indicator as shown in *Figure 8* or drive a relay as shown in *Figure 9*.

WARNING

- To avoid damaging the PD6801's amplifying components, use care not to wire incorrectly or exceed output ratings. A diode, such as 1N4000 series, will provide protection from relay transients.

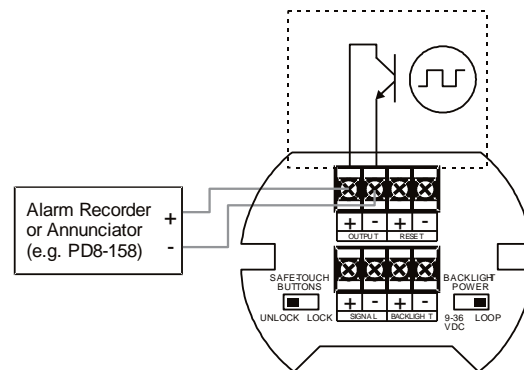

Figure 8. Connection to Device with Internal Pull-Up

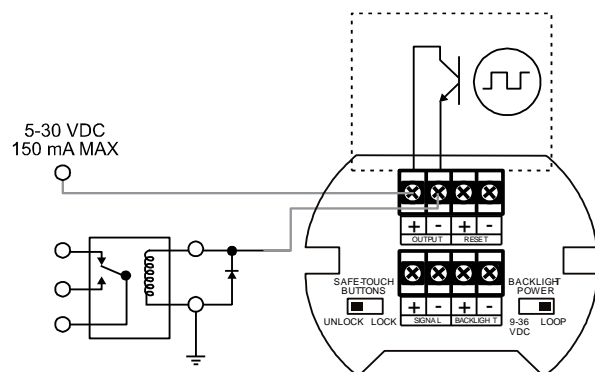

Figure 9. Output Connections

Setup and Programming

There is **no need to recalibrate** the meter for milliamps when first received from the factory.

The meter is **factory calibrated** for milliamps prior to shipment. The calibration equipment is traceable to NIST standards.

Overview

Setup and programming is done through the infrared through-glass SafeTouch buttons or using the mechanical buttons when uncovered. There are two slide switches located on the connector board. One is used to select backlight power and the other is to lock or unlock the SafeTouch Buttons.

After all connections have been completed and verified, connect the ribbon cable to the display module, fasten the display module to the base, install enclosure cover, and then apply power.

SafeTouch Buttons

The PD6801 is equipped with four sensors that operate as through-glass buttons so that it can be programmed and operated without removing the cover (and exposing the electronics) in a hazardous area. These buttons can be disabled for security by selecting the LOCK setting on the SAFE-TOUCH BUTTONS switch located on the connector board in the base of the enclosure.

SafeTouch Button Operation

To actuate a button, press and remove one finger to the glass directly over the marked button area. Remove finger to at least 4 inches away from the glass in between button activations. SafeTouch and mechanical buttons may be held to cycle through menus or digits in place of repeatedly pushing a button. The sensors are disabled when a mechanical button is pressed and will automatically be re-enabled after 60 seconds of inactivity.

SafeTouch Button Tips and Troubleshooting

The SafeTouch buttons are designed to filter normal levels of ambient interference and to protect against false triggering, however, it is recommended that the SafeTouch buttons be disabled (slide switch to LOCK) if there is an infrared interference source in line-of-sight to the display.

SafeTouch Button Tips:

- To the extent possible, install the display facing away from sunlight, windows, reflective objects and any sources of infrared interference.
- Keep the glass window clean.
- Tighten the cover securely.
- Use a password to prevent tampering.
- If the cover has not been installed and secured tightly, it may take a moment for the SafeTouch buttons to properly self-calibrate when the cover is tightened.

IMPORTANT

- SafeTouch buttons will not work if two or more buttons are detected as being pressed simultaneously. As a result, be careful to avoid triggering multiple buttons or reaching across one button location to press another.

Buttons and Display

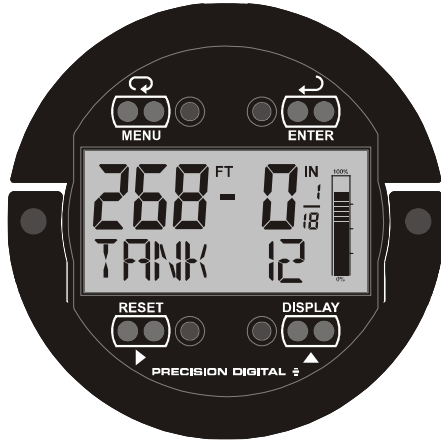

Button Symbol	Description
	Menu
	Right arrow/Reset
	Up arrow/Display
	Enter/Alarm Acknowledge

Symbol	Status
FT	Feet
IN	Inches and Fractional Inches
	20-Segment Tank Level Indicator Bargraph
	Password Enabled

Menu Button

- Press the **Menu** button to enter Programming Mode.
- Press the **Menu** button during Programming Mode to return to the previous menu selections.
- Hold the **Menu** button for 1.5 seconds at any time to exit Programming Mode and return to *Run Mode*.
- Press and hold the **Menu** button for 5 seconds to access the *Advanced Features* of the meter.

Right / Reset Button

- Press the Right arrow button to reset the maximum or minimum value while it is being displayed (see **Up / Display Button** below).
- Press the **Right** arrow button to move to the next digit or decimal position during programming.
- Press **Right** to go backward through most selection menus.

Up / Display Button

- Press Display when in Run Mode to cycle through displaying the maximum value, minimum value, and the loop input value in mA. The display will time out in 12 seconds. Press Display again to resume normal lower display operation (lower display will read *RESUME*).
- Press the **Up** arrow button to scroll forward through the menus, decimal point, or to increment the value of a digit.

Enter Button

- Press the **Enter** button to access a menu or to accept a setting.
- Press **Enter** to acknowledge alarm (if enabled).

Main Menu Display Functions & Messages

The meter displays various functions and messages during setup, programming, and operation. The following table shows the main menu functions and messages in the order they appear in the menu.

Display	Parameter	Action/Setting
SETUP	Setup	Enter Setup menu
SCALE	Scale	Enter the Scale menu for feet and inches
INPUT 1	Input 1	Set input 1 value in mA
DISPLY 1	Display 1	Set display 1 feet and inches
INPUT 2	Input 2	Set input 2 value in mA
DISPLY 2	Display 2	Set display 2 feet and inches
SAVE ?	Save	Save entered scale parameters
SPN ERR	Span Error	Scale point 1 and 2 span error
FRACTN	Fraction	Enter the Program menu
1/16th	1/16 th	Set display for 1/16 th inch fractions
OFF	Off	Turn off inch fraction display
1/8th	1/8 th	Set display for 1/8 th inch fractions
PERCENT	Percent	Scale the tank indicator full and empty values
0 PCT	0 Percent	Set the tank empty value
100 PCT	100 Percent	Set the tank full value
DISPLAY	Display	Enter Lower Display menu
TAG	Tag	Display a custom unit or tag
VOLUME	Volume	Display volume
VOLTAG	Volume + Tag	Display volume and custom tag
PCT HT	Percent Height	Display percent height
PCTTAG	Percent Height + Tag	Display percent height and custom tag

Main Menu

The main menu consists of the most commonly used functions: *Setup*, *Advanced*, and *Password*.

Press **MENU** button to enter *Programming Mode* then press the **Up Arrow** button to scroll through the main menu.

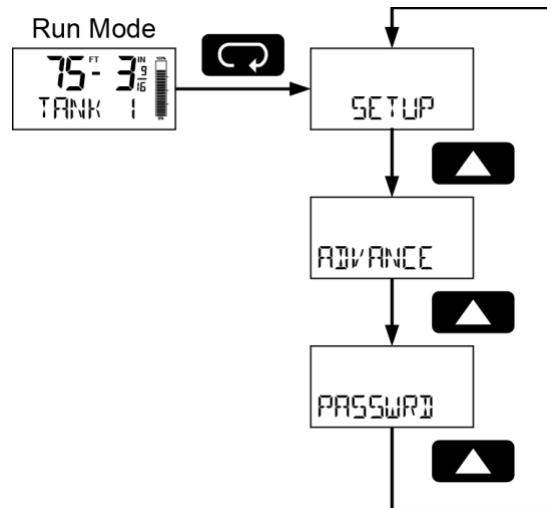

Hold **MENU**, at any time, to exit and return to *Run Mode*. Changes made to settings prior to pressing **ENTER** are not saved.

Press the **MENU** button during *Programming Mode* to return to the previous menu selections.

Changes to the settings are saved to memory only after pressing **ENTER**.

The display moves to the next menu every time a setting is accepted by pressing **ENTER**.

Setting Up the Meter (SETUP)

The *Setup* menu is used to select:

1. Feet and inches display scale
2. Inch fraction display mode
3. Tank indicator full value
4. Lower display selection

Press the **ENTER** button to access any menu or press **UP** arrow button to scroll through choices.

Hold **MENU**, at any time, to exit and return to Run Mode. Changes made to settings prior to pressing **ENTER** are not saved.

Press the **MENU** button during Programming Mode to return to the previous menu selections.

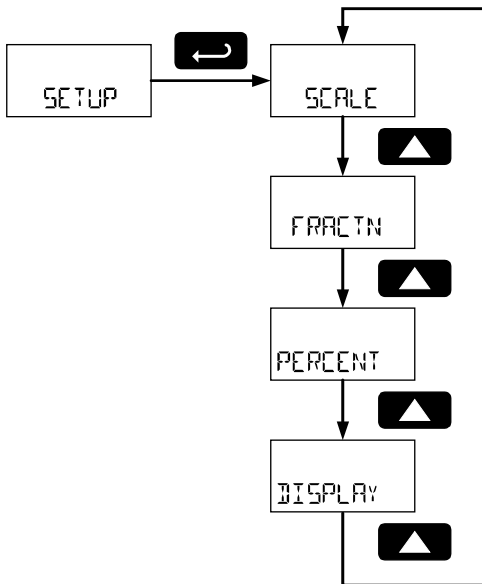

Setting Numeric Values

The numeric values are set using the **RIGHT** and **UP** arrow buttons. Press **RIGHT** arrow to select next digit and **UP** arrow to increment digit.

The digit being changed blinks.

Press the **ENTER** button, at any time, to accept a setting.

Hold **MENU**, at any time, to exit and return to Run Mode. Changes made to settings prior to pressing **ENTER** are not saved.

Press the **MENU** button during Programming Mode to return to return to the previous menu selections.

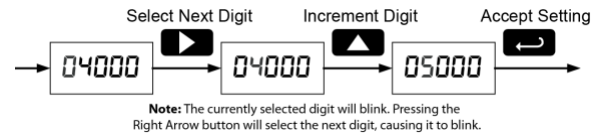

Scaling the Meter (SCALE)

The 4-20 mA input can be scaled to display the process in engineering units. To scale the meter, enter the value in milliamps (mA) for input 1, and then the corresponding engineering units display value. Do the same for input 2.

After entering the display 2 value, confirm the new scale by pressing **ENTER** at the Save menu.

A signal source is not needed to scale the meter; simply program the inputs and corresponding display values.

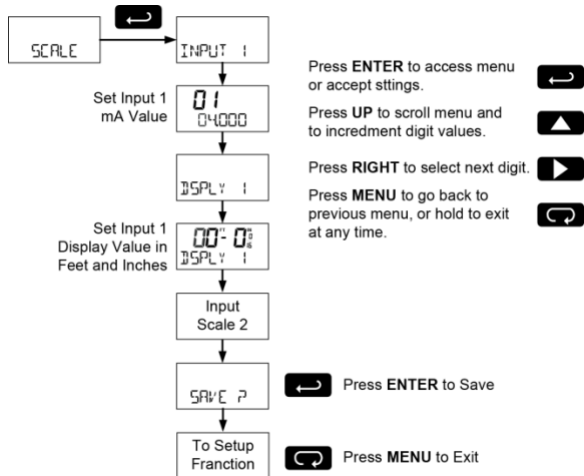

For instructions on using multipoint scaling, see *Level Input Multipoint Linearization (MULTIPOINT)*, page 20.

For instructions on how to program numeric values see *Setting Numeric Values* on page 15.

Minimum Input Span

The minimum input span is the minimum difference between input 1 and input 2 signals required to complete the calibration or scaling of the meter. The minimum span is 0.10 mA.

Scale Error Message (SPN ERR)

If the minimum span is not maintained, the meter will show a span error (SPN ERR) and revert to input 2, allowing the appropriate input signals to be applied.

Selecting Inch Fraction Display Mode (FRACTN)

The display may be programmed to display fractions of an in 1/8th or 1/16th increments, or to show no fraction.

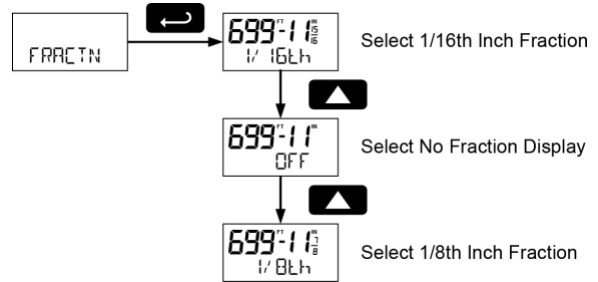

Scaling the Tank Level Indicator (PERCENT)

The display includes a 20-segment tank height indicator. This menu sets full and empty values, in feet and inches, for the tank height indicator. This value may differ from the 20 mA full-scale and 4 mA empty-scale values programmed in the *Scale* menu. This is ideal for level transmitters that output less than 20 mA at the maximum height of the tank or pit or more than 4 mA at the minimum height.

As an example, when using a level transmitter that outputs 20 mA at 250 feet, the tank height indicator may be set for 100 feet, 0 inches. At 100 feet 0 inches on the display, the tank height indicator will show as full, even though the input is not 20 mA.

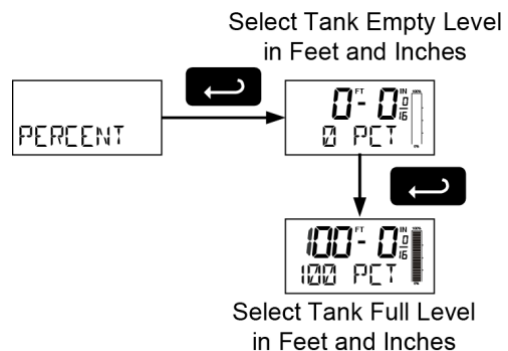

Advanced Features Menu (ADVANCE)

To simplify the setup process, functions not needed for most applications are located in the *Advanced Features Menu*. Access the *Advanced Features Menu* by pressing **ENTER** at the ADVANCE menu in the *Main Menu* defined on page 14.

The *Advanced Features Menu* is used to select:

1. Open collector output configuration (OUTPUT)
2. Input filter (FILTER)
3. Volume display scale (VOLSCALE)
4. Live signal level display calibration (LVL CAL)
5. Internal Calibration (ICAL)
6. Multipoint linearization for level (MULTIPT)
7. Meter system information display (INFO)

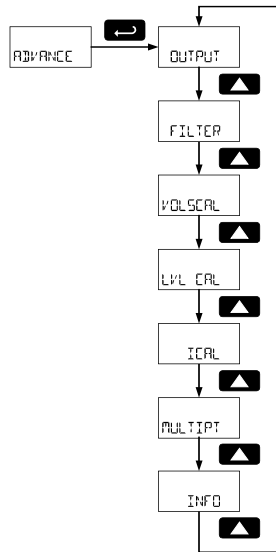

Advanced Features Menu & Display Messages

The following table shows the *Advanced* features menu functions and messages in the order they appear in the menu.

Display	Parameter	Action/Setting
OUTPUT	Output	Enter output menu
OFF	Off	Disable output
ALARM	Alarm Output	Enter alarm output menu
LEVEL	Level Alarm	Assign alarm output to level
SET	Set Point	Set alarm set point
RESET	Reset Point	Set alarm reset point
VOLUME	Volume Alarm	Assign alarm output to volume
FILTER	Filter	Set noise filter
LO	Filter Low	Set noise filter to low setting
MED	Filter Medium	Set noise filter to medium setting
HI	Filter High	Set noise filter to high setting
OFF	Filter Off	Disable noise filter
VOLSCALE	Volume Scale	Scale the volume display
NO PTS	Number of	Set the number of

Display	Parameter	Action/Setting
	Points	points for volume scaling
INPUT 1	Input 1	Set volume input 1 on the level display
DISPLY 1	Display 1	Set volume display 1
INPUT 2	Input 2	Set volume input 2 on the level display
DISPLY 2	Display 2	Set volume display 2
SAVE P	Save	Save entered volume scale parameters
LVL CAL	Level Calibration	Calibrate the level display
INPUT 1	Input 1	Calibrate input 1 value
DISPLY 1	Display 1	Set display 1 feet and inches
INPUT 2	Input 2	Calibrate input 2 value
DISPLY 2	Display 2	Set display 2 feet and inches
SAVE P	Save	Save entered calibration parameters
ICAL	Internal Calibration	Enter internal reference calibration
4mA	4 mA	Calibrate input at 4 mA
20mA	20 mA	Calibrate input at 20 mA
ERRSPAN	Error Span	Error with calibration point 1 and 2 span
MULTIPT	Multipoint	Set level display multipoint linearization
DISABLE	Disable	Disable multipoint linearization
ENABLE	Enable	Enable multipoint linearization
INFO	Meter Information	Show software number and version, or reset to factory defaults
SOFT	Software	Software number
VERSION	Software Version	Software version

For instructions on how to program numeric values, see *Setting Numeric Values* on page 15.

Level Input Live Signal Calibration (LVL CAL)

The meter can be calibrated using a current source instead of scaling. This process will override previously programmed scaling of the level display. The use of a calibrated signal source is strongly recommended.

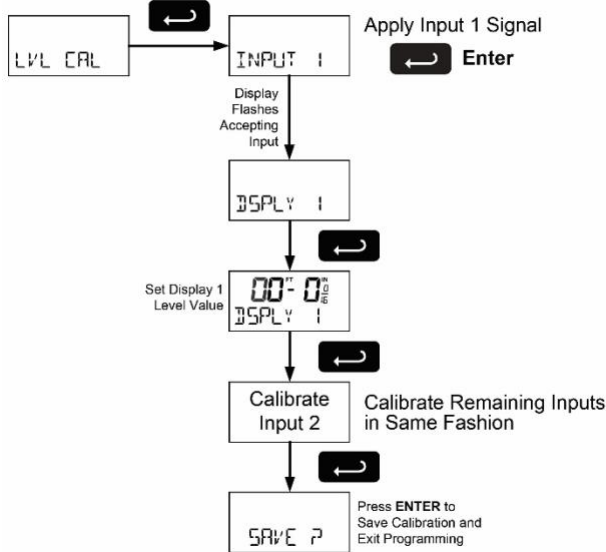

Internal Calibration (ICAL)

There is **no need to recalibrate** the meter when first received from the factory. The meter is **factory calibrated** prior to shipment. The calibration equipment is traceable to NIST standards

The internal calibration is the meter's master calibration that makes scaling the meter without a signal source possible. Use of a calibrated signal source is necessary to perform an internal calibration of the meter. Check calibration of the meter at least every 12 months. Incorrect calibration will affect the ability of the meter to properly read, scale, and display the input.

Notes:
 The signal source must have a full-scale accuracy of 0.002% or better between 4 and 20 mA in order to maintain the specified accuracy of the meter.
 Allow the meter to warm up for at least 15 minutes before performing the calibration procedure.

Press and hold the **MENU** button for 5 seconds to enter the *Advanced Features* menu. Press the **UP** arrow button to scroll to the *Internal Calibration* menu (ICAL) and press **ENTER**.

The meter displays 4 mA. Apply a 4.000 mA signal and press **ENTER**. The display flashes for a moment while the meter is accepting the signal.

After the signal is accepted, the meter displays 20 mA. Apply a 20.000 mA signal and press **ENTER**. The display flashes for a moment while the meter is accepting the signal.

Calibration Error Message (SPN ERR)

An error message indicates that the calibration process was not successful. After the error message is displayed, the meter will revert to the 4 mA calibration menu. The error message might be caused by inadvertently leaving the signal at the previous level or not maintaining the minimum span. Press the **MENU** button to cancel the current calibration process if necessary.

Level Input Multipoint Linearization (MULTIPT)

This menu enables multipoint linearization for scaling and calibrating of the level display.

Setting **MULTIPT** to **ENABLE** allows the level display to be scaled or calibrated using up to 32 points. See *Scaling the Meter (SCALE)* on page 16 and *Level Input Live Signal Calibration (LVL CAL)* on page 20, to include a *Number of Points (NO PTS)* parameter before entering *Input 1*.

32-point linearization can be used to linearize the display for non-linear signals.

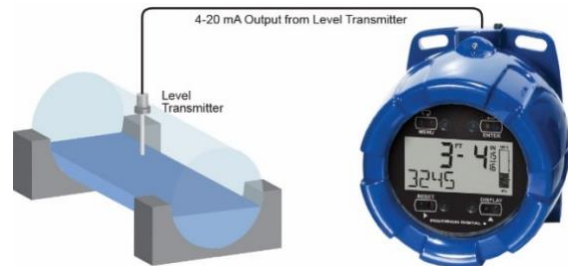

PD6801 Displaying Height in Feet and Inches and Volume (Using Multi-Point Linearization Feature) in Gallons in a Round Horizontal Tank.

Information (INFO)

The *Information* menu shows the software identification number and version number.

To determine the software version of a meter:

Go to the *Information* menu (INFO) and press **ENTER** button.

Continue pressing **ENTER** to scroll through the software release number and software version.

Following the information display, the meter will exit the *Advanced Features* menu and return to run mode.

Setting Up the Password (PASSWORD)

The *Password* menu is used to program a five-digit password to prevent unauthorized changes to the programmed parameter settings. A password protected meter will display **LOCKED** when the **MENU** button is pressed.

Locking the Meter

Enter the *Password* menu and program a five-digit password.

For instructions on how to program numeric values see *Setting Numeric Values*, page 15.

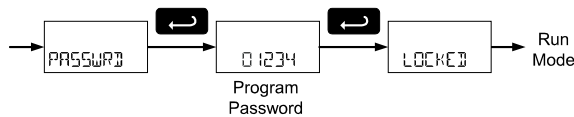

Record the password for future reference. If appropriate, it may be recorded in the space provided.

Model:	
Serial Number:	
Password:	_ _ _ _ _

Making Changes to a Password Protected Meter

If the meter is password protected, the meter will display the message **LOCKED** when the Menu button is pressed. Press the Enter button while the message is being displayed and enter the correct password to gain access to the menu. After exiting the programming mode, the meter returns to its password protected condition.

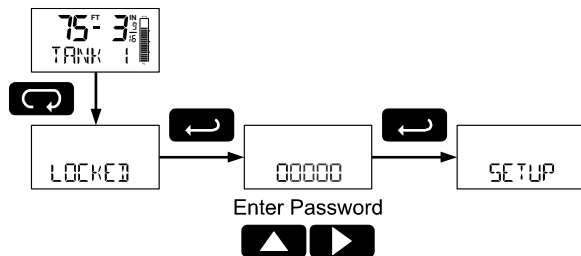

Disabling Password Protection

To disable the password protection, access the *Password* menu and enter the correct password, as shown below.

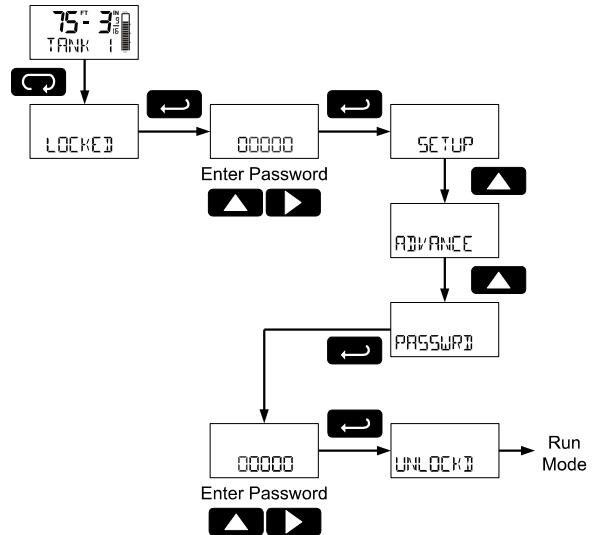

If the correct five-digit password is entered, the meter displays the message **UNLOCKED** (*unlocked*) and the protection is disabled until a new password is programmed.





If the password entered is incorrect, the meter displays the message **LOCKED** and returns to Run Mode. To try again, repeat the above procedure.

Did you forget the password?

The password may be disabled by entering a master password. If you are authorized to make changes, enter the master password 50865 to unlock the meter.

Operation

Front Panel Buttons Operation

Button Symbol	Description
	Press to Enter or Exit Programming Mode
	Used to Reset Maximum and Minimum Values
	Press to Cycle Displaying Maximum Value, Minimum Value, and Input Current in mA Press to Resume Run Mode in Lower Display
	Press to Acknowledge Alarm (if Enabled)

Display Maximum, Minimum, and Input Current

The maximum and minimum values and the measured input loop current may be displayed temporarily on the lower display. To display these values, press the **DISPLAY** button. The meter will display the word **MAXIMUM** on the lower display and the maximum value reached (since the last maximum reset) on the upper display. Press the **DISPLAY** button again and the meter will display the word **MINIMUM** on the lower display and the minimum value reached on the upper display. Pressing the **RESET** button while either of these values is displayed will reset that value to the current display value.

Press the **DISPLAY** button a third time and the meter will display **LOOP MA** on the lower display, followed by the measured input current in milliamps (mA). The current display will remain for 10 seconds and then the lower display will return to normal run mode as programmed in *Configuring the Lower Display (DISPLAY)* on page 17. Press the **DISPLAY** button a fourth time to return to the normal operation. The meter will display **RESUME** followed by the run mode lower display.

Reset Meter to Factory Defaults

When the parameters have been changed in a way that is difficult to determine what's happening, it might be better to start the setup process from the factory defaults.

Instructions to load factory defaults:

Enter the *Advanced* features menu.

Press and hold **RESET** button when **INFO** is shown. For information on navigating to the *Information* menu, refer to *Advanced Features Menu (ADVANCE)* on page 18.

Press **ENTER** when **DEFAULTS** prompt is flashing.

Note: If **ENTER** is not pressed within three seconds, the prompt will stop flashing return to run mode.

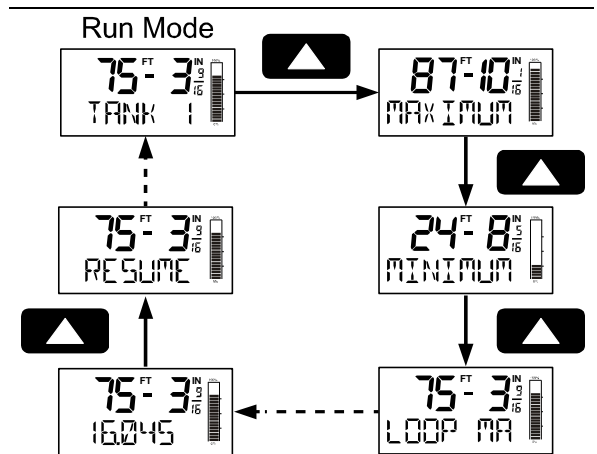
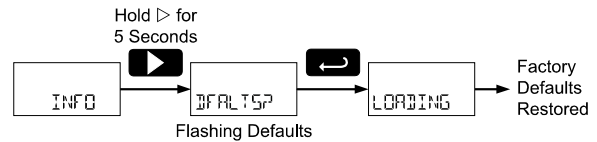

Factory Defaults & User Settings

The following table shows the factory setting for most of the programmable parameters on the meter. Next to the factory setting, the user may record the new setting for the particular application.

Model: _____

S/N: _____

Date: _____

Parameter	Display	Default Setting	User Setting
Basic Setup			
Input 1	INPUT 1	4.000 mA	
Display 1	DISP L Y 1	00 ^{ft} 00 ⁱⁿ ⁰ / ₁₆	
Input 2	INPUT 2	20.00 mA	
Display 2	DISP L Y 2	100 ^{ft} 00 ⁱⁿ ⁰ / ₁₆	
Fraction	FRACTN	1/16th	
Tank Indicator 0%	0 PCT	0 ^{ft} 00 ⁱⁿ ⁰ / ₁₆	
Tank Indicator 100%	100 PCT	100 ^{ft} 00 ⁱⁿ ⁰ / ₁₆	
Display	DISPLAY	Tag	
Bar Graph	GRAPH	On	
Tag	TAG	TANK 1	
Advanced Features			
Output	OUTPUT	Off	
Filter	FILTER	Low	
Volume Scale Number of Points	NO PTS	02	
Volume Scale Input 1	INPUT 1	00 ^{ft} 00 ⁱⁿ ⁰ / ₁₆	
Volume Display 1	DISP L Y 1	0	
Volume Scale Input 2	INPUT 2	100 ^{ft} 00 ⁱⁿ ⁰ / ₁₆	
Volume Display 2	DISP L Y 2	100,000	
Multipoint	MULTIPT	Disable	
Password			
Password	PASSWRD	00000 (unlocked)	

Troubleshooting

Due to the many features and functions of the meter, it's possible that the setup of the meter does not agree with what an operator expects to see. If the meter is not working as expected, refer to the *Diagnostics* menu and consult the recommendations described below.

Troubleshooting Tips

Symptom	Check/Action
No display or faint display	Check input signal connections. Perform hard reset by shorting S+ and S- terminals.
Level display unsteady	Increase filter setting in <i>Advanced</i> menu.
Meter displays error message during calibration (ERROR)	Check signal connections. Verify minimum input span requirements
Level display flashing 699 ^{ft} 11 ⁱⁿ .	Check input signal and scaling within range of 699 ^{ft} 11 ⁱⁿ .
Meter flashes 9999999 or -9999999	Check level display within volume scale range of 9999999 and -9999999.
Display response is too slow	Check filter setting to see if it can be lowered to LO or OFF .
If the display locks up or the meter does not respond at all	Perform hard reset by shorting S+ and S- terminals.
Backlight does not appear.	Backlight may not be noticeable under good lighting conditions. Check connections are as shown in <i>Figure 5. Connections with Loop-Powered Backlight</i> or <i>Figure 6. Connections with Externally-Powered Backlight</i> on page 11.
SafeTouch buttons do not respond	Mechanical buttons may have been pushed. The SafeTouch buttons will be re-enabled automatically 60 seconds after the last button push. If slide switch on connector board is in Lock position, switch to Unlock. Sunlight can interfere with the sensors. It is recommended to shield the window from sunlight while operating the buttons by standing so as to block direct sunlight.
Other symptoms not described above	Call Technical Support for assistance.

Quick User Interface Reference

Pushbutton	Function
MENU	Go to programming mode or leave programming. Hold for 5 seconds to enter <i>Advanced Features</i> menu directly.
RIGHT Arrow	Move to next digit. Go to previous menu or alphanumeric character selection. Reset max or min while displayed.
UP Arrow	Move to next selection or increment digit. Cycle through maximum, minimum, and mA display mode.
ENTER	Accept selection/value and move to next selection. Acknowledge alarms.

To enter the Advanced Features Menu, hold the **Menu** button for 5 seconds.

Max/Min Mode

While in Run Mode, pressing **Up** Arrow will initiate MAX/MIN Mode. **Up** Arrow toggles between MAX & MIN displays, and **Right** Arrow resets the MAX/MIN to the current value. Press **Menu** or wait 10 seconds to return to Run Mode. Pressing **Enter/Ack** will disable the 10 second timeout and continuously display Max or Min.

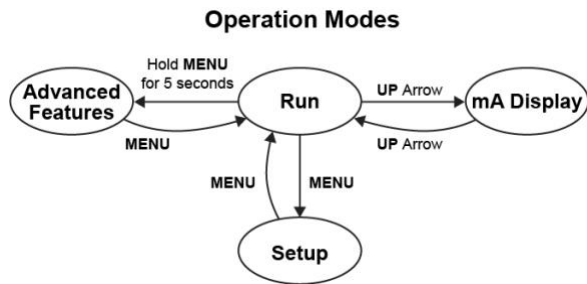

Main Menu

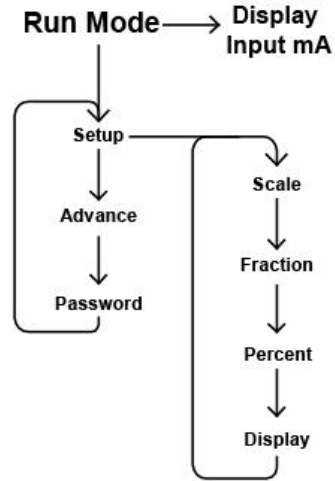

Advanced Menu

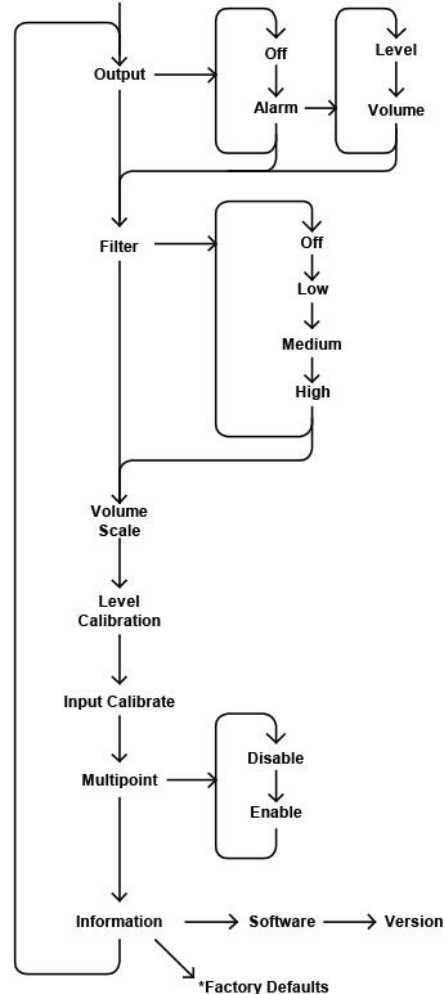

*Access by holding **Right/Reset** for 3 seconds

Contact Precision Digital

Technical Support

Call: (800) 610-5239 or (508) 655-7300

Fax: (508) 655-8990

Email: support@predig.com

Sales Support

Call: (800) 343-1001 or (508) 655-7300

Fax: (508) 655-8990

Email: sales@predig.com

Place Orders

Email: orders@predig.com

For the latest version of this manual please visit

www.predig.com

PRECISION DIGITAL CORPORATION

233 South Street • Hopkinton MA 01748 USA
Tel (800) 343-1001 • Fax (508) 655-8990

www.predig.com

