

PD6830 Explosion-Proof Pulse Input Rate/Totalizer

Instruction Manual



- Fully-Approved Explosion-Proof Pulse Input Rate/Totalizer
- Pulse, Open Collector, NPN, PNP, TTL, Switch Contact, Sine Wave (Coil), Square Wave, Isolated Inputs
- 0.7" (17.8 mm) 5 Digits Upper Display for Rate or Total
- 0.4" (10.2 mm) 7 Alphanumeric Characters Lower Display for Rate, Total, Grand Total, Units, and Tag
- Display Mountable at 0°, 90°, 180°, & 270°
- SafeTouch Through-Glass Button Programming
- 13-Digit Totalizer with Total Overflow Feature
- Gate Function for Rate Display of Slow Pulse Rates
- K-Factor, Scaling, or Live Input Calibration with 32-Point Linearization
- Automatic Rate, Total, and Grand Total Unit Conversions
- Backlight Standard on All Models
- Isolated 4-20 mA Output for Rate, Total, or Grand Total
- Two Isolated Open Collector Pulse Outputs, Up to 5 kHz
- Battery, DC, or Output Loop-Powered Models
- Operating Temperature Range: -40 to 75°C (-40 to 167°F)
- FM Approved as Explosion-Proof / Dust-Ignition Proof / Flame-Proof
- CSA Certified as Explosion-Proof / Dust-Ignition Proof / Flame-Proof
- ATEX and IECEx Certified as Flame-Proof and Protection by Enclosure
- Conformal Coated PCBs for Dust and Humidity Protection
- Password Protection
- On-Board Data Logging of up to 1024 points
- Free Meterview EX Programming Software
- Modbus Communications Isolated RS-485 Option
- Wide Viewing Angle
- Flanges for Wall or Pipe Mounting
- Explosion-Proof, IP68, NEMA 4X Die-Cast Aluminum Enclosure
- Three 3/4" NPT Threaded Conduit Openings (One Plug Installed)
- 2" U-Bolt Kits Available
- Stainless Steel Tag Available
- 3-Year Warranty

PRECISION DIGITAL CORPORATION

233 South Street • Hopkinton MA 01748 USA
Tel (800) 343-1001 • Fax (508) 655-8990

www.predig.com

**PRECISION
DIGITAL**

Disclaimer

The information contained in this document is subject to change without notice. Precision Digital Corporation makes no representations or warranties with respect to the contents hereof; and specifically disclaims any implied warranties of merchantability or fitness for a particular purpose.

CAUTION

- Read complete instructions prior to installation and operation of the meter.

WARNINGS

- Risk of electric shock or personal injury.
- This product is not recommended for life support applications or applications where malfunctioning could result in personal injury or property loss. Anyone using this product for such applications does so at his/her own risk. Precision Digital Corporation shall not be held liable for damages resulting from such improper use.
- Failure to follow installation guidelines could result in death or serious injury. Make sure only qualified personnel perform the installation.
- Never remove the meter cover in explosive environments when the circuit is live.
- Cover must be fully engaged to meet flameproof/explosion-proof requirements.

WARNING
Cancer and Reproductive Harm - www.P65Warnings.ca.gov

Limited Warranty

Precision Digital Corporation warrants this product against defects in material or workmanship for the specified period under "Specifications" from the date of shipment from the factory. Precision Digital's liability under this limited warranty shall not exceed the purchase value, repair, or replacement of the defective unit. See Warranty Information and Terms & Conditions on www.prediq.com for complete details.

© 2022 Precision Digital Corporation.
All rights reserved.

Introduction

The ProtEX-RTP PD6830 is a rugged, explosion-proof, pulse input rate/totalizer for demanding applications in hazardous areas. It can be powered from 9-30 VDC, battery, or from the 4-20 mA output loop; includes two isolated open collector pulse outputs and is available with an isolated RS-485 option for Modbus communications. The instrument will operate over a temperature range of -40 to 75°C (-40 to 167°F).

The top numeric display will read rate or total up to five digits and the alphanumeric bottom display will read up to 7 digits, 13 digits with the total overflow feature. The alphanumeric display can also be programmed to show any combination of numbers and letters up to seven characters long for rate, total, grand total, engineering units and/or identification tag. The backlight makes the display more visible in any lighting condition. The enclosure is provided with threaded conduit holes and integrated pipe or wall mounting flanges.

Free, PC-based, MeterView EX software that connects to the meter via the [PDA8068](#), [PDA7485-I](#), or the [PDA8485-I](#) is available for programming and setup of the instrument.



The instrument can also be programmed using the four SafeTouch through-glass buttons, without removing the cover, or with four internal push-buttons.

The PD6830 includes on-board data logging of up to 1024 points.

Ordering Information

Model	Description
PD6830-AP0-0	9-30 VDC Powered, Constant Backlight, 2 Pulse Outputs
PD6830-APA-0	9-30 VDC Powered, Constant Backlight, Isolated 4-20 mA Output, 2 Pulse Outputs
PD6830-BM0-0	Battery Powered ¹ , or DC-Powered with Battery Backup, Backlight ² , 2 Pulse Outputs
PD6830-BMA-0	Battery (or 9-30 VDC) Powered ¹ , or DC Powered with Battery Backup, Backlight ² , Isolated 4-20 mA Output, 2 Pulse Outputs
PD6830-BTA-0	Battery Powered ¹ , or DC Powered with Battery Backup, Loop Output Powered Backlight, Isolated 4-20 mA Output, 2 Pulse Outputs
PD6830-CTB-0	4-20 mA Output-Powered, Loop-Powered Backlight, Non-Isolated 4-20 mA Output, 2 Pulse Outputs
PD6830-DTB-0	4-20 mA Output-Powered with Battery Backup, Loop Output Powered Backlight ² , Non-Isolated 4-20 mA Output, 2 Pulse Outputs
-I Option	Isolated 2-wire RS-485 with Modbus protocol ³ . Replace ending -0 in part number above with -I (Example: PD6830-APA-I). Not available on -CTB or -DTB models.

Notes:

1. When DC-powered, battery will provide backup power when DC power is lost.
2. Backlight is constant when DC powered and momentary when battery powered.
3. Communication disabled when actively powered by battery.

Accessories

Model	Description
PDAPLUG75	3/4" Metal Conduit/Stopping Plug
PDABAT36C	3.6 V C Cell Lithium Battery
PDA0001	3/4" M-NPT to F-M20 Reducer
PDA0002	3/4" M-NPT to 1/2" F-NPT Reducer
PDA1024-01	24 VDC Power Supply for DIN Rail
PDA8068	USB Serial Adapter for Programming
PDA7485-I	RS-232 to RS-485 Isolated Converter
PDA8485-I	USB to RS-485 Isolated Converter
PDA6846	Steel 2" U-Bolt Kit. All Material: Zinc Plated Steel; (1) U-Bolt for 2" Pipe with (2 each) Washers, Lock Washers, and Nuts.
PDA6846-SS	Stainless Steel 2" U-Bolt Kit. All Material: Stainless Steel; (1) U-Bolt for 2" Pipe with (2 each) Washers, Lock Washers, and Nuts.
PDA-SSTAG	Custom Stainless Steel Tag (see website for convenient ordering form)

PDA1024-01 24 VDC Power Supply



The PDA1024-01 is a DIN rail mounted 1.5 A, 24 VDC power supply that can be used to power the PD6830.

PDA8068 USB Serial Adapter



The PDA8068 USB serial adapter is used to connect the PD6830 directly to a computer via USB. It is intended to be used for programming only. No live monitoring is possible with this module.

PDA6846 2" U-Bolt Kits



The PDA6846 U-Bolt Kits provide a convenient way to mount the PD6830 to 1.5" or 2" pipes. They are available in steel and stainless steel.

PDA-SSTAG Stainless Steel Tag



The PDA-SSTAG is a laser etched stainless steel tag that can be customized with three lines of text. Each tag comes with a stainless steel wire and lead seal for easy mounting wherever you need.

Helpful Videos

The following videos might be of interest.

PD6830 ProtEX Pulse Input Flow Rate/Totalizer

Learn all about the PD6830.



<https://www.predig.com/videos/9Wwar2-G3j8>

ProtEX Explosion-Proof Meter Introduction

Learn about all the meters in the ProteX Series.



https://www.predig.com/videos/rJsvL_8PEyc

ProtEX Approvals Overview

The ProtEX Series carries extensive international approvals for hazardous areas.



<https://www.predig.com/videos/CTsNXQeRqTA>

ProtEX Enclosure Unique Features

Learn about the unique features of the ProtEX Series enclosures.



<https://www.predig.com/videos/SwWKJ3L8ibo>

Introduction to ProtEX SafeTouch Programming

Through-glass buttons make programming easy without removing the enclosure's cover.



https://www.predig.com/videos/SafeTouch_Buttons

Vantageview Series Introduction

This series designed for use in safe areas delivers the same functionality of the ProtEX Series in a rugged plastic enclosure.



https://www.predig.com/videos/OC_trhGqTtWU

Table of Contents

Introduction	2
Ordering Information	3
Specifications.....	7
General	7
Rate Input	8
Rate/Totalizer	8
4-20 mA Transmitter Output	9
Open Collector Output	9
Serial Communications.....	9
MeterView EX Programming Software	10
Product Ratings and Approvals.....	11
Electromagnetic Compatibility.....	11
EU Declaration of Conformity.....	12
Safety Information	12
Installation	12
Unpacking	12
Pre-Installed Conduit Plug.....	12
Battery Activation Pull Tab.....	13
Mounting	13
Dimensions	13
Cover Jam Screw.....	14
Connections.....	14
Wiring Diagrams	15
Input Signal Connections	15
DC Power Connection.....	15
External Total Reset Connection.....	16
4-20 mA Transmitter Output Connections.....	16
RS-485 Serial Connections	16
Open Collector Output Connections.....	16
Battery Replacement.....	17
Setup and Programming	17
Overview.....	17
MeterView EX Programming Software	17
SafeTouch Buttons.....	18
SafeTouch Button Tips and Troubleshooting.....	18
Buttons and Display	19
Setting Numeric Values	20
Setting Alphanumeric Labels (LAbEL).....	20
Main Menu	20
Setup Menu Display Functions & Messages	21
Setting Up the Meter (SETUP)	22
Selecting Input Type (InPuT)	23
Entering the K-Factor (FAcTOr).....	24
Display Units (UnItS).....	24
Setting the Decimal Point (dEcPt)	28
Configuring the Display (dSPly).....	29
Advanced Features Menu	30
Advanced Features Menu & Display Messages.....	30
Open Collector Outputs (OuTpuT)	32
Scaling the 4-20 mA Analog Output (RouT).....	35
Gate Function (GATE)	35
Contact Debounce Filter (FiLTER)	35
Low-Flow Cutoff (CuTOff)	35
Scaling & Calibration (SEALCAL).....	36
Total Reset (T RESEt).....	39
Setting Up Passwords (PASSwORD).....	41

Custom Menu (CUSTOM).....43
 System (SYSTEM).....44
 Serial Communications (COMM).....46
 Standby Mode (STANDBY).....46
Operation47
 Front Panel Buttons Operation47
 Grand Total Reading (Gr TOTAL).....48
 Previous Total & Grand Total.....48
 Display Max, Min & Previous Totals48
 Resetting the Total (RESET TOTAL)49
 Resetting the Grand Total (RESET Gr TOTAL)49
 Resetting Max/Min Readings (RESET MAXIMUM, MINIMUM).....49
 Reset Meter to Factory Defaults.....50
 Factory Defaults & User Settings.....50
Troubleshooting.....51
 Troubleshooting Tips.....51
Quick User Interface Reference.....52

Table of Figures

Figure 1. Enclosure Dimensions – Front View.....13
 Figure 2. Enclosure Dimensions – Side Cross Section View13
 Figure 3. Connector Board Mounted in Base of Enclosure14
 Figure 4. Connectors & Switches on Rear of Display Module.....14
 Figure 5. Flowmeter Powered by External Supply (Active)15
 Figure 6. Isolated Flowmeter Powered by External Supply (ISO)15
 Figure 7. Self-Powered Magnetic Pickup Coil Flowmeter (Coil).....15
 Figure 8. NPN Open Collector Input.....15
 Figure 9. PNP Sensor with External Power15
 Figure 10. Switch Contact Input (Reed).....15
 Figure 11. DC Power Connections15
 Figure 12. Reset Connections16
 Figure 13. 4-20 mA Output Connections16
 Figure 14. RS-485 2 Wire Serial Connections16
 Figure 15. RS-485 4 Wire Serial Connections16
 Figure 16. Open Collector Output Connections.....16
 Figure 17. Battery Orientation17
 Figure 18. Date Display Example.....44

Specifications

Except where noted all specifications apply to operation at +25°C.

General

Display	Top	Five digits, (0-99999), 0.7" (17.8 mm) high, 7- segment, automatic lead zero blanking.
	Bottom	Seven alphanumeric characters, 0.4" (10.2 mm) high, 14-segment, automatic lead zero blanking.
	Symbols	Total, grand total, battery power/low battery, high alarm, low alarm, SafeTouch button sleep mode/disable, password lock
Display Assignment	Top Display: Rate or total Bottom Display: Combinations of rate, total, grand total, units, and custom tag	
Backlight	White; it can be disabled/enabled in the Advanced - System menu. The backlight is automatically turned off below -20°C.	
Alarm Indication	Flashing display plus HI/LO (rate) or SET (total) indicators	
Display Orientation	Display may be mounted at 90° increments up to 270° from default orientation.	
Display Update Rate	Ambient > -20°C: 1 update/second Ambient < -20°C: 1 update/10 seconds <i>Note: Update is dependent on gate settings.</i>	
Overrange	Display flashes 99999	
Programming Method	Four SafeTouch through-glass buttons when cover is installed. Four internal pushbuttons when cover is removed. Free MeterView EX software.	
Recalibration	Recalibration is recommended at least every 12 months.	
Max/Min Display	Max/Min readings reached by the process are stored until reset by the user or until power to the meter is turned off.	
Password Menu Options	Three programmable password selections can be used for the following: restrict modification of settings, prevent resetting the total or grand total without the password, or permanently lock out the ability to change or reset the grand total or any grand total related settings (making a non-resettable grand total). Pass: Restricts modifications of programmed settings to require re-entering the password to make changes. Pass T: Restricts the reset of total to require re-entering the password. Disables the manual mode reset contact. Pass GT: Restricts the reset of grand total to require re-entering the password. May enable a non-resettable grand total and permanent lockout of grand total-related settings with a specific password.	
Power Options	9-30 VDC Powered, 2.2 W max	
	4-20 mA Output Powered, 30 VDC max	
	Battery Power	
	9-30 VDC Powered with Battery Backup	
	4-20 mA Output Powered with Battery Backup	

Battery	3.6 V Primary Lithium (Li-SOCI2), non-rechargeable Model PDABAT36C		
	Expected Service Life & Recommended Replacement Interval		
	Operating Condition	Estimated Service Life	Suggested Replacement Interval
	Open collector outputs off, SafeTouch buttons off, minimal backlight use	7.5 years	5.5 years
	<100 Hz open collector outputs, minimal SafeTouch button or backlight use	5.5 years	4 years
	<2 kHz open collector outputs, minimal SafeTouch button or backlight use	2.5 years	2 years
	<5 kHz open collector outputs, minimal SafeTouch button or backlight use	1.3 years	1 year
	Backup power only	N/A	10 years
Data Logging	Up to 1024 records, recorded 4/day at specific times or at defined time intervals. Record contains date, time, rate, total, grand total, and log number.		
Isolation	All Models:	500 V opto-isolated input-to-power/output with isolated input enabled	
	PD6830-BTA:	500 V input-to-output	
	PD6830-APA:	500 V input/power-to-output <i>Note: Requires separate output supply</i>	
Environmental	Operating temperature range: -40 to 75°C Storage temperature range: -40 to 75°C Backlight deactivated below temperatures ≈ -20°C Relative humidity: 0 to 90% non-condensing Printed circuit boards are conformally coated.		
Non-Volatile Memory	All programmed settings and total reading are stored in non-volatile memory for a minimum of ten years if power is lost.		
Connections	Screw terminals accept 12 to 22 AWG wire		

Enclosure	NEMA 4X, IP68 Explosion-proof die cast aluminum, 0.30% max copper content, corrosion resistant epoxy coating, Color: Blue Window: Glass Three 3/4" NPT threaded conduit openings. One 3/4" NPT nickel plated brass conduit plug with 12 mm hex key fitting installed.
Mounting	May be mounted directly to conduit. Two slotted flanges for wall mounting or NPS 1 1/2" to 2 1/2" or DN 40 to 65 mm pipe mounting. See <i>Dimensions</i> on page 13.
Overall Dimensions	5.65" x 5.25" x 4.86" (W x H x D) (144 mm x 133 mm x 124 mm)
Weight	5.00 lbs (80 oz, 2.27 kg)
Warranty	3 years parts and labor. See Warranty Information and Terms & Conditions on www.prediq.com for complete details.

Rate Input

Pulse/Transistor/Contact Closure Input	Field selectable; Sourcing or sinking pulse or square wave 0-5 V, 0-12 V, or 0-24 V; TTL; NPN or PNP transistor; Open collector 100 kΩ pull-up to 3 V; Switch contact 100 kΩ pull-up to 3 V; PNP transistor 100 kΩ pull-down to ground (COM) Active input 100 kΩ to battery level, 10 kΩ to power Maximum Frequency: 64 kHz Minimum Pulse Width: 5 μs Threshold Setting									
	<table border="1"> <thead> <tr> <th>Setting</th> <th>Low (V)</th> <th>High (V)</th> </tr> </thead> <tbody> <tr> <td>Normal</td> <td>1.2</td> <td>2.0</td> </tr> <tr> <td>Low</td> <td>0.2</td> <td>1.2</td> </tr> </tbody> </table>	Setting	Low (V)	High (V)	Normal	1.2	2.0	Low	0.2	1.2
Setting	Low (V)	High (V)								
Normal	1.2	2.0								
Low	0.2	1.2								
Opto-Isolated Input	Sourcing pulse or square wave 0-5 V, 0-12 V, or 0-24 V; Logic High: 2-24 V, Logic Low: < 1 V Maximum Frequency: 20 kHz Minimum Pulse Width: 20 μs Input Current: 1 mA @ 5 V, 2.5 mA @ 12 V, 5 mA @ 24 V									
Low Voltage Mag Pickup Input	Sensitivity: 20 mVp-p to 24 Vp-p Maximum Frequency: 6 kHz									
Minimum Input Frequency	0.0001 Hz. Minimum frequency is dependent on high gate setting (rate display).									
Input Impedance	Pulse input: Greater than 75 kΩ @ 1 kHz. Open collector/switch input: 100 kΩ pull-up to 3 V.									
Accuracy	±0.03% of calibrated span ±1 count									
Temperature Drift	Rate display is not affected by changes in temperature.									
Low-Flow Cutoff	0.1 to 99,999 or disable. Point below at which the display always shows zero.									
Decimal Point	Up to four decimal places or none: 4444, 33333, 22222, 11111, or 00000									
Calibration	May be calibrated using K-Factor, scale without signal source, or by applying an external calibration signal.									
K-Factor	Field programmable K-Factor converts input pulses to rate in engineering units. May be programmed from 0.000001 to 9,999,999 pulses/unit.									

Calibration Range	Input 1 signal must be ≥ 1 Hz; input 2 signal may be set anywhere above input 1 setting. Minimum input span is 1 Hz. An Error message will appear if the input 1 and input 2 signals are too close together.
Input Contact Debounce Filter	Programmable contact debounce filter. Input signal frequency speed selections of Hi (no filter), Med (250 Hz max input, 2 ms pulse width), and Low (100 Hz max input, 5 ms minimum pulse width).
Time Base	Second, minute, hour, or day
Gate	Low gate: 1-99 seconds; High gate: 2-9,999 seconds

Rate/Totalizer

Display Assignment	The Top display is assigned to rate or total. The Bottom display is programmable to display total; total and units; total and tag; total, total units, and rate units; grand total; grand total and grand total units; grand total and tag; grand total, grand total units, and rate units; rate units; rate; rate and total units; rate and rate units; rate and tag; rate units; total units; a custom tag; or be off (blank).
Rate Display Units	Gallons, liters, imperial gallons, cubic meters, barrels, bushels, cubic yards, cubic feet, cubic inches, liquid barrels, beer barrels, hectoliters, or custom.
Rate Display Time Base	Rate display may be calculated in terms of units per second, minute, hour, or day.
Total & Grand Total Display Units	Gallons, liters, imperial gallons, cubic meters, barrels, bushels, cubic yards, cubic feet, cubic inches, liquid barrels, beer barrels, hectoliters, or custom. Setting is independent for each.
Total & Grand Total Display Unit Multiplier	x1, x100 (h), x1000 (k), or x1,000,000 (M) multiplier (and prefix) applied to total or grand total display units. Setting is independent for each.
Total & Grand Total Decimal Point	Up to six decimal places or none: 66666666, 55555555, 44444444, 33333333, 22222222, 11111111 or 00000000 Total and grand total decimal points are independently programmed, and are independent of rate decimal point.
Totalizers	Calculates total and grand total based on rate and field programmable multiplier to display total in engineering units. Time base must be selected according to the time units in which the rate is displayed. The total and grand total utilize the same time base, with different conversion factors and resets.
Totalizer Reset	Via SafeTouch RESET button, mechanical button (cover off), external contact closure (total only), automatically via user selectable preset value and time delay (1 – 99,999 sec). Manual reset may be disabled or protected by password for the total and grand total. Total and grand total reset independently.

Total Overflow And Rollover	The total can display up to 9,999,999,999,999. Up to 9,999,999 can be displayed on the lower display normally. An overflow display will toggle between the first six digits and last seven digits (999999 <> 9999999) for a 13-digit total. The total will rollover beyond thirteen digits. The T indicator on the display will flash to indicate total overflow, and the six most significant digits (first six numbers of the total) are indicated with the flashing overflow symbol $\overline{\cdot}$.
Grand Total Overflow And Rollover	The grand total can display up to 9,999,999,999,999. Up to 9,999,999 can be displayed on the lower display normally. An overflow display will toggle between the first six digits and last seven digits (999999 <> 9999999) for a 13-digit total. The grand total will rollover beyond thirteen digits. The GT indicator on the display will flash to indicate grand total overflow, and the six most significant digits (first six numbers of the grand total) are indicated with the flashing overflow symbol $\overline{\cdot}$.
External Total Reset	External total reset connections are made between RST and COM. Logic High: 1.4 V, 3.3V max; Logic Low: < 0.8 V. 32 ms debounce.

4-20 mA Transmitter Output

Output Source	Rate/process, total, grand total, or disabled		
Scaling Range	4.000 to 20.000 mA for any display range.		
Disable	If disabled, the output will output 3.2 mA		
Calibration	Factory Calibrated: 0.0 to 1000.0 = 4- 20 mA output		
Underrange	Output Underrange: 3.8 mA		
Overrange	Display Overrange: 20.5 mA Output Overrange: 20.5 mA		
Accuracy	$\pm 0.05\%$ of calibrated span ± 0.004 mA		
Temperature Drift	0.08 $\mu\text{A}/^\circ\text{C}$ max from -40 to 75°C ambient		
External Loop Power Supply	30 VDC maximum		
Output Loop Resistance	Power Supply	Minimum	Maximum
	24 VDC	10 Ω	750 Ω
	30 VDC	100 Ω	1100 Ω
	<i>Note: loop-powered backlight subtracts 150 Ω from maximum resistance figures above.</i>		

Open Collector Output

Output Assignment	Two open collector pulse outputs Out 1 and Out 2. Individually programmable for rate, total, or grand total alarms; rate, total, or grand total pulse outputs; or retransmitting of pulse inputs; constant timed pulse output; quadrature outputs (requires Out 1 and Out 2); or off.
Rating	Isolated open collector, sinking NPN 30 VDC @ 150 mA max.
Alarm Output	Assign to rate for high or low alarm trip point. Assign to total or grand total for total or grand total alarms.
Alarm Deadband	0-100% FS, user selectable
Alarm Acknowledge	Front panel ENTER button resets output and screen indication.
Pulse Output (Count)	The InvK-Factor (COUNT) is programmable from 0.000001 to 9999999. Total and grand total pulses are generated for every total or grand total increment selected. (e.g. InvK-Factor = 100 gal/p will generate one pulse every time the total is incremented by 100 gallons). Rate pulses are generated as a scaled output of the input frequency with one output pulse per InvK-Factor (COUNT). Rate retransmission outputs one pulse per one input pulse, up to the maximum output speed.
InvK-Factor = Volume/Pulse	
Pulse Output Pulse Width	Unless otherwise stated, pulses are 50% duty cycle for required frequency. A pulse rate retransmit output will generate 100 to 130 μs pulses at the falling edge of every input pulse.
Pulse Output Maximum Frequency	5 kHz, pulse width at 50% duty cycle. If the programming of the outputs would exceed 5 kHz, the meter will display PULSE OVERRNG
Quadrature Output	Output set to quadrature will lag the other pulse output by 90° (1/4 duty cycle) at output frequency. Minimum 1 Hz
Timer Output	Programmable On and Off time, repeating cycle. Minimum On time: 0.01 second, maximum On time: 10,000 seconds. Minimum Off time (Delay Period): 0.1 second, maximum Off time (Delay Period): 100,000 seconds. Delay Period: Countdown time delay (Off) after start is pressed. On Time: Time the open collector stays on.

Serial Communications

Protocol	Modbus® RTU
Meter Address/ Slave Id	1 - 247
Baud Rate	1,200; 4,800; 9,600; 19,200; 38,400; 57,600; or 115,200 bps
Transmit Time Delay	Programmable between 0 and 199 ms
Parity/Stop Bit	Even, odd, none with 1 stop bit, or none with 2 stop bits
Byte-To-Byte Timeout	Max of 1.5 character times or 750 μs

Note: Refer to Modbus Register Tables at www.predig.com for details.

MeterView EX Programming Software

System Requirements	Windows® 7/8/10 (Windows 32-bit or 64-bit operating systems)
Communications	PDA8068 Meter-to-USB Adapter, PDA7485-I RS-232 to RS-485 Isolated Converter (Cable not included), PDA8485-I USB to RS-485 Isolated Converter (Cable not included).
Protocol	Modbus RTU
Meter Address	1-247
Baud Rate	1200 bps to 115,200 bps
Configuration	Configure one meter at a time. File format: Saved as ".mve". Printing: Configuration can be printed.
Data Logging Report	Saved as ".csv" file format.

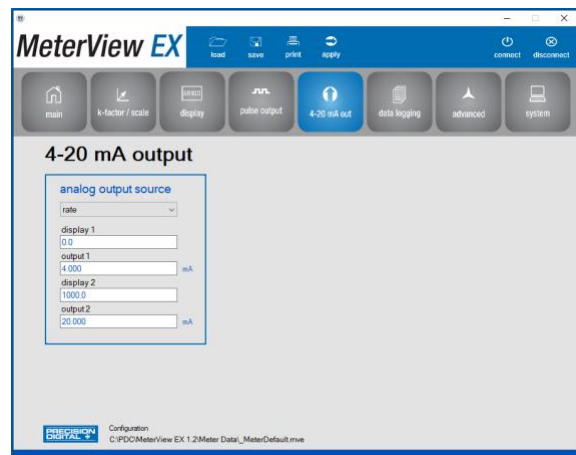
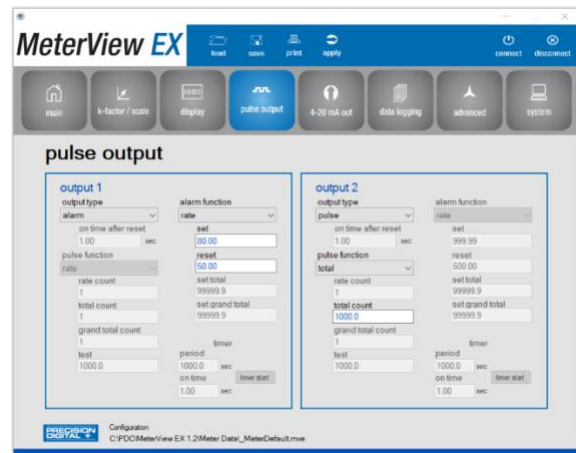
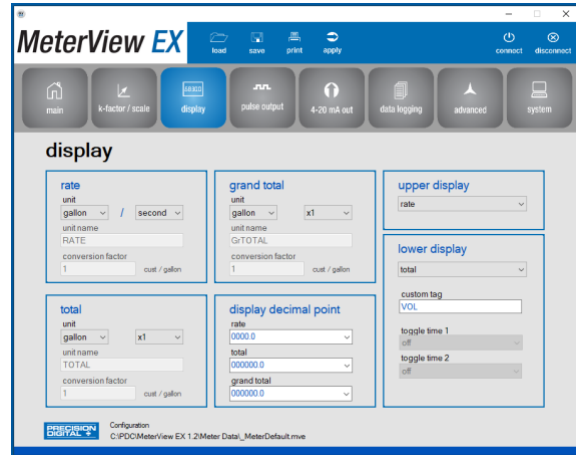
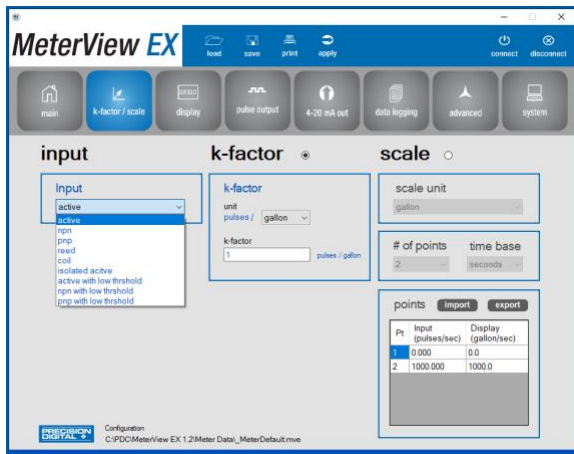

For detailed programming software instructions or to download MeterView EX software, visit predig.com/meterview-ex.

Product Ratings and Approvals

FM	Explosion-proof for use in: Class I, Division 1, Groups B, C and D Dust-ignition proof for use in: Class II/III, Division 1, Groups E, F and G; T6 Flame-proof for use in: Class I, Zone 1, AEx d Group IIC; T6 Protection by Enclosure: Zone 21, AEx tb IIIC; T85°C Ta = -40 to 75°C. Enclosure: Type 4X, IP66. Certificate number: 3040391
CSA	Explosion-proof for use in: Class I, Division 1, Groups B, C and D Dust-ignition proof for use in: Class II/III, Division 1, Groups E, F and G; T6 Flame-proof for use in: Zone 1, Ex d IIC T6 Ta = -40 to 75°C. Enclosure: Type 4X & IP66/IP68. Certificate number: 2325749
ATEX	 II 2 G D. Flame-proof for use in: Zone 1, Ex d IIC T6 Gb Protection by Enclosure for use in: Dust Atmospheres (Zone 21) Ex tb IIIC T85°C Db IP68. Ta = -40°C to +75°C Certificate number: Sira 10ATEX1116X
IECEX	Flame-proof for use in: Zone 1, Ex d IIC T6 Gb Protection by Enclosure for use in: Dust Atmospheres (Zone 21) Ex tb IIIC T85°C Db IP68. Ta = -40°C to +75°C Certificate number: IECEX SIR 10.0056X

Special Conditions for Safe Use:

Use suitably certified and dimensioned cable entry device and/or plug. The equipment shall be installed such that the supply cable is protected from mechanical damage. The cable shall not be subjected to tension or torque. If the cable is to be terminated within an explosive atmosphere, then appropriate protection of the free end of the cable shall be provided.

Year of Construction:

This information is contained within the serial number with the first four digits representing the year and month in the YYMM format.

For European Community:

The PD6830 must be installed in accordance with the ATEX directive 2014/34/EU, and the product certificate Sira 10ATEX1116X.

Electromagnetic Compatibility

Emissions	EN 61326-1 Safety requirements for measurement, control, and laboratory use – Industrial Group 1 Class A ISM emissions requirements EN55022 Class A ITE emissions requirements EN61000-6-4 Emissions for heavy industrial environments - Generic
Radiated Emissions	Class A
Immunity	EN 61326-1 Measurement, control, and laboratory use – Industrial EN61000-6-2 Immunity for heavy environments - Generic
ESD	±4 kV contact, ±8 kV air
RFI – Amplitude Modulated	80-1000 MHz @ 10 V/m, 1.4-2.0 GHz @ 3 V/m, 2.0-2.7 GHz @ 1 V/m, 80% AM (1 kHz)
EFT	±2 kV DC mains, ±1 kV other
Telco Surge	±1 kV
CRFI	3 V, 0.15-80 MHz, 1 kHz 80% AM
Power Frequency Magnetic Field	30 A/m 70% V for 0.5 period

EU Declaration of Conformity

EU Declaration of Conformity is available in the Documentation CD provided with the product under the **EU DoC** menu.

Safety Information

WARNINGS

- Read complete instructions prior to installation and operation of the meter.
- Installation and service should be performed only by trained service personnel. Service requiring replacement of internal components (not including battery, if equipped) must be performed at the factory.
- Disconnect from supply before opening enclosure. Keep cover tight while circuits are alive. Conduit seals must be installed within 18" (450mm) of the enclosure.
- Verify that the operating atmosphere of the meter is consistent with the appropriate hazardous locations certifications.
- If the meter is installed in a high voltage environment and a fault or installation error occurs, high voltage may be present on any lead.

Installation

For Installation in USA: The PD6830 must be installed in accordance with the National Electrical Code (NEC) NFPA 70.

For Installation in Canada: The PD6830 must be installed in accordance with the Canadian Electrical Code CSA 22.1.

For European Community: The PD6830 must be installed in accordance with the ATEX directive 2014/34/EU and the product certificate Sira 10ATEX1116X.

WARNING

- Installation and service should be performed only by trained service personnel. Service requiring replacement of internal components must be performed at the factory.
- Disconnect from supply before opening enclosure. Keep cover tight while circuits are alive. Conduit seals must be installed within 18" (450mm) of the enclosure.

Wiring connectors are accessed by opening the enclosure. To access electrical connectors, remove the two captive screws, then disconnect the ribbon cable from the display module and set the display module aside.

Unpacking

Remove the meter from box. Inspect the packaging and contents for damage. Report damages, if any, to the carrier.

If any part is missing or the meter malfunctions, please contact your supplier or the factory for assistance.

Pre-Installed Conduit Plug

The PD6830 typically includes three 3/4" NPT threaded conduit openings and one 3/4" NPT metal conduit plug with 12 mm hex key fitting installed. Additional conduit opening configurations and plugs may be available; verify quantity and sizes on specific device labeling during installation. The pre-installed plug and its installation are included in the hazardous area approvals for the PD6830.

The conduit/stopping plug included in a typical PD6830 has an internal 12 mm hexagonal socket recess for removal.

WARNING

- In hazardous areas, conduit and conduit/stopping plugs require the application of non-setting (solvent free) thread sealant. It is critical that all relevant hazardous area guidelines be followed for the installation or replacement of conduit or plugs.

Battery Activation Pull Tab

PD6830 models with battery or battery backup power will include a battery activation pull-tab. This tab assures the meter is not operational during shipment or storage and is located with the battery. Remove this tab during installation of the meter.

Mounting

The PD6830 has two slotted mounting flanges that may be used for pipe mounting or wall mounting. Alternatively, the unit may be supported by the conduit using the conduit holes provided.

Refer to *Figure 1* and *Figure 2*.

WARNING

- Do not attempt to loosen or remove flange bolts while the meter is in service.

Dimensions

All units: inches [mm]

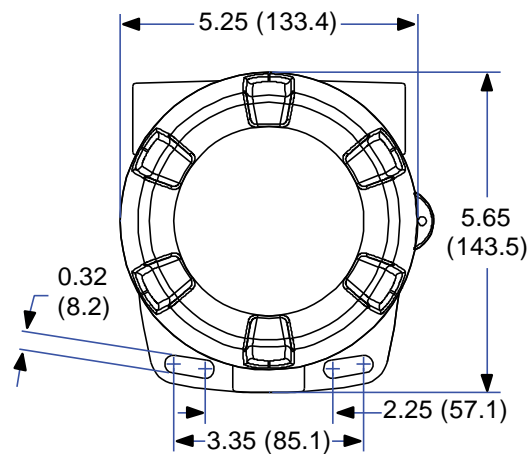

Figure 1. Enclosure Dimensions – Front View

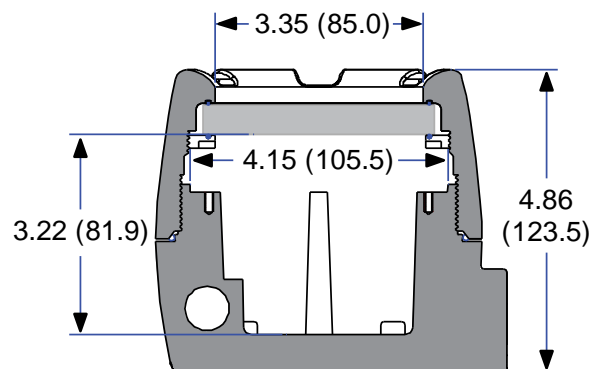

Figure 2. Enclosure Dimensions – Side Cross Section View

ENCLOSURE CAD DIMENSIONAL DRAWINGS

Download free 3-D CAD files of these instruments to simplify your drawings!

predig.com/documentation-cad

Cover Jam Screw

The cover jam screw should be properly installed once the meter has been wired and tested in a safe environment. The cover jam screw is intended to prevent the removal of the meter cover in a flameproof environment without the use of tools. Using a M2 hex wrench, turn the screw clockwise until the screw contacts the meter. Turn the screw an additional ¼ to ½ turn to secure the cover. Caution: Excess torque may damage the threads and/or wrench.

Connections

To access the connectors, loosen the cover jam screw (if tightened) with an M2 hex wrench, remove the enclosure cover and unscrew the two captive screws that fasten the display module into the enclosure. Disconnect the ribbon cable and remove the display module.

RS-485 serial connections are made to a removable terminal block on the back of the display module. Power and signal connections are made to a screw terminal connector in the base of the enclosure. Grounding connections are made to the two ground screws provided on the base – one internal and one external. Use proper grounding techniques for explosion-proof areas and observe all local and national electric codes.

S+	Input signal positive terminal connection
S-	Input signal negative terminal connection
COM	DC power supply input return/negative, reset contact closure common
RST	Contact closure reset pull-up to 1.8 VDC
P+	DC Power positive terminal connection
LP+	4-20 mA transmitter DC power positive terminal connection.
LP-	4-20 mA transmitter regulated current output terminal connection
OC1+	Open collector output 1 positive terminal
OC1-	Open collector output 1 negative terminal
OC2+	Open collector output 2 positive terminal
OC2-	Open collector output 2 negative terminal

Refer to *Figure 3* and *Figure 4* for terminal positions.

⚠ WARNINGS

- Observe all safety regulations. Electrical wiring should be performed in accordance with all agency requirements and applicable national, state, and local codes to prevent damage to the meter and ensure personnel safety.
- Static electricity can damage sensitive components.
- Observe safe handling precautions for static-sensitive components.
- Use proper grounding procedures/codes.
- If the meter is installed in a high voltage environment and a fault or installation error occurs, high voltage may be present on any lead or terminal.

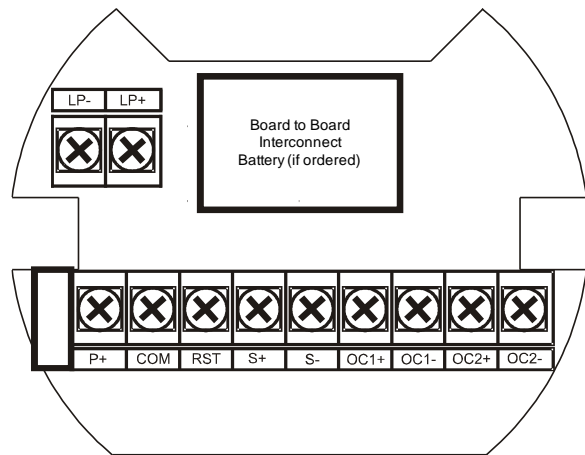

Figure 3. Connector Board Mounted in Base of Enclosure

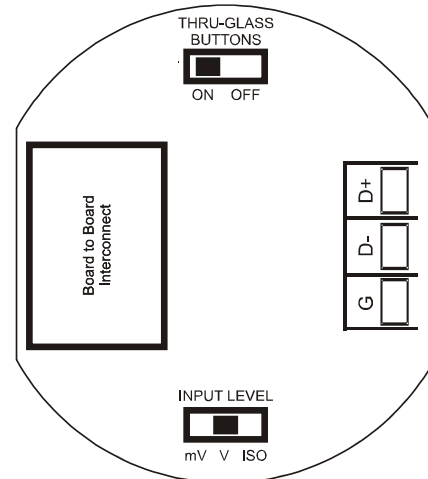

Figure 4. Connectors & Switches on Rear of Display Module

Wiring Diagrams

Input Signal Connections

Signal connections are made to a barrier terminal mounted in the base of the enclosure. Input level and type are configured using the slide switches on the bottom of the display module as shown in the lower right of the following figures.

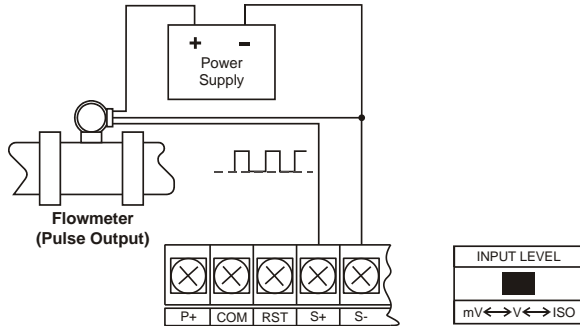

Figure 5. Flowmeter Powered by External Supply (Active)

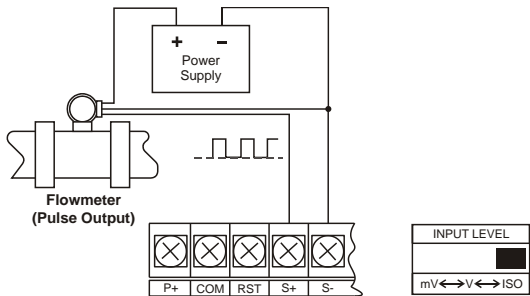

Figure 6. Isolated Flowmeter Powered by External Supply (ISO)

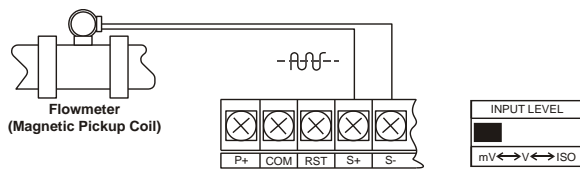

Figure 7. Self-Powered Magnetic Pickup Coil Flowmeter (Coil)

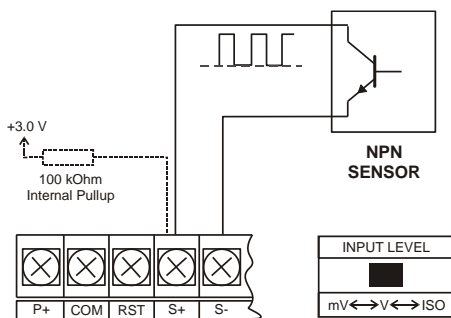

Figure 8. NPN Open Collector Input

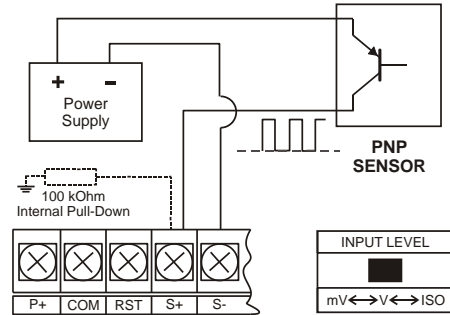

Figure 9. PNP Sensor with External Power

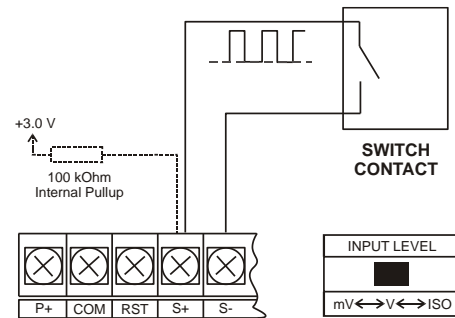

Figure 10. Switch Contact Input (Reed)

DC Power Connection

Models configured for DC power (PD6830-A) are provided with a terminal labeled P+ and are wired as shown in Figure 11. Models configured for battery power (PD6830-B) may optionally be connected to DC power and the battery will function as backup power when DC is lost. The same power supply may be used to power other circuits including a PNP-type sensor, however, to maintain input isolation, a separate power supply must be used to power the isolated 4-20 mA transmitter as shown in Figure 13 and/or to power the Opto-Isolated Flowmeter as shown in Figure 6.

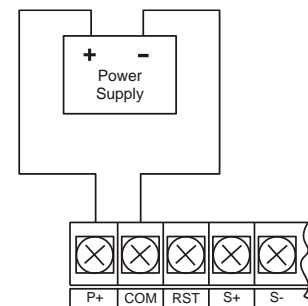

Figure 11. DC Power Connections

External Total Reset Connection

External total reset connections are made between RST and COM. Connect to a contact closure source such as a relay or a pushbutton as shown in *Figure 12*. Avoid extended contact closure to preserve battery life. The total is reset when the button is pressed. The meter will start to totalize immediately. Holding down the button has no effect on the total.

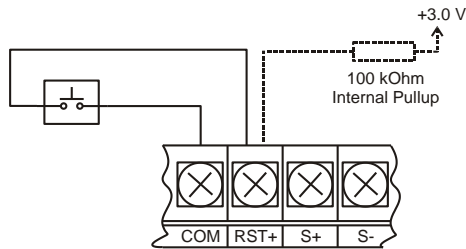

Figure 12. Reset Connections

4-20 mA Transmitter Output Connections

Output connections are made to two terminals labeled LP+ and LP-. Connect to an input device such as a remote display or chart recorder as shown in *Figure 13*.

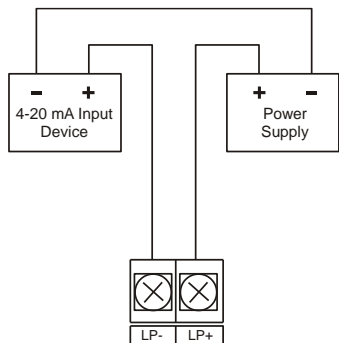

Figure 13. 4-20 mA Output Connections

RS-485 Serial Connections

The meter may include an optional RS-485 two-wire serial connection. The cabling used for an RS-485 serial communications network should always be a high quality cable such as Belden 8162 or Alpha 6203C. A two-wire system requires two twisted pairs, and a four-wire system requires three twisted pairs (the extra twisted pair is needed for the signal ground).

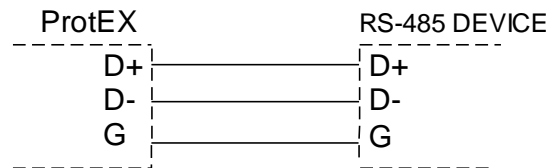

Figure 14. RS-485 2 Wire Serial Connections

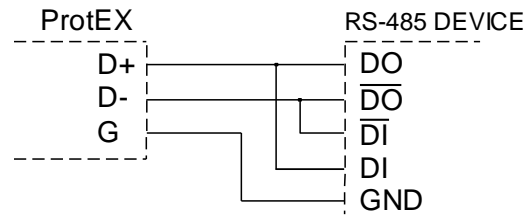

Figure 15. RS-485 4 Wire Serial Connections

Open Collector Output Connections

Open collector output 1 and 2 connections are made to terminals labeled OC1+ and OC1-, and OC2+ and OC2-. Connect the alarm or pulse input device as shown in *Figure 16*.

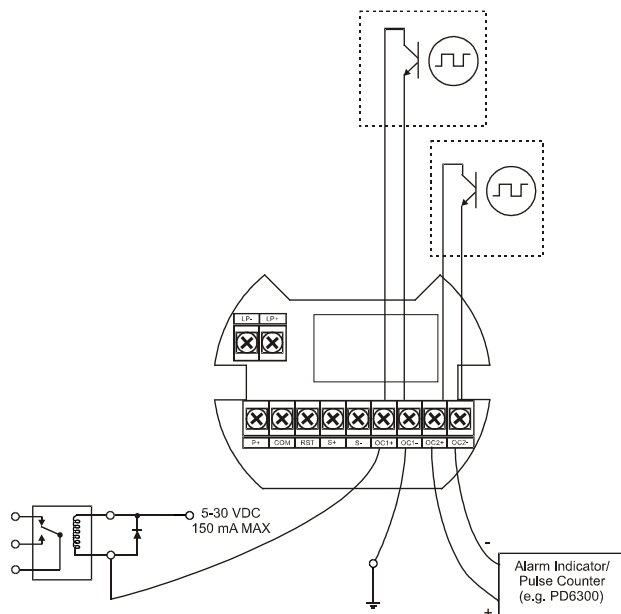

Figure 16. Open Collector Output Connections

Battery Replacement

Battery-equipped models have a battery charge monitor. When the battery is nearing the end of its capacity the screen will periodically flash the message **LO BATTERY** and the BAT indicator on the screen will flash. The recommended replacement interval for models using the battery as a primary power source is determined by the power and feature use, as shown on page 7. The battery should be replaced when the low battery indication is on the screen.

The total is backed up in non-volatile memory when the low battery monitor is tripped. It is recommended that an updated reading be manually backed up prior to changing out the battery.

⚠ WARNINGS

- Fire, explosion, and burns may result if not handled properly. Do not recharge, short circuit, crush, disassemble, heat above 100°C (212°F), incinerate, or expose contents to water.
- Battery disposal should be in accordance with applicable regulations, which vary by location. In many locations trashing of used batteries is forbidden and disposal is done through local battery disposal facilities. Spent batteries should be packaged in such a way as to prevent short circuits during handling and transport.



NOTICE: Battery may only be replaced with an original Model **PDABAT36C** supplied by Precision Digital. Do not recharge battery. Do not replace with used battery.

- Remove cover and display module and disconnect display module ribbon cable.
- Carefully cut and remove the cable ties supplied for shipping (if present).
- Remove the spent battery and prepare it for disposal.
- Install new PDABAT36C into battery clip with polarity as shown in Figure 17.
- Reconnect and fasten display module. Install enclosure cover.
- Resume operation.

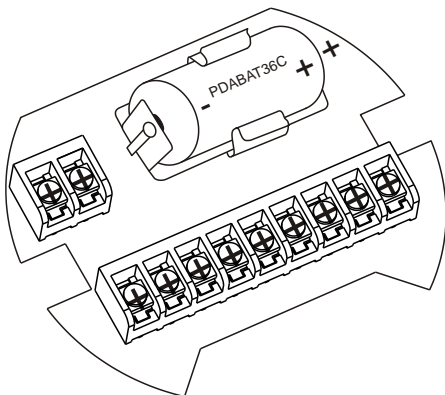

Figure 17. Battery Orientation

Setup and Programming

There is **no need to recalibrate** the meter for frequency in Hz when first received from the factory.

The meter is **factory calibrated** for Hz prior to shipment. The calibration equipment is traceable to NIST standards.

Overview

Setup and programming is done through the infrared through-glass SafeTouch buttons, using the mechanical buttons when uncovered, or with MeterView EX programming software. There are two slide switches located on the display module. One is used to configure the input and the other is to lock or unlock the SafeTouch Buttons.

MeterView EX Programming Software



The fastest and easiest way to program the meter is using the free MeterView EX programming software. This software greatly simplifies the programming process and allows the user to save configuration files for later use.

The MeterView EX software requires the [PDA8068](#) USB Serial Adapter, [PDA7485-I](#) RS-232 to RS-485 Isolated Converter, or the [PDA8485-I](#) USB to RS-485 Isolated Converter to connect the PC to the meter.



To download the MeterView EX programming software, visit predig.com/meterview-ex.

SafeTouch Buttons

The PD6830 is equipped with four sensors that operate as through-glass buttons so that it can be programmed and operated without removing the cover (and exposing the electronics) in a hazardous area. These buttons can be disabled for security by setting the THRU-GLASS BUTTONS switch located on the back of the display module to OFF.

SafeTouch Button Operation

To actuate a button, press and remove one finger to the glass directly over the marked button area. Remove finger to at least 4 inches away from the window in between button activations. SafeTouch and mechanical buttons may be held to cycle through menus or digits in place of repeatedly pushing a button.



SafeTouch Power Save Mode

SafeTouch buttons enter a power saving mode after three minutes of inactivity. This mode is indicated by the SafeTouch power symbol (⏻) appearing in the lower right of the display. Only the **MENU** button is monitored in this mode. To activate the SafeTouch buttons, press and hold the menu button for up to five seconds. The display will read **AWAKE**, and the SafeTouch buttons will be fully enabled.

SafeTouch Disabled Mode

When the cover is removed, the four mechanical buttons located next to the sensors may be used. The sensors are disabled when a mechanical button is pressed and will automatically be re-enabled after 60 seconds of inactivity. The SafeTouch power symbol (⏻) will blink in the lower right of the display if the buttons are disabled due to a mechanical pushbutton being pressed.

IMPORTANT

- SafeTouch will not work if two or more buttons are detected as being pressed simultaneously. Be careful to avoid triggering multiple buttons or reaching across one button location to press another.

SafeTouch Button Tips and Troubleshooting

The SafeTouch Buttons are designed to filter normal levels of ambient interference and to protect against false triggering, however it is recommended that the SafeTouch Buttons be turned off (slide THRU-GLASS BUTTONS switch located on the back of the display module to OFF) if there is an infrared interference source in line-of-sight to the display or if the buttons are not needed.

SafeTouch Button Tips:

- To the extent possible, install the display facing away from sunlight, windows, reflective objects and any sources of infrared interference.
- Keep the glass window clean.
- Tighten the cover securely.
- Use a password to prevent tampering.
- If the cover has not been installed and secured tightly, it may take a moment for the SafeTouch buttons to properly self-calibrate when the cover is tightened.

After all connections have been completed and verified, connect the ribbon cable to the display module, fasten the display module to the base, install enclosure cover, and then apply power.

SafeTouch Button Equalize Delay

The SafeTouch buttons are designed to constantly recalibrate for ambient conditions. When the cover position is changed, the cover is removed, or an object is removed that was placed over the front window, it may take a moment for the SafeTouch buttons to recalibrate to the change in conditions.

Allow up to 2 minutes for the SafeTouch buttons to recalibrate to new conditions in these cases where the cover position was changed, or the front window is being unblocked.

Buttons and Display



Button Symbol	Description
	Menu / SafeTouch Awake
	Right Arrow / Reset
	Up Arrow / Display
	Enter / Alarm Ack

Symbol	Status
HI	High Alarm
LO	Low Alarm
SET	Total Alarm
	Settings Lockout Password Enabled
	SafeTouch Power Save/Disable. Flashing: Temporarily Disabled Due to Mechanical Button
T	Total Display Flashing: Total Overflow Indication
GT	Grand Total Display Flashing: Total Overflow Indication
	13 Digit Total Overflow, 6 Most Significant Digits
BAT	Flashing: Low Battery Indicator Steady: Powered by Battery Backup

Menu Button

- Hold the **Menu** SafeTouch button when in power save mode (display will show) to awaken SafeTouch buttons.
- Press the **Menu** button to enter Programming Mode.
- Press the **Menu** button during Programming Mode to return to the previous menu selections.
- Hold the **Menu** button for 1.5 seconds at any time to exit Programming Mode and return to *Run Mode*.
- Press and hold the **Menu** button for 3 seconds to access the *Advanced Features* of the meter.

Right / Reset Button

- Press the **Right** arrow button to move to the next digit or decimal position during programming.
- Press **Right** to go forward through most selection menus.
- Press **Reset** to reset the total, or values displayed in the bottom display (grand total, max, or min). Press **Enter** after **Reset** to confirm the reset.

Up / Display Button

- Press **Display** when in Run Mode to display the grand total, again to display the maximum, and again to display the minimum reading since last reset. These displays will time out in 12 seconds, or press **Display** until total is displayed in the lower display. Press **Enter** to lock this display, and disable the 12 second time out.
- Press the **Up** arrow button to scroll forward through the menus, decimal point, or to increment the value of a digit.

Enter Button

- Press the **Enter** button to access a menu or to accept a setting.
- Press **Enter** to lock display of grand total, Max or Min readings (disables 10 second timeout).
- Press **Enter** while the grand total, max, or min reading is locked on the lower display to return to run mode.
- Press **Enter** to acknowledge alarm (if enabled).

Setting Numeric Values

The numeric values are set using the **Right** and **Up** arrow buttons. Press **Right** arrow to select next digit and **Up** arrow to increment digit.

The digit being changed blinks.

Press the **Enter** button, at any time, to accept a setting or **Menu** button to exit without saving changes.

The decimal point is set using the **Right** or **Up** arrow button in the *Setup*, *Decimal Point* menu.

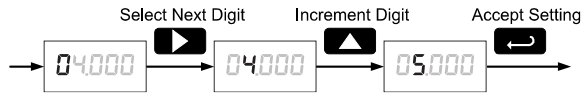

Setting Alphanumeric Labels (LAbEL)

Fully alphanumeric values are set using the **Right** button to select the digit, the **Up** and **Right** arrow buttons to select the digit reading, and the **Enter** button to confirm and select the next digit.

Menus using this entering method will display *LAbEL* in the upper display. After selecting the digit, and using the **Up** and **Right** arrows to modify the digit, the display will read *CHAr*. Using **Enter** to confirm the new digit will return the display to reading *LAbEL*.

The digit being changed blinks.

Press the **Menu** button to exit without saving changes.

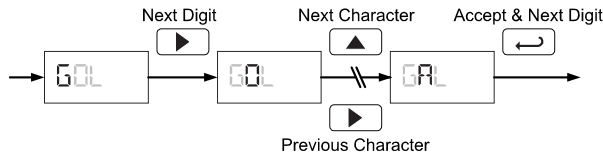

Main Menu

The main menu separates the most commonly used functions in the *Setup menu*, and more complex features in the *Advanced Features* menu.

Press **Menu** button to enter Programming Mode then press the **Up** arrow button to scroll through the main menu.

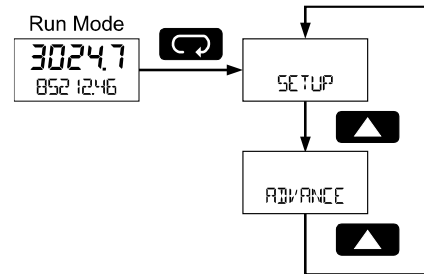

- Press **Menu**, at any time, to return to the previous menu selection. Press and hold the **Menu** button for 1.5 seconds at any time to return to Run Mode.
- Changes to the settings are saved to memory only after pressing **Enter**.
- The display moves to the next menu every time a setting is accepted by pressing **Enter**.

Setup Menu Display Functions & Messages

The meter displays various functions and messages during setup, programming, and operation. The following table shows the main menu functions and messages in the order they appear in the menu.

Display	Parameter	Action/Setting
SETUP	Setup	Enter Setup menu
Input	Input	Enter Input type selection menu
Active	Active	Set active input type
NPN	NPN	Set NPN input type
PNP	PNP	Set PNP input type
Reed	Reed	Set reed switch input type
Coil	Coil	Set coil input type
Isolated	Isolated	Set isolated input type
Active low	Active low	Set active input type with low threshold
NPN low	NPN low	Set NPN input type with low threshold
PNP low	PNP low	Set PNP input type with low threshold
K-Factor	K-Factor	Enter the K-Factor menu
K-Factor units	K-Factor units	Enter the K-Factor units
P/GAL	Pulses/gallon	Set K-Factor in pulses per gallon
P/L	Pulses/liter	Set K-Factor in pulses per liter
P/IGAL	Pulses/imp gallon	Set K-Factor in pulses per imperial gallon
P/M ³	Pulses/meter ³	Set K-Factor in pulses per meter cubed
P/BBL	Pulses/barrel	Set K-Factor in pulses per barrel
P/BUSH	Pulses/bushel	Set K-Factor in pulses per bushel
P/cu yd	Pulses/cubic yard	Set K-Factor in pulses per cubic yard
P/cu ft	Pulses/cubic feet	Set K-Factor in pulses per cubic foot
P/cu in	Pulses/cubic inch	Set K-Factor in pulses per cubic inch
P/L BBL	Pulses/liquid barrel	Set K-Factor in pulses per liquid barrel
P/BBL	Pulses/beer barrels	Set K-Factor in pulses per beer barrel
P/HECTL	Pulses/hectoliter	Set K-Factor in pulses per hectoliter
P/CUST	Pulses/custom	Set K-Factor custom unit

Display	Parameter	Action/Setting
dEcPt	K-Factor decimal point	Set the number of decimal points in the K-Factor
K-Factor	K-Factor value	Set the K-Factor for custom units
Units	Units	Select standard units or custom unit/tag
Rate time base	Rate time base	Enter the Time Base menu
SEC	Second	Units per second
MIN	Minute	Units per minute
hour	Hour	Units per hour
DAY	Day	Units per day
Rate units	Rate units	Select rate display units
GAL	Gallons	Set units as gallons
L	Liters	Set units as liters
IGAL	Imperial gallons	Set units as imperial gallons
M ³	Meters cubed	Set units as cubic meters
BBL	Barrels	Set units as barrels
BUSH	Bushels	Set units as bushels
cu yd	Cubic yards	Set units as cubic yards
cu ft	Cubic feet	Set units as cubic feet
cu in	Cubic inches	Set units as cubic inches
L BBL	Liquid barrels	Set units as liquid barrels
BBL	Beer barrels	Set units as beer barrels
HECTL	Hectoliter	Set units as hectoliters
CUST	Custom unit	Use a custom unit
User	User	Set a custom unit
LABEL	Label	Select a custom unit label character
CHAR	Character	Set a character in a custom unit label
Rate conversion factor	Rate conversion factor	Enter the Rate Conversion Factor menu
Total units	Total units	Select total display units
Total multiplier	Total multiplier	Select the total units multiplier
x1 (no multiplier)	x1 (no multiplier)	Select no multiplier
x100 (h)	x100 (h)	Select x100 multiplier with h unit prefix
x1000 (k)	x1000 (k)	Select x1,000 multiplier with k unit prefix
x1.0*10 ⁶ (M)	x1.0*10 ⁶ (M)	Select x1,000,000 multiplier with M prefix
Total conversion factor	Total conversion factor	Enter the Total Conversion Factor menu

Display	Parameter	Action/Setting
ጊደቲህ	Grand total units	Select grand total display units
ጠገሊት	Grand total multiplier	Select the grand total units multiplier
ግጥርፎ	Grand total conversion factor	Enter the Grand Total Conversion Factor menu for custom units
dፎርፑት	Decimal point	Enter Decimal Point menu
ጥገደ	Rate decimal	Set rate display decimal point
ጠባይ	Total decimal	Set total display decimal point
ግጥር	Grant total	Set grand total display decimal point
dSፑሊሃ	Display	Set the function of the top and bottom displays
ጠባይ	Top	Set the function of the top display
ጥገደ	Rate	Display rate
ጠባይ	Total	Display total
ቆይታ	Bottom	Set the function of the bottom display
ጠባይ	Total	Display total
ጠባይ	Toggle	Toggle between the values shown in the bottom display
TOTALፀህ	Total & units	Display total and units
TOTALፀገ	Total & Tag	Display the total and custom tag
TOTALፀህ	Total & units & rate units	Display the total, total units, and rate units
ግጥር	Grand total	Display grand total
ግጥር ፀህ	Grand total & units	Display grand total and units
ግጥር ፀገ	Grand total & tag	Display the grand total and custom tag
ግጥር ፀህ	Grand total & units & rate units	Display the grand total, grand total units, and rate units
ጥገደ	Rate	Display the rate
RATEፀህ	Rate & total units	Display the rate and total units
RATEፀህ	Rate & units	Display the rate and rate units
RATEፀገ	Rate & tag	Display the rate and custom tag
ጥገደ	Rate unit	Display the rate units
ጠባይ	Total units	Display the total units
ጠገ	Custom tag	Enter the custom tag to be displayed

Display	Parameter	Action/Setting
ፀፈፈ	Off	Turn off the bottom display
ጠገ ጊደ	Tag Time	Set time to display custom tag
ህንጻ ጊደ	Unit Time	Set time to display lower display unit
ጥገደ ጊደ	Rate Unit Time	Set time to display rate unit

Setting Up the Meter (SETUP)

The Setup menu is used to select:

1. Input type selection (*inፑሊት*)
2. K-Factor number and units (*ፍጥር*)
3. Display rate, total, and grand total units (*ህንጻ*)
4. Rate and total decimal point position (*dፎርፑት*)
5. Select what will appear on the lower display (*dSፑሊሃ*)

Press the **Enter** button to access any menu or press **Up** arrow button to scroll through choices. Press the **Menu** button to back out of a menu, or hold the **Menu** button to exit at any time.

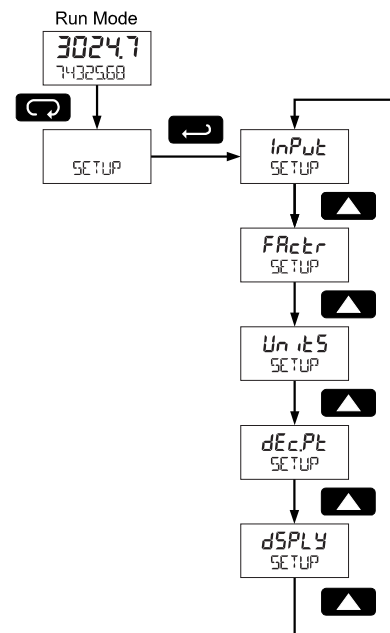

Selecting Input Type (*inPut*)

Seven input types may be set. See *Rate Input* specifications on page 8 for electrical specifications of the inputs.

The following input types may be selected:

Active (Act iU)

Active square wave pulse inputs

NPN (nPN)

Internal pull-up resistor on S+ for NPN inputs

PNP (PNP)

Internal pull-down resistor on S+ for PNP inputs

Reed (rEEd)

Internal pull-up resistor on S+ for switch inputs

Coil (CO IL)

Magnetic coil flowmeter inputs (input selector switch must be set to mV)

Isolated active input (.5o)

Active square wave isolated pulse inputs (input selector switch must be set to ISO)

Active with low threshold (ActLD)

Active square wave pulse inputs with a low threshold

NPN with low threshold (nPNLD)

Internal pull-up resistor on S+ for NPN inputs with a low threshold

PNP with low threshold (PNPLD)

Internal pull-down resistor on S+ for PNP inputs with a low threshold

Input Level Selection Switch

In addition to programming the *inPut* parameter, the input selector switch shown below must also be set. Input voltage level selections include mV, V and isolated inputs.

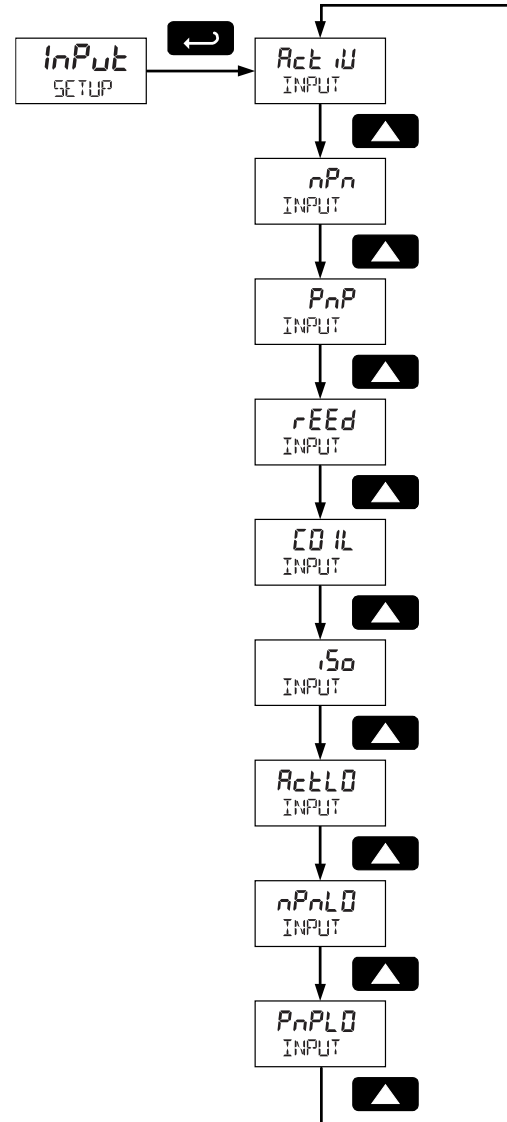
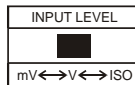

See *Rate Input* specifications on page 8 for electrical specifications of the inputs.
 See *Input Signal Connections* on page 15 for details on wiring the input types.

Entering the K-Factor (FRctr)

The meter may be scaled using the *K-Factor*, or conversion factor, function. Most flowmeter manufacturers provide this information with the device. Enter the *K-Factor* (FRctr) menu and select the units defined with the K-Factor (example: pulses/gal), the decimal point with highest resolution possible, and program the K-Factor value. The meter will automatically calculate the flow rate using the K-Factor and the units and time base selected.

IMPORTANT

- Performing a K-Factor operation will override any scaling or calibration programming. Refer to *Scaling & Calibration (SCALCAL)* on page 36 for more information on these programming methods.

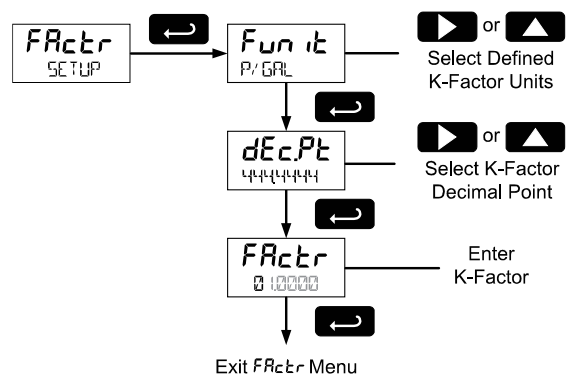

K-Factor Units (Funit)

Select the units defined with the K-Factor (example: pulses/gal). This is usually provided by the flowmeter manufacturer. This does not set the rate display units, and only relates to entering the K-Factor. To set or change the rate display units, see *Setting the Rate Display Units (rAtEU)* on page 25.

The K-Factor unit may be a custom unit (CUST).

Automatic unit conversions are not performed when the K-Factor unit is set to custom. See page 27 for information on the *Automatic Unit Conversions* feature.

K-Factor Decimal Point (dEcPt)

Set the number of decimal places necessary to enter the K-Factor value. The decimal point may be set with up to six decimal places or with no decimal point at all. Pressing the **Right** arrow moves the decimal point one place to the right (including no decimal point). Pressing the **Up** arrow moves the decimal point one place to the left.

K-Factor Value (FRctr)

Enter the K-Factor value. This value is entered in Pulses/Unit as defined by the *K-Factor Units* parameter. Most flowmeter manufacturers provide this information with the device.

Display Units (Units)

The *Units* menu is used to select the display rate units and time (example: Gal/s) and the display units for total and grand total.

IMPORTANT

- The units selected in this menu are the desired display units only. The units defined by the K-Factor of a flow meter are entered in the K-Factor menu as part of the Factor Unit menu programming. See *K-Factor Units (Funit)* on page 24 for details.
- This allows the display units to be different than the units defined by the flow meter, or be changed easily after initial programming. Unit conversions for rates and totals are performed automatically by the meter. See *Automatic Unit Conversions* on page 27 for details.

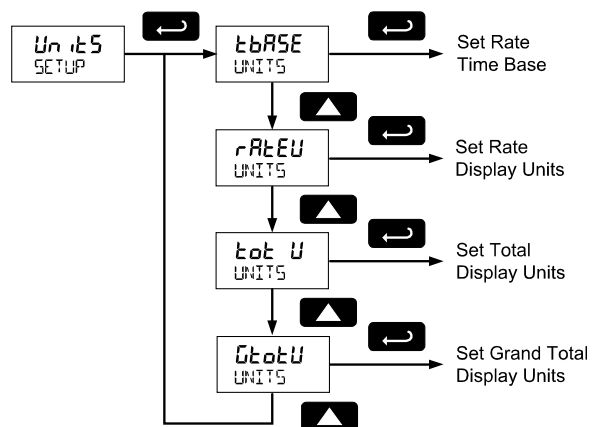

The following units may be selected as the base units for rate, total, and grand total. Time base for rate and a multiplier for total and grand total units may also be selected separately.

Setting the Time Base (tBASE)

The meter calculates rate based on rate time base and rate display units. The time base is the unit of time used to calculate the rate, and can be set as units per second, minute, hour, or day.

Press the **Enter** button, at any time, to accept a setting or **Menu** button to exit without saving changes.

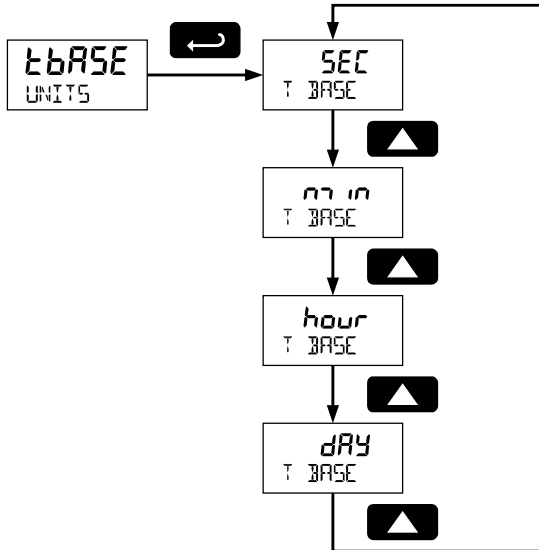

Setting the Rate Display Units (rRtEU)

Rate is displayed in terms of a unit of volume, and a time base. The unit selected will be used with the time base to establish the rate unit (example: GAL/S when Units is GAL, and time base is seconds).

The custom unit selection (CUST) will require the custom unit to be entered by the user. See *Custom Units Rate Conversion Factor (rRtCF)* on page 27.

Press the **Enter** button, at any time, to accept a setting or **Menu** button to exit without saving changes.

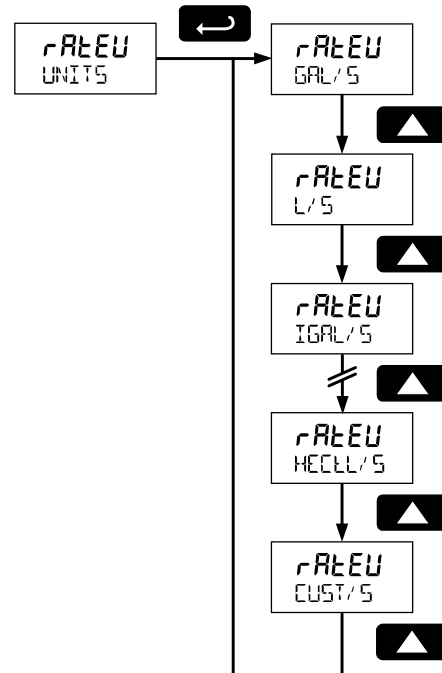

Total Units (טוט U)

This menu is used to select the display units for the total. The base unit and a multiplier prefix are selected. If total and units are selected to display, the multiplier prefix will appear before the total unit (example: MGAL, KL).

Multipliers will convert the total for 1, 100, 1000, or 1 million units. The meter will calculate the total appropriately for display with the programmed multiplier and units.

A custom unit may be selected (CUST), and no multiplier menu will be required. In this case, use the total conversion factor as defined in *Custom Units Total Conversion Factor (טוטCF)* on page 27.

Press the **Enter** button, at any time, to accept a setting or **Menu** button to exit without saving changes.

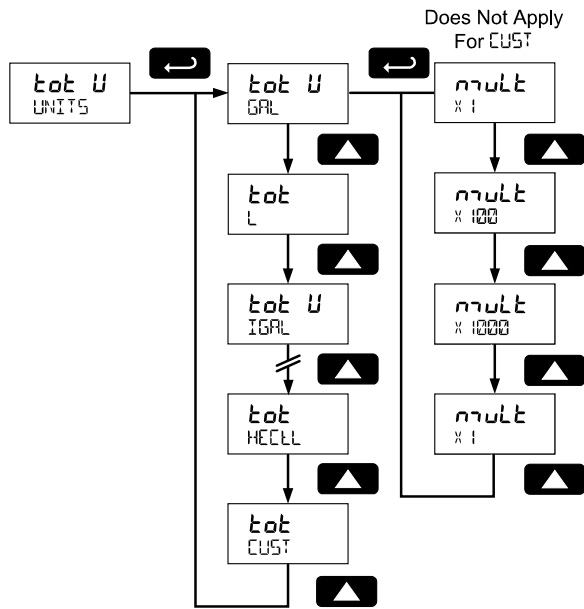

Grand Total Units (גטוטU)

This menu is used to select the display units for the grand total. The base unit and a multiplier prefix are selected. If grand total and units are selected to display, the multiplier prefix will appear before the total unit (example: MGAL, KL).

Multipliers will convert the total for 1, 100, 1000, or 1 million units. The meter will calculate the total appropriately for display with the programmed multiplier and units.

A custom unit may be selected (CUST), and no multiplier menu will be required. In this case, use the grand total conversion factor as defined in *Custom Units Grand Total Conversion Factor (גרטוטCF)* on page 27.

Press the **Enter** button, at any time, to accept a setting or **Menu** button to exit without saving changes.

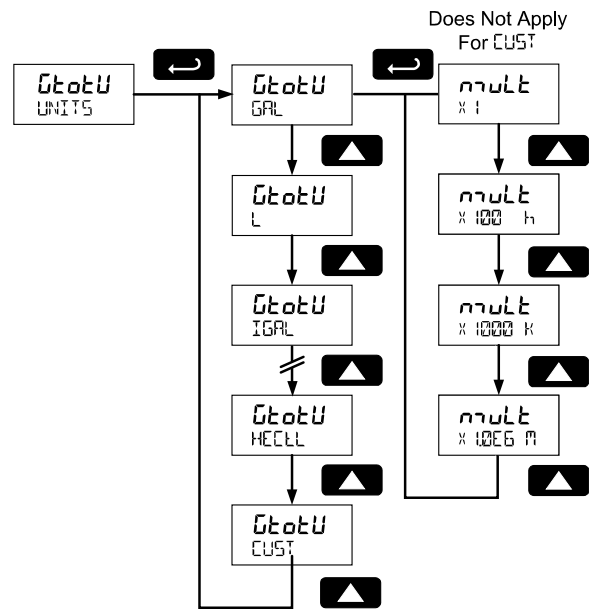

Automatic Unit Conversions

When switching from any standard unit of rate, total, or grand total to any other standard unit, automatic unit conversions are performed by the meter.

No unit conversions will be performed when the K-Factor Units (*F_{UNIT}*) menu is set to custom (*CUST*).

A total or grand total unit conversion will automatically change the displayed total and grand total to the equivalent volume of the newly selected unit.

Custom Units Entry (*USER*)

When a custom unit is selected for rate, total, or grand total, a *User* menu allows for entry of the custom unit.

Any 5-digit 14-segment unit may be entered for a custom rate unit (example: mL).

Any 7-digit 14-segment unit may be entered for a custom total or grand total unit (examples: GALLONS, BOTTLES, DRUMS).

When selected for total or grand total, a custom unit will not allow a multiplier prefix. A custom total or grand total unit will allow a total or grand total conversion factor to be entered to define the unit. See *Custom Units Total Conversion Factor* (*TotCF*) on page 27 for details.

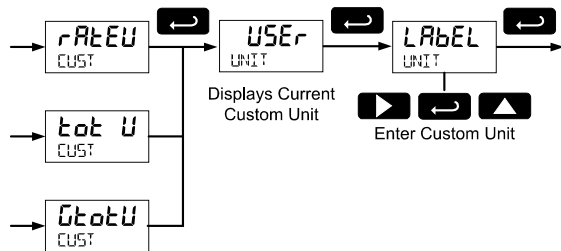

Fully alphanumeric values are set using the **Right** button to select the digit to be changed. Press the **Up** button to begin editing the digit, then the **Up** and **Right** arrow buttons to select the next or previous alphanumeric character. Press the **Enter** button to confirm and select the next digit to change.

For details on setting alphanumeric labels, refer to *Setting Alphanumeric Labels* (*LABEL*) on page 20.

Press **Menu** button to exit this menu without saving changes.

Custom Units Rate Conversion Factor (*rRateCF*)

The rate conversion factor is only used when the *Units* for rate have been set to custom (*CUST*). This menu will not appear if standard display units are selected for the rate unit.

Rate Conversion Factor is used to convert to a custom unit of rate display. For example, to display rate as quantity of 2.5 gallon containers when the K-Factor units are set to gallons, enter a conversion factor of 2.500.

Press the **Enter** button, at any time, to accept a setting or **Menu** button to exit without saving changes.

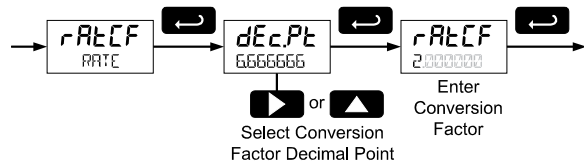

Custom Units Total Conversion Factor (*TotCF*)

The total conversion factor is only used when the *Units* for total have been set to custom (*CUST*). This menu will not appear if standard display units are selected for total.

Total Conversion Factor is used to convert to a custom unit of total display. For example, to display total as quantity of 2.5 gallon containers when the K-Factor units are set to gallons, enter a conversion factor of 2.500.

Press the **Enter** button, at any time, to accept a setting or **Menu** button to exit without saving changes.

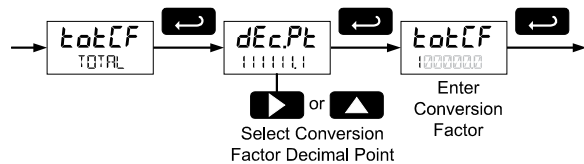

Custom Units Grand Total Conversion Factor (*GrTotCF*)

The grand total conversion factor is only used when the *Units* for grand total have been set to custom (*CUST*). This menu will not appear if standard display units are selected for grand total.

Grand Total Conversion Factor is used to convert to a custom unit of total display. For example, to display grand total as quantity of 2.5 gallon containers when K-Factor units are set to gallons, enter a conversion factor of 2.500.

Press the **Enter** button, at any time, to accept a setting or **Menu** button to exit without saving changes.

Setting the Decimal Point (dEc.Pt)

Rate decimal point may be set with up to four decimal places or with no decimal point at all. Total decimal point may be set with up to six decimal places or with no decimal point at all. Grand total decimal point may be set with up to six decimal places or with no decimal point at all. Rate decimal, total decimal, and grand total decimal are programmed individually.

Pressing the **Right** arrow moves the decimal point one place to the right (including no decimal point). Pressing the **Up** arrow moves the decimal point one place to the left.

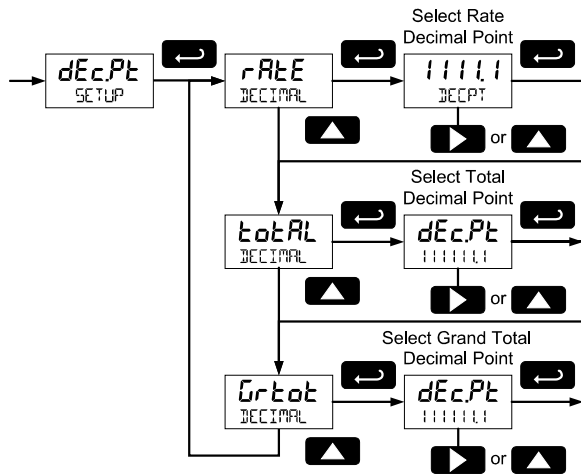

Advanced Features Menu

To simplify the setup process, functions not needed for most applications are located in the *Advanced Features* menu. Access the Advanced features menu by pressing **Enter** at the *Advance* menu in the *Main Menu* defined on page 20.

The *Advanced Features* menu is used to select:

1. Open collector output configuration (OUTPUT)
2. Analog output configuration (A OUT)
3. Gate function for low speed inputs (GATE)
4. Set the input filter (FILTER)
5. Set low flow cutoff (CUTOFF)
6. Scale or live calibrate the meter and override K-Factor (SCALECAL)
7. Select method of total and grand total reset (T RESET)
8. Set passwords (PASSWORD)
9. Reconfigure the *Main* menu structure (CUSTOM)
10. Enter the *System* menu for meter settings and data logging (SYSTEM)
11. Configure serial communication settings (COMM) – if applicable
12. Enter low-power Standby Mode (STANDBY) on battery powered models

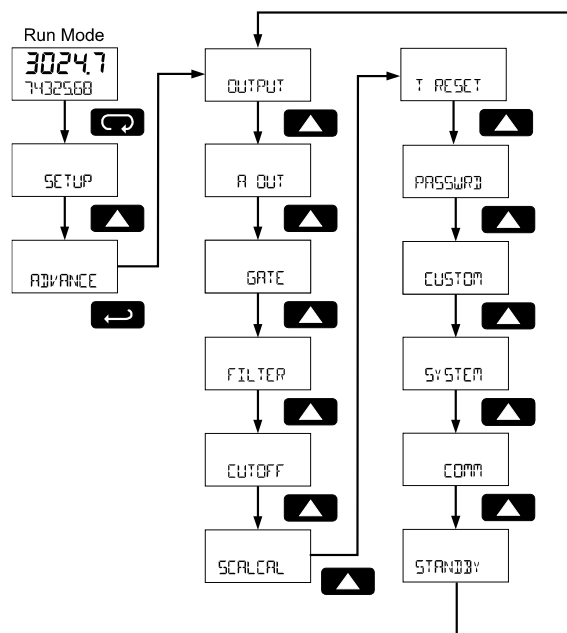

Advanced menus *A OUT* displayed only for meters with the analog output option, *COMM* displayed only for meters with the serial communications option, and *STANDBY* only for meters with battery or battery backup power.

Press the **Enter** button to access any menu or press the **Up** arrow button to scroll through choices. Press the **Menu** button to back out of a menu, or hold the **Menu** button to exit at any time.

Advanced Features Menu & Display Messages

The following table shows the *Advanced* features menu functions and messages in the order they appear in the menu.

Display	Parameter	Action/Setting
ADVANCE	Advanced	Enter <i>Advanced</i> menu
OUTPUT	Output	Setup open collector outputs Out 1 and Out 2
OUT 1	Output 1	Assign function of open collector output 1
OUT 2	Output 2	Assign function of open collector output 2
PULSE	Pulse	Set Out 1 or Out 2 for pulse output mode
rate	Rate	Assign pulse output to rate
total	Total	Assign pulse output to total
Grand	Grand total	Assign pulse output to grand total
decPt	Decimal point	Set K-Factor decimal point
count	Count	Set K-factor
reTr	Retransmit	Assign pulse output to retransmit
quad	Quadrature	Assign pulse output to quadrature
test	Test	Assign pulse output to test mode
ALarm	Alarm	Assign Out 1 or Out 2 for alarm output mode
rate	Rate	Assign alarm output to rate
set	Set point	Set rate alarm set point
reset	Reset point	Set rate alarm reset point
total	Total	Assign alarm output to total
Grand	Grand total	Assign alarm output to grand total
set	Set point	Set total or grand total alarm set point
On	On	Set output to on state
Off	Off	Set output to off state
timer	Timer	Set Out 1 or Out 2 for timed pulse output mode
start	Start	Activate timed pulse output
delay	Delay	Set the time of one period (seconds)
On	On	Set the active low pulse width
Off	Off	Set Out 1 or Out 2 as off
A OUT	Analog Output	Enter <i>Analog Output</i> menu
rate	Rate output	Set rate as output variable

Display	Parameter	Action/Setting
TOTAL	Total output	Set total as output variable
GrTot	Grand total output	Set grand total as output variable
dSP 1	Display 1	Output display 1 value
OUT 1	Output 1	Output 1 value
dSP 2	Display 2	Output display 2 value
OUT 2	Output 2	Output 2 value
SAVEP	Save	Save entered analog parameters
dSAbL	Disable	Turn off the analog output
GATE	Gate	Enter Gate menu
LO	Low gate	Set Low Gate
HI	High gate	Set High Gate
FILTER	Filter	Enter Filter menu
HI	High speed filter	Set high speed filter
Med	Medium speed filter	Set medium speed filter
LO	Low speed filter	Set low speed filter
CUTOFF	Low-flow cutoff	Enter Low-Low Cutoff menu
SCALECAL	Scale & calibrate	Enter the Scale & Calibrate menu to program without using a K-Factor
SCALE	Scale	Enter the Scale menu
CAL	Calibrate	Enter the Calibrate menu
Undo ^P KFACTOR	Undo K-factor	Undo the K-Factor input programming
Undo ^P SCALECAL	Undo scaling & calibration	Undo the scaling and calibration input programming
no ^P	No	Do not undo other programming
YES ^P	Yes	Undo other programming
noPTS	Number of points	Enter the number of scaling or calibration points
inP 1	Input 1	Calibrate or scale input 1 value
dSP 1	Display 1	Program display 1 value
inP 2	Input 2	Calibrate or scale input 2 value
dSP 2	Display 2	Program display 2 value
SAVEP	Save	Save entered calibration or scale parameters
T RESET	Total reset	Enter the Total Reset menu
TrSt	Total reset	Select the Total Reset method
Man	Manual	Manual total reset
EnAbL	Enable	Enable manual reset
dSAbL	Disable	Disable manual reset
Auto	Automatic	Automatic total reset

Display	Parameter	Action/Setting
T DELAY	Time delay	Automatic reset time delay Note: This setting is activated when the total reaches an output set point, it can be used for simple batch operations.
TrSt	Total Reset Time	Enter the time of day to reset the total hh.mm (Default: 00.00 midnight)
SET CLOCK	Set Clock	Message indicates that the clock must be set. Go to Advance – System – Set Time
GrSt	Grand total reset	Select the Grand Total Reset method
PASSWD	Password	Enter the Password menu
PASS	Password	Program password to lock meter parameters
PASS T	Password total	Program password to prevent total reset
PASS GT	Password grand total	Enter password to permanently lock out grand total related parameters and reset
UnLOC	Unlock	Password has been unlocked
LOCd	Lock	Password has been locked
UNLOCKD	Unlocked	Program password to lock meter
LOCKED	Locked	Enter password to unlock meter
CUSTOM	Custom	Enter Custom menu
POS 1	Position 1	Set menu position 1 (1-8)
POS 8	Position 8	Set menu position 8
SYSTEM	System	Enter System menu
SETTIME	Set time	Set real-time clock date and time
YEAR	Year	Set the year
MONTH	Month	Set the month
01	January	Set month as January
02	February	Set month as February
03	March	Set month as March
04	April	Set month as April
05	May	Set month as May
06	June	Set month as June
07	July	Set month as July
08	August	Set month as August
09	September	Set month as September
10	October	Set month as October
11	November	Set month as November
12	December	Set month as December
DAY	Day	Set the day

Display	Parameter	Action/Setting
TIME	Time	Set the hour and minute
DATALOG	Data log	Enter Data Log menu
LOGTIME	Log time	Set daily data log times
LOG 1	Log 1	Set first daily log time (1-4)
dSAbL	Disable	Disable log number
INTERVL	Interval	Set interval log time
StArT	Start	Begin interval logging
LOGVIEW	Log view	View data log
ALL LOGVIEW	All log view	View all data log points
LOG NUM	Log number	Go to specific log number
ALL ERASE	All erase	Erase all logs
ErASE?	Erase?	Confirm to erase all logs
BACKLITE	Backlight	Enable or disable backlight
dSAbL	Disable	Disable backlight
EnAbL	Enable	Enable backlight
AO CAL	Analog output calibration	Enter Analog Output Calibration menu
BACKUP	Backup	Enter Backup menu
SAVE?	Save?	Save current parameters to backup restore
LOAD?	Load?	Load parameters from backup restore
dEFLt	Default	Restore factory default parameter settings
rESEt	Reset defaults	Confirm factory reset
REFACTSP	Reset defaults	Confirm factory reset
BAL SYM	Battery symbol	Enter Battery Symbol menu
dSAbL	Disable	Disable battery symbol
EnAbL	Enable	Enable battery symbol
INFO	Info	Enter Info menu
SOFT	Software	Display software ID number
VER	Version	Display software version number
Model	Model	Display model number
COMM	Communications	Enter Communications menu
Modbus	Modbus	Enter Modbus communications menu
SLV ID	Slave ID	Set Modbus slave ID
BAUD	Baud rate	Set baud rate
DELAY	Transmit delay	Set transmit delay time
PARITY	Parity	Set parity and stop bits
STANDBY	Standby	Enter standby mode (battery powered only)
YES?	Yes	Confirm standby mode

Open Collector Outputs (OUTPUT)

The meter is equipped with two NPN open collector outputs that may be set up for pulse outputs, alarms, timed pulses, or turned off.

Pulse outputs are based on rate, total or grand total counts, or one-for-one retransmit for input pulses. Both outputs may be used to generate a quadrature output based on any output type. An output test mode can be used to generate pulses at a constant programmable frequency.

Alarms are available based on the rate, total, or grand total. The alarm status will show on the display even if the output is not wired. The outputs may also be forced on or off.

A timed pulse output generates constant pulses at a specified frequency and on time.

A total reset output generates a pulse whenever the selected total or grand total is reset, regardless of the reset method used. The On time is programmable between 0.10 and 99,999.99 sec.

The output may be disabled by selecting OFF.

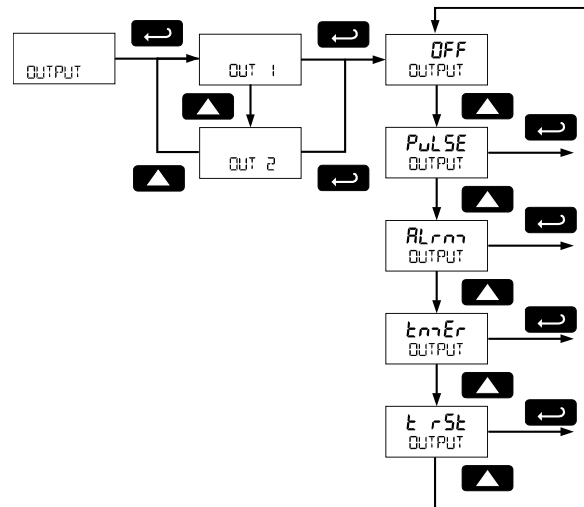

Output 1 and 2 Setup (OUT 1, OUT 2)

The function of open collector output 1 and 2 is configured using the *Off, Pulse, Alarm, Timer, and Total Reset* menus detailed below.

Pulse Output (PULSE)

Pulse outputs may be assigned to rate, total, grand total, retransmit, quadrature, or test.

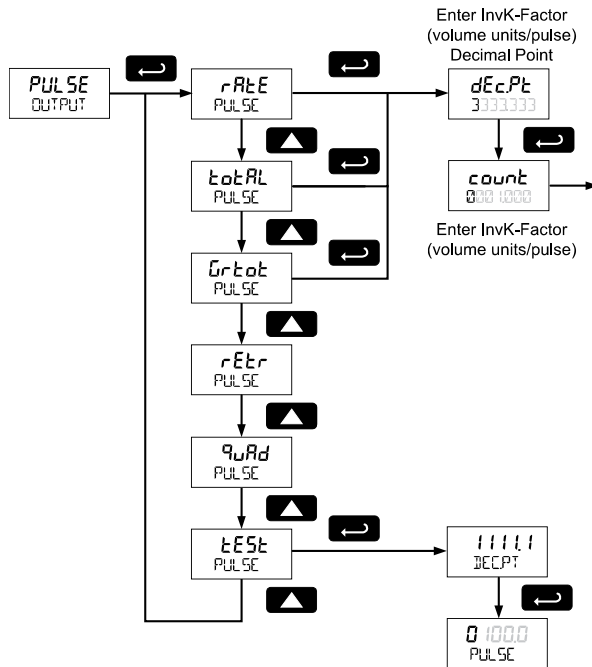

Total & Grand Total Pulse Output (tOtAL, GrTot)

A total and grand total based pulse output is a factor of the associated total and count (output InvK-Factor). A pulse will be generated for every total accumulation amount equal to the count.

If the maximum output frequency is exceeded, the meter displays the message *PULSE OVERRNG* alternating on the display.

Retransmit Output (rEtE)

The retransmitting pulse output will send an output pulse for every input pulse, essentially duplicating the input signal. The output will generate a pulse at the falling edge of every input pulse.

No additional programming is required for a retransmitting pulse output.

If the maximum output frequency is exceeded, the meter displays the message *PULSE OVERRNG* alternating on the display.

Quadrature Output (QuAd)

The pulse output set to quadrature will duplicate the other open collector output, but lag by ¼ duty cycle (90 degrees out of phase). For example, Out 1 will follow Out 2, if Out 1 is set to quad. Only one output should be set to quad. If both outputs are set to quad, both outputs will be disabled. The other output should be programmed as desired for the quadrature output function, and must be a pulse (*PULSE*) output selection.

Rate Pulse Output (rRtE)

A rate based pulse output is a factor of the input frequency and the Count (InvK-Factor). The rate display is a factor of the input pulses, time base, and the input K-Factor. The rate of output pulses over one time base (seconds, minutes, hours, days) is defined below in terms of input pulses, the input K-Factor, and the Count (InvK-Factor) parameters.

$$\text{Number of Output Pulses} = \frac{\left(\frac{\text{Input Frequency}}{\text{Input K-Factor}} \right)}{\text{Count (InvK-Factor)}}$$

Example:
 Input = 1000 pulses/sec
 K-Factor = 10 pulses/gallon
 Rate = 100 gallons/sec
 Count (InvK-Factor) = 100 gallons/pulse
 (Inverse K-Factor = Volume units/pulse)
 Pulse Output = 1 pulse/sec

Test Output (tEt)

The test output setting programs the output to generate pulses at a programmed constant frequency. Set the frequency decimal point location in the *DEC Pt* menu, and then enter the desired output frequency in Hz in the *PULSE* menu.

Alarm Output (ALr)

Alarm outputs may be assigned to rate, total, or grand total; or be forced on or off.

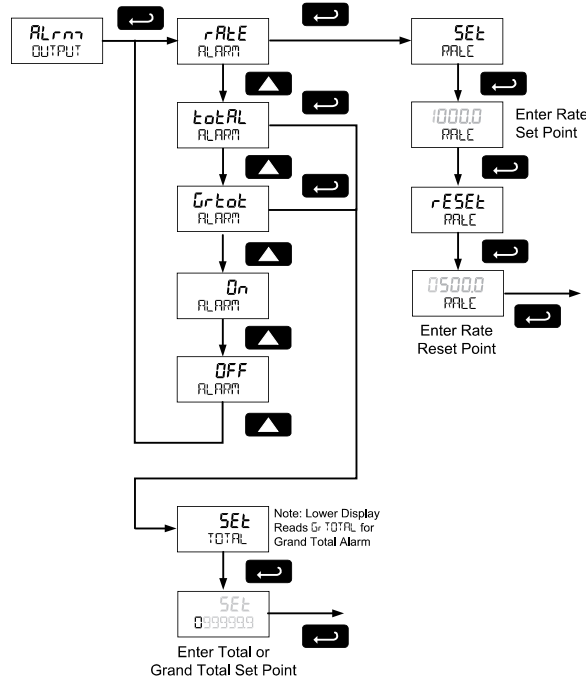

Force On State (On)

This alarm mode forces the output to be active, or on. This mode is primarily used to test alarm systems.

Force Off State (OFF)

This alarm mode forces the output to be inactive, or off. This mode is primarily used to test alarm systems.

Timer Output (tEr)

The timer output produces a constant width pulse at a constant rate. Program the *Delay Period* from 0.1 to 999999.9 seconds (time from the start of one pulse to the start of the next pulse). Program the *On Time* for the active low pulse from .01 to 99999.99 seconds (pulse width). The *on* time must be less than the delay time. Select *Start* to begin outputting the constant timed pulse. Select *Stop* to end outputting the constant timed pulse.

Total Reset Output (t rSt)

A total reset output generates a pulse whenever the selected total or grand total is reset, regardless of the reset method used. Program the *On Time* from 0.10 to 99,999.99 seconds. This is the amount of time the open collector output will remain on after the total or grand total has been reset.

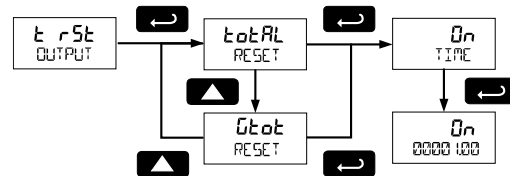

Rate Alarm (rALt)

Program the rate *set point* to trigger the alarm. Rate alarm deadband is determined by the difference between set and reset points. Minimum deadband is one display count. If set and reset points are programmed the same, output will reset one count below set point.

Total or Grand Total Alarm (tOtAL, GrtOtAL)

Program total or grand total *set point*. A pulse alarm is generated when the *set* value is reached by the total or grand total.

If the total/grand total is set for manual reset, this alarm will remain until the total/grand total is reset to 0.

If automatic total/grand total reset is enabled, the output will generate an alarm for a period of time programmed in *ADVANCE* → *T RESET* → *Auto* → *T DELAY*. After this time delay, the total/grand total will reset to 0 and the alarm will clear.

If Out 1 and Out 2 are set for total or grand total alarm, the auto reset will be triggered on the highest of the two alarm set points.

For details on setting the total or grand total automatic reset time delay, see *Total Reset (T RESEt)* on page 39.

Scaling the 4-20 mA Analog Output (A_{OUT})

The *Analog Output* menu is used to program the 4-20 mA output based on display values.

The 4-20 mA analog output (if equipped) can be scaled to provide a 4-20 mA signal for any display range selected for either the rate, total, or grand total. The output may be disabled (*d5RbL*) and will only output the minimum signal.

No equipment is needed to scale the analog output; simply program two display values and corresponding mA output signals.

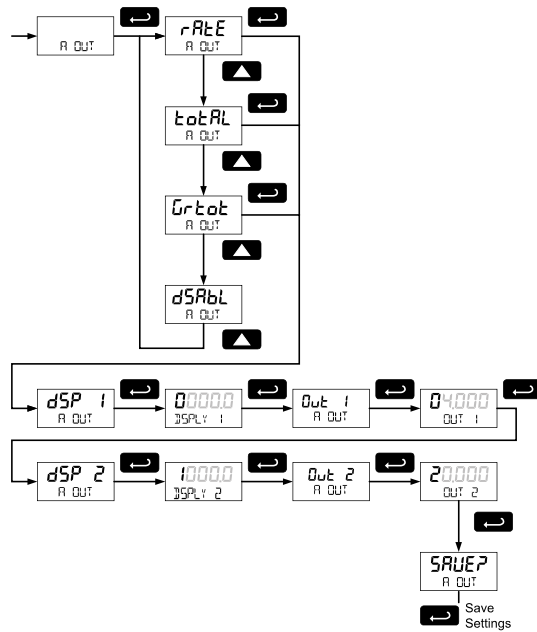

- CAUTION**
- Please note that when power is removed from the meter, the analog output will drop below 1 mA.
 - Take this effect into consideration when designing any system using the 4-20 mA output.

Gate Function (GATE)

The gate function is used for displaying slow pulse rates. Using the programmable gate, the meter can display pulse rates as slow as 1 pulse every 9,999 seconds (0.0001 Hz). The gate function can also be used to obtain a steady display reading with a fluctuating input signal.

There are two settings for the *GATE*, low gate (*L0*) and high gate (*H1*).

Low Gate (L0 GATE)

For most applications, low gate setting should be left at 1 second. Increase low gate setting to obtain a steadier rate display. The rate display will update in accordance with the low gate setting, for example if low gate is set at 10, the display will update every 10 seconds; changes in rate between updates will not be reflected until next display update.

High Gate (H1 GATE)

Set the high gate value to correspond to the highest expected pulse period (lowest pulse rate). For instance if the meter must display a rate when there is 1 pulse coming into the meter every 10 seconds, set the high gate to 11 seconds. When the signal is removed from the meter, the display will show the last reading for 11 seconds; then it will read zero.

Contact Debounce Filter (FILTER)

The filter function (*FILTER*) can be used for applications where the meter is set up to count pulses generated by switch contacts. There are three settings, *H1* (high speed), *mEd* (medium speed), and *L0* (low speed). High speed disables the contact debounce filter and allows any pulse of the minimum specified width for the selected input type. Press *ENTER* when *mEd* or *L0* is displayed to enable the filter function.

The medium filter ignored signals faster than 250 Hz max, or pulse widths less than 2 ms at 50% duty cycle. The low filter ignores signals higher than 100 Hz, or pulse widths less than 5 ms at 50% duty cycle.

Low-Flow Cutoff (CUTOFF)

The low-flow cutoff feature allows the meter to be programmed so that the often-unsteady output from a transmitter at low flow rates, always displays zero on the meter.

The cutoff value may be programmed from 0.1 to 99,999. Below the cutoff value, the meter will display zero. Programming the cutoff value to zero disables the cutoff feature.

Scaling & Calibration (SCALE CAL)

It is **very important** to read the following information, before proceeding to program the meter:

- There is **no need to recalibrate** the meter for frequency in Hz when first received from the factory.
- The meter is **factory calibrated** for Hz prior to shipment. The calibration equipment is traceable to NIST standards.

IMPORTANT

- Performing a scaling or calibration operation will override any K-Factor programming. Similarly, completing the K-Factor menu will override any scaling or calibration performed on the meter. Verify the method of programming required, use the password protection feature to secure the meter if necessary.

There are three methods of programming the display to show the correct engineering units based on input pulses.

1. Use the *Factor* menu to enter a K-Factor.
2. Use the *Scale* menu to enter the scaling without a signal source.
3. Use the *Calibrate* menu to apply a signal from a calibrator or a flowmeter.

The K-Factor, scale, and calibrate functions are exclusive of each other. The meter uses the last function programmed. The *Scale and Calibrate* functions can use up to 32 points (default is 2). The number of points should be set in *Scale and Calibrate* accordingly under the *Number of Points (noPTS)* menu selection prior to scaling and calibration of the meter, see page 37 for details.

This menu is used to scale and calibrate the meter. For information on using a K-Factor for programming the input, refer to *Entering the K-Factor (FRcEr)* on page 24.

Undoing K-Factor, Scale, and Calibration (Undo?)

Whenever the input programming is being changed from using K-Factor to scaling or calibration; or from scaling or calibration to K-Factor, a confirmation menu appears. This prevents accidental changing of the input programming.

The example below shows a meter programmed with a K-Factor being reprogrammed to utilize input scaling.

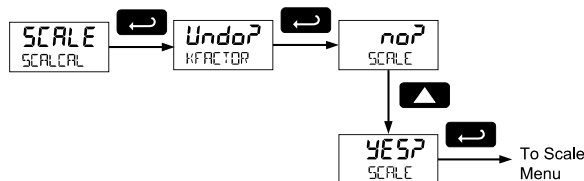

Scaling the Meter (SCALE)

The pulse input can be scaled to display the process variable in engineering units. A signal source is not needed to scale the meter; simply program the inputs and corresponding display values.

A programmed scaled input will work with *Automatic Unit Conversions* as described on page 27. The units for the display values that must be entered are a combination of the programmed *Rate Unit* and the time unit (t RE UNIT) entered in the *Scale* menu.

For example, if the *Rate Unit* is gallons, and the time unit (t RE UNIT) is seconds, the units for the display values entered in the *Scale* menu are gallons/second.

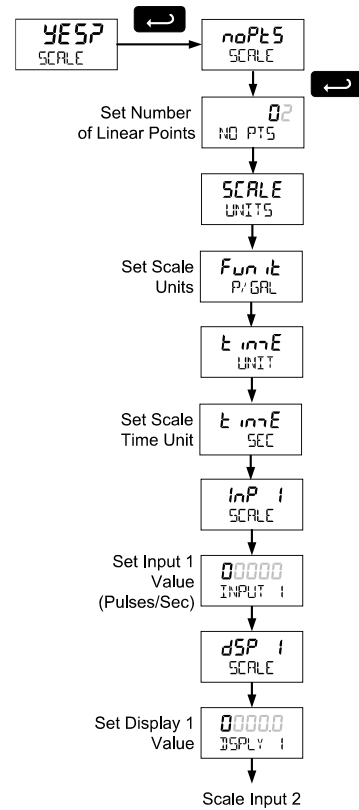

For instructions on how to program numeric values see *Setting Numeric Values*, page 20.

Multi-Point Linearization (noPt5)

Up to 32 linearization points can be selected under the noPt5 function. The multi-point linearization can be used to linearize the display for non-linear inputs.

Number of Points (noPt5)

Enter number of linearization points. The default value is 2 points. For linear inputs requiring only 2 scale points, the number of points can be left at 2.

Scale Units (SCALE UNITS)

Enter the units associated with the desired scale values. Selecting the scale display units allows the meter to perform automatic unit conversions.

Pulse Input Time Unit (TIME UNIT)

This is the time component for the engineering units of the display values being entered. Enter the appropriate units/second, units/minute, units/hour, or units/day that corresponds to the values being entered at the display 1-32 (d5P) menus.

For example, if the display values are being entered in gallons/second the time unit would be set to seconds.

Scale Input and Display (INPUT, DISPLAY)

Each scale input point is defined by an input frequency and a corresponding display value.

The frequency inputs may be entered with up to three decimal places. To access the decimal location digits when entering a frequency, use the **Right** button to scroll to the three decimal location digits.



Manual Multi-point Entry (InP, d5P)

Manual entry of the linearization data is done once the number of points has been selected (noPt5). Input signal levels (InP 1-32) for up to 32 points, along with the desired/corresponding meter reading (d5P 1-32), should be entered for each linearization point.

Each scale point (1-32) has an input value and a display value. The input value is the number of pulses/sec (frequency), and the display value is the corresponding display value for that input in the time unit selected (example: gallons per minute, or GFL/M)

IMPORTANT

- **Save (SAVEP)** After entering the last display value, the calibration entries must be saved (SAVEP) before they will be put into effect. However, you may move past this selection using the Up arrow key if you need to go back and correct and earlier entry. Once confident in the entries however, the user must navigate back to the Save menu screen (SAVEP) and press the Enter key to save the changes.

Calibrating the Meter (CAL)

To scale the meter without a signal source refer to *Entering the K-Factor (FRCTR)* on page 24 or *Scaling the Meter (SCALE)* on page 36.

The pulse input can be calibrated to display the process in engineering units by applying the appropriate input signal and following the calibration procedure.

The use of a calibrated signal source is strongly recommended.

A calibrated input will work with *Automatic Unit Conversions* as described on page 27. The units for the display values that must be entered are a combination of the programmed *Rate Unit* and the time unit (TIME UNIT) entered in the *Calibrate* menu. For example, if the *Rate Unit* is gallons, and the time unit (TIME UNIT) is seconds, the units for the display values entered in the *Calibrate* menu are gallons / second.

The multi-point linearization feature (NOPTS) can be used to linearize the display for non-linear signals. For instructions on how to utilize this feature, see *Multi-Point Linearization (NOPTS)*, page 37.

For instructions on how to program numeric values see *Setting Numeric Values*, page 20.

1. Press the **Up** arrow button to scroll to the *Calibration* menu (CAL) and press **Enter**.
2. The meter displays NOPTS. For a linear signal, press **Up** arrow. For a non-linear signal, refer to *Multi-Point Linearization (NOPTS)*, page 37.
3. The meter displays CAL UNITS. Press **Enter** to select the input units/pulse. The menu will read Fun It.
4. Use the **Up** arrow to select the time unit. If entering display values in units/second, press **Enter**. Otherwise, select the time unit. Refer to *Pulse Input Time Unit (TIME UNIT)* on page 37.
5. The meter displays InP 1. Apply a known signal and press **Enter**. The display will flash while accepting the signal.
6. After the signal is accepted, the meter displays dSP 1. Press **Enter**. Enter a corresponding display value for the signal input, and press **Enter** to accept.
7. The meter displays InP 2. Apply a known signal and press **Enter**. The display will flash while accepting the signal.
8. After the signal is accepted, the meter displays dSP 2. Press **Enter**. Enter a corresponding display value for the signal input and press **Enter** to accept.
9. After completing calibration the SAVEP display will need to be acknowledged using the **Enter** key before calibration will take effect.

IMPORTANT

- **Save (SAVEP)** After entering the last display value, the calibration entries must be saved (SAVEP) before they will be put into effect. However, you may move past this selection using the Up arrow key if you need to go back and correct an earlier entry. Once confident in the entries however, the user must navigate back to the Save menu screen (SAVEP) and press the Enter key to save the changes.

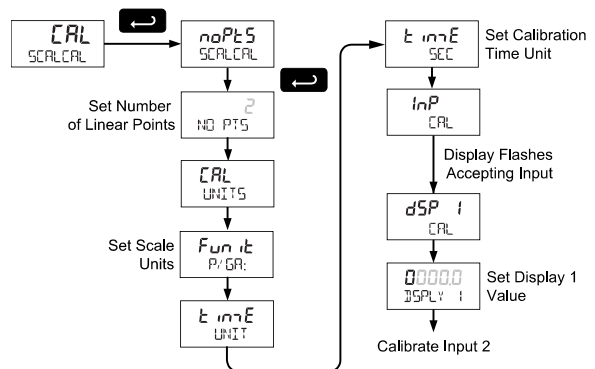

Error Message (Error)

An error message indicates that the calibration or scaling process was not successful. After the error message is displayed, the meter reverts to input 2 during calibration or scaling, allowing the appropriate input signal to be applied or programmed.

The error message might be caused by any of the following conditions:

1. Input signal is not connected to the proper terminals or it is connected backwards.
2. Minimum input span requirements not maintained.
3. Input 1 signal inadvertently applied to calibrate input 2.

Minimum Input Span

The minimum allowed input span is 1 Hz, which is the minimum difference between input 1 and input 2 signals required to complete the calibration or scaling of the meter.

Multi-Point Linearization (n0Pt5)

Up to 32 linearization points can be selected under the n0Pt5 function. The multi-point linearization can be used to linearize the display for non-linear inputs. Linearization data can be entered using a known accurate signal source (InP 1-32) and then entering the desired/corresponding meter reading (dSP 1-32) for that input signal level. These points are established via direct entry (SCALE) or with an external calibration signal (CAL).

Calibration Units (CAL UNITS)

Enter the units associated with the desired scale values. Selecting the units allows the meter to perform automatic unit conversions.

Pulse Input Time Unit (t nE UNIT)

This is the time component to be used when calibrating a number of input pulses per time unit to equal a certain display value.

For example, if the inputs being entered in pulses/second the time unit would be set to seconds.

Total Reset (T RESEt)

This menu is used to select the ways the total and grand total may be reset.

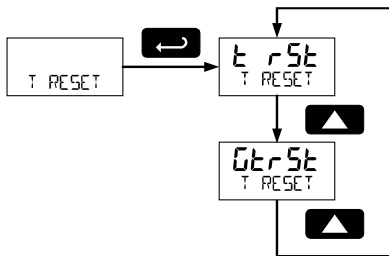

Manual or Automatic Total Reset Function (t rSt)

For manual reset, select T RESEt → t rSt → EnAbL and then select whether manual reset will be enabled (EnAbL) or disabled (dSAbL) using the Up arrow key. Press the Enter button to accept. Disabling reset will avoid inadvertent resets of the total via the front reset button or external reset contact.

For automatic reset, select T RESEt → t rSt → Auto → T DELAY and enter reset delay time in seconds.

The automatic total reset works together with an open collector alarm assigned to trigger on a total set point. Once the output alarm total set point is reached, the meter waits for a programmed amount of time (T DELAY) and then resets the total to zero.

This feature can be used for automatic batch control applications.

Time of Day Total Reset

For timed reset, select T RESEt → t rSt → t nE → T RESEt and enter the time of day at which the total should be reset. The total value will be reset every day at the specified time.

Press the Enter button, at any time, to accept a setting; otherwise press the Menu button to exit without saving changes.

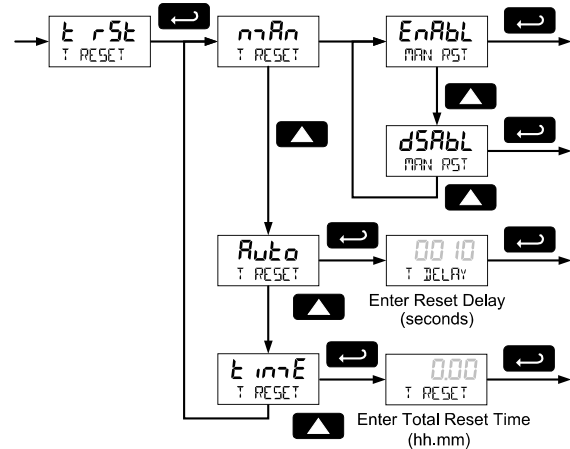

Automatic Total Reset & Total Alarm

The T DELAY parameter is used by the NPN open collector outputs when they are programmed as total alarms. If total reset (t rSt) is programmed to Auto the time delay (T DELAY) is the length of the associated Out 1 or Out 2 total alarm prior to the total being reset to 0.

For information on programming the NPN open collector pulse outputs as total alarms, see Alarm Output (ALr) programming on page 34.

Manual or Automatic Grand Total Reset Function (GTrSt)

For manual reset, select T RESET → GTrSt → rAn and then select whether manual reset will be enabled (EnAbL) or disabled (dSAbL) using the Up arrow key. Press the Enter button to accept. Disabling reset will avoid inadvertent resets of the total via the front reset button.

For automatic reset, select T RESET → GTrSt → RuLo → T DELAY and enter reset delay time in seconds.

The automatic grand total reset works together with an open collector alarm assigned to trigger on a grand total set point.

Once the grand alarm output grand total set point is reached, the meter waits for a programmed amount of time (T DELAY) and then resets the grand total to zero.

Time of Day Grand Total Reset

For timed reset, select T RESET → t rSt → t rE → T RESET and enter the time of day at which the total should be reset. The total value will be reset every day at the specified time.

Press the Enter button, at any time, to accept a setting; otherwise press the Menu button to exit without saving changes.

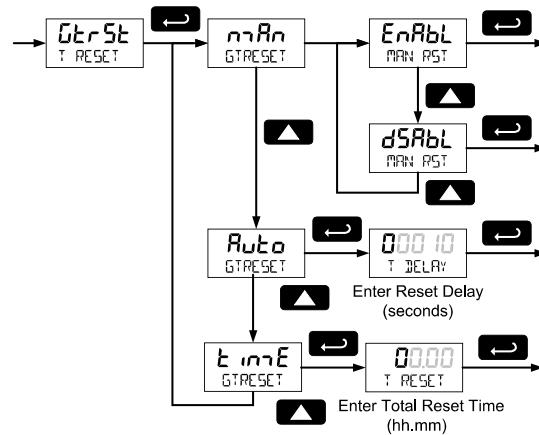

Grand Total Automatic Reset & Grand Total Alarm

The T DELAY parameter is used by the NPN open collector outputs when they are programmed as grand total alarms. If grand total reset (GTrSt) is programmed to RuLo, the time delay (T DELAY) is the length of the associated Out 1 or Out 2 grand total alarm prior to the grand total being reset to 0.

For information on programming the NPN open collector pulse outputs as grand total alarms, see Alarm Output (ALr) programming on page 34.

Press the Enter button, at any time, to accept a setting; otherwise press the Menu button to exit without saving changes.

Setting Up Passwords (PASSWORD)

The *Password* menu is used to program a five-digit password to prevent unauthorized changes to the programmed parameter settings, to restrict the ability to reset the total and grand total, and to permanently lockout the ability to reset the grand total and any grand total related parameters.

The lock symbol is displayed to indicate that settings are password protected.

Record all passwords for future reference. If appropriate, it may be recorded in the space provided.

Model:	
Serial Number:	
Setting Lockout Password (PASS):	— — — — —
Total Reset Password (PASS T):	— — — — —
Grand Total Reset Password (PASS GT):	— — — — —

Locking Meter Setup Parameters

Enter the *Password* menu, select *PASS*, and program a five-digit password. The meter will return to *Run Mode* after locking any of the passwords.

For instructions programming numeric values see *Setting Numeric Values*, page 20.

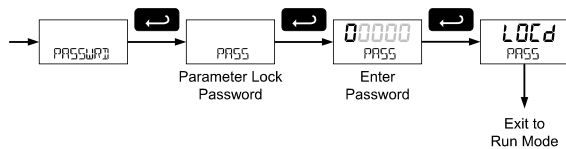

Making Changes to a Password Protected Meter

If the meter is password protected, the meter will display the message *PASS LOCKED* when an attempt is made to enter the *Setup* menu or *Advanced* menu.

Press the **Enter** button while the message is being displayed and input the correct password followed by the **Enter** button to gain access to the menu. After exiting the programming mode, the meter returns to its password protected condition.

Password Restricting Total & Grand Total Reset

To restrict resetting of the total, enter the *Password* menu, select *PASS T*, and program a five-digit password. This will deactivate the remote reset connections. Total will only be able to be reset through the *SafeTouch* Buttons or mechanical pushbuttons if the appropriate password is entered.

To restrict resetting of the grand total, enter the *Password* menu, select *PASS GT*, and program a five-digit password.

Resetting Total & Grand Total on a Password Protected Meter

If the meter is password protected for total or grand total reset, the meter will display the message *PASS T* or *PASS GT* when an attempt is made to enter the password protected total or grand total *Reset* menus. Input the password and press the **Enter** button to reset the total or grand total.

The password requirement may be disabled by entering the password in the *Password* menu for total (*PASS T*) or grand total (*PASS GT*).

Disabling Password Protection

To disable the password protection, access the *Password* menu, select the type of password to be disabled, and enter the correct password as shown below. That password is now disabled (set to 00000) until a new password is entered.

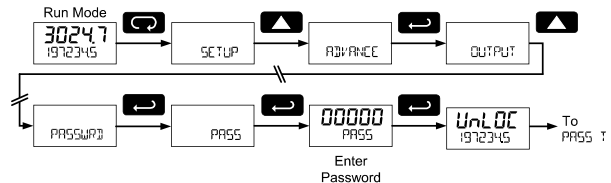

If the correct five-digit password is entered, the meter displays the message *UnLOC (unlocked)* and the protection is disabled until a new password is programmed.

If the password entered is incorrect, the meter displays the message *PASS LOCKED*, allowing the user to try again. If **Enter** is not pressed within 3 seconds, the meter returns to *Run Mode*.

Did you forget the passwords?
 The password may be disabled by entering a master password. If you are authorized to make changes, enter the master settings lockout (*PASS*) password 50865, the master total reset (*PASS T*) password 80034, or the master grand total reset (*PASS GT*) password 80034 to unlock the meter.

Non-Resettable Grand Total

The grand total may be configured to be a non-resettable grand total. This is a permanent setting. Configuring the grand total as a non-resettable grand total locks out all setup parameters that could be used to reset the grand total or change the setup of the grand total, including input selection, rate scaling, and conversion factors.

To configure the meter for non-resettable grand total mode, enter the non-resettable grand total password listed below, into the *Pass GT* parameter in the *Password* menu.

The non-resettable grand total permanently locks the following setup menus and parameters from being changed: input selection, K-Factor, K-Factor units, grand total units, grand total conversion factor, grand total decimal point, scaling, calibration, grand total alarms, pulse input filter, and cutoff.

CAUTION

- Locking the meter into a non-resettable grand total is not reversible. It is a permanent meter configuration. Doing so will permanently prevent most input parameters from being altered. This should be the last step after verifying all setup parameters.

Non-resettable grand total password: 50873

Non-Resettable Grand Total Locked Menus & Parameters		
Display	Parameter/Menu	Action/Setting Locked
INPUT	Input	All Input type selection menu parameters
UNIT	Grand total units	Set grand total units
CONF	Grand total conversion factor	Enter the Grand Total Conversion Factor menu
GRAND TOTAL DECIMAL	Grand total decimal point	Enter the grand total display decimal point
FACTOR	K-Factor	All K-Factor menu parameters
SCALE	Scale	All Scale menu parameters
CAL	Calibrate	All Calibrate menu parameters
RESET	Grand total reset	All the Grand Total Reset menu parameters
PASS GT	Password grand total	Enter the grand total reset password
GRAND TOTAL ALARM	Grand total alarm	All grand total alarm output menu parameters
FILTER	Filter	Enter Filter parameter
CUTOFF	Low-flow cutoff	Enter Low-Flow Cutoff parameter

The above menus remain accessible; however the parameters listed above within the menus are locked and may not be changed.

Custom Menu (CUSTOM)

The *Custom* menu is used to modify the initial programming menus that appear in the Main Menu when the **Menu** button is pressed in Run Mode.

CAUTION

- Changing the default menu setup with the *Custom* menu feature may change the setup and operation procedures described in this manual. Only operators familiar with the programming and operation of this unit should use this feature.

Eight menu positions are available. Menu positions 6 and 7 are factory programmed for *Setup* and *Advanced*.

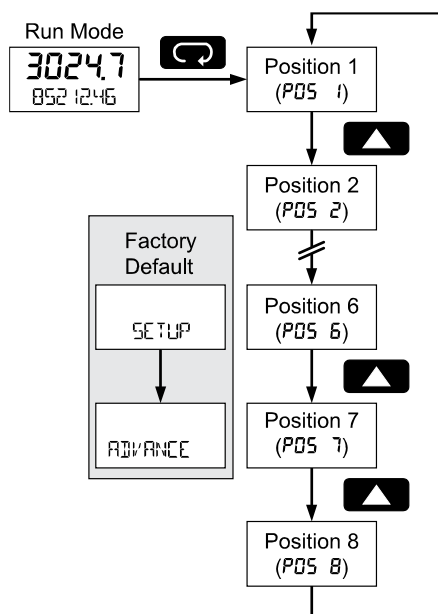

To add a menu or parameter to the menu structure, or change the default menus, press **Enter** at the desired menu in the position (POS) to be edited and use the **Up** or **Right** arrows to select the desired menu item for that position. See the following table for a complete list of the available menu selections for each position.

Custom Menu Parameters		
Display	Parameter/Menu	Action
NONE	None	Set no menu position display
INPUT	Input	Set to show <i>Input</i> menu
KFACTOR	K-Factor	Set to show <i>K-Factor</i> menu
UNITS	Units	Select standard units or custom unit/tag
DECIMAL	Decimal	Set to show <i>Decimal</i> menu
DISPLAY	Display	Set to show <i>Display</i> menu
A OUT	Analog out	Set to show <i>Analog Output</i> menu
RATE.DP	Rate decimal Point	Set to show <i>Rate Decimal Point</i> menu
TOTAL.DP	Total decimal point	Set to show <i>Total Decimal Point</i> menu
GRTOT.DP	Grand total decimal point	Set to show <i>Grand Total Decimal Point</i> menu
SCALE	Scale	Set to show <i>Scale</i> menu
CAL	Calibrate	Set to show <i>Calibrate</i> menu
T BASE	Time base	Set to show <i>Time Base</i> menu
T FACTR	Total conversion factor	Set to show <i>Total Conversion Factor</i> menu
T RESET	Total reset	Set to show <i>Total Reset</i> menu
GTFACTR	Grand total conversion factor	Set to show <i>Grand Total Conversion Factor</i> menu
GTRESET	Grand total reset	Set to show <i>Grand Total Reset</i> menu
PASS	Password	Program password to lock meter parameters
PASS T	Total password	Program password to prevent total reset
PASS GT	Grand total password	Program password to prevent grand total reset. May permanently lock out grand total related parameters and reset
OUTPUT	Output	Set to show <i>Output</i> menu
OUT 1	Out 1	Assign function of pulse output 1
OUT 2	Out 2	Assign function of pulse output 2
DATALOG	Data Log	Enter <i>Data Log</i> menu
LOGTIME	Log Time	Set daily data log times
INTERVL	Interval	Set interval log times
LOGVIEW	Log View	Enter <i>Log View</i> menu
PASSWORD	Password	Set to show <i>Password</i> menu
SETUP	Setup	Set to show <i>Setup</i> menu
ADVANCE	Advance	Set to show <i>Advanced</i> menu
SYSTEM	System	Set to show <i>System</i> menu

System (SYSTEM)

The system function is used to set the real time clock, set the data logger times, enable/disable the backlight, access analog output controls used in troubleshooting, store, restore, and backup restore feature, enable / disable the battery power alert symbol on the display, and review basic system information.

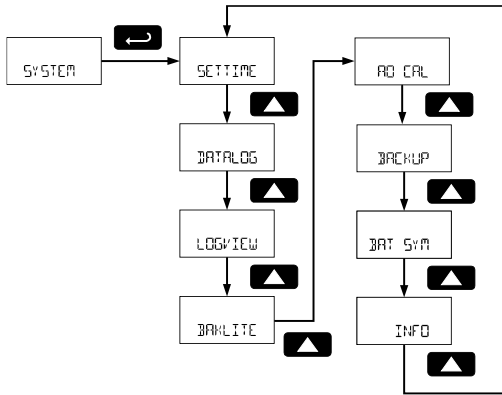

Set Real Time Clock (SETTIME)

The real time clock is used to trigger data log events and is recorded at every logged data point. The menu displays the date and time.



Figure 18. Date Display Example

The above display example shows the date to be June 27, at 14 hours, 32 minutes, and 36 seconds. The display date will toggle with the year.

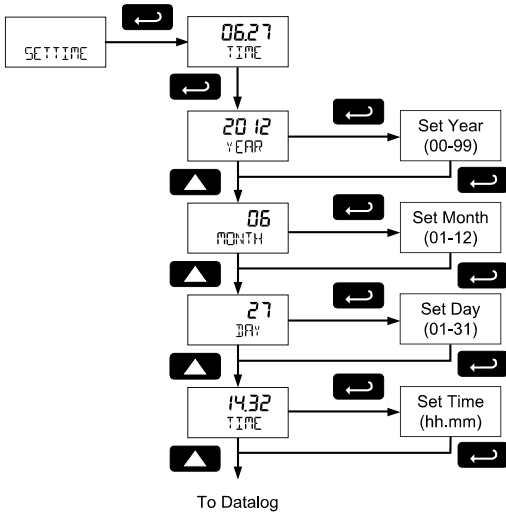

The year, month, day, hour, and minute may all be set by the user. The real time clock will need to be reset if external power and battery power are lost.

Changing the time (hours and minutes) will reset the seconds clock to 0.

Data Log Setup (DATALOG)

The Data Log menu is used to setup and enable the data log functions. The meter may contain up to 1024 records, each containing date, time, rate, total, grand total, and log number.

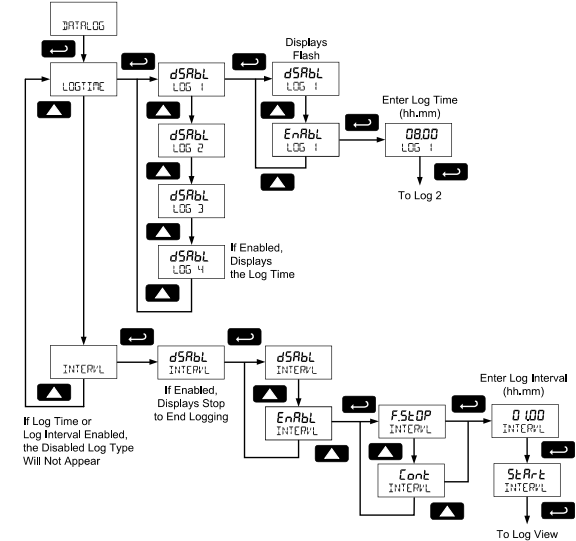

There are two ways to configure the time when a data log is recorded. The *Log Time* feature allows up to 4 data logs to be recorded each day, at specific times. The *Log Interval* feature allows a data log to be recorded each time a time interval has passed. Only the *Log Time* or *Log Interval* may be active at once. While one type of data logging has been enabled, the other menu will be inaccessible.

Log Time Setup (LOGTIME)

The *Log Time* menu contains four log points (LOG 1 to LOG 4). Each log time is configured separately. For each daily log time desired, enable a log, and set the log time for the hours and minutes the log is to be recorded. The time is set in real-time, based on the real time clock setup.

The *Log Time* feature will roll-over, deleting the oldest data logs (in blocks of 8) when the log is full and new logs must be recorded. This makes it the most useful for long-term data logging.

Interval Setup (INTERVL)

The *Interval* menu sets the time interval for data logging. Every time interval, one data point will be recorded. To enable interval data logging, enable the feature, and set the interval time for the hours and minutes between each log.

If set to *F5tOP*, the *Log Interval* feature will not delete old data, and data logging will stop when the log is full. This makes it the most useful for short periods and logging specific functions.

If set to *Cont*, the *Log Interval* feature will delete the old data when full and continue logging data. The *Log Interval* feature will roll-over, deleting the oldest data logs (in blocks of 8) when the log is full and new logs must be recorded. This makes it the most useful for long-term data logging.

View Data Log (LOGVIEW)

The *Log View* menu allows on-screen browsing of the data log points stored in the meter. Data points may be navigated by viewing the log number, date and time, total, or grand total amounts. A known log may be jumped to immediately, avoiding a lengthy search for data. All logs may be deleted with the **ERASE** command, requiring confirmation.

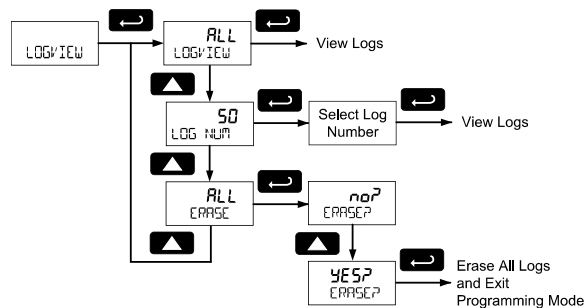

Once the log records are displayed, use the **Up** and **Right** arrows to change the log entry being viewed. The **Enter** key changes the displayed information for the same log.

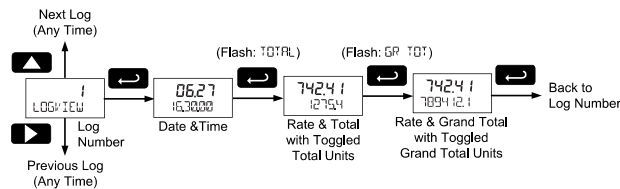

Backlight (BACKLITE)

The *Backlight* menu is used to enable or disable the backlight. This feature is particularly important for the battery-powered models with momentary backlight. This feature is not available for models with a loop output powered backlight.

Analog Output Calibration (AO CAL)

This feature is only used at the factory for calibration of the 4-20 mA analog output, if the meter has this option. It is not recommended to access this menu without instruction from technical support.

Backup & Restore (BACKUP)

The meter saves all parameter settings, and no reprogramming is necessary when power is lost and restored to the meter. The total and grand totals are saved during a power loss. Only the maximum and minimum displays are reset when power is lost

The features are used to save and restore programmed settings. Programming can be restored to a known saved good configuration, or to factory defaults. This is useful to restore meters whose programming has been altered in unknown ways, or to quickly restore known good settings if mistakes are made during reprogramming.

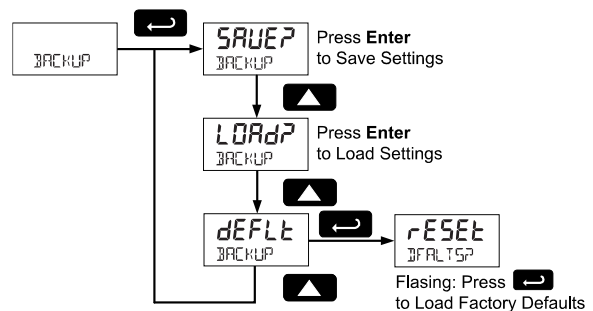

The save feature (**SAVE?**) saves all current parameter settings into the memory of the backup restore. The backup restore feature is loaded with factory default settings until a new configuration is saved.

The *Load Backup* feature (**LOAD?**) restores all parameters to the programmed values stored in backup restore memory. The *Load Backup* feature will not affect the current password settings or allow the editing of permanently locked parameters due to the enabling of the non-resettable grand total feature. See *Non-Resettable Grand Total* described on page 42.

The *Reset Defaults* feature (**dEFLt?**) restores all parameters to the factory default values. Factory default reset does not change the saved backup restore settings, override passwords, or edit parameters locked by a permanent non-resettable grand total. See *Non-Resettable Grand Total*, as described on page 42.

CAUTION

- Once meter parameters have been saved to memory by the backup restore feature there is no recovering of the previously saved settings.
- Once parameters have been loaded into the meter from the backup restore feature there is no recovering of the previously programmed settings.

Battery Power Symbol Alert (BAT SYM)

The *Battery Power Symbol Alert* menu is used to enable or disable the battery alert symbol on the display. This is a useful way to be aware of a power failure to a model with battery backup.

When enabled, the battery symbol will appear whenever the meter is powered as a battery backup. This is detected when the meter being powered from DC or loop-power experiences power loss, subsequently switching over to battery power.

The indicator will not appear if the meter is powered on via battery power, only when there is applied power to the DC or loop-power lines, followed by power loss. This prevents the battery indicator from appearing at all times for a primarily battery powered application.

The battery symbol will flash in a low battery condition regardless of the setting of this parameter.

Information (INFO)

The *Information* menu is part of the *System* features menu. It shows software identification number, version number, and extended model number. To view this information:

Go to the *Information* menu (INFO) and press **Enter** button.

Continue pressing **Enter** to scroll through the displays.

Following the information display, the meter will exit the *Advanced* features menu and return to Run Mode.

Serial Communications (COMM)

The *Communications* menu is used to setup serial communications parameters necessary for communication via Modbus.

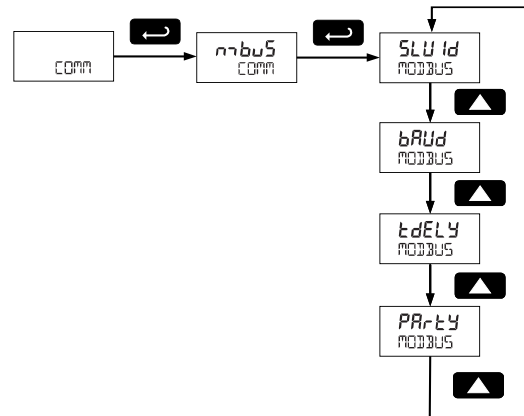

The Modbus communications uses a 2-wire plus ground RS-485 connection with the Modbus RTU option.

When using more than one meter in a multi-drop mode, each meter must be provided with its own unique address. The meter address (Slave ID) may be programmed between 1 and 247. The baud rate may be set to 1,200; 2,400; 4,800; 9,600; 19,200; 38,400; 57,600; or 115,200 bps. The transmit delay may be set between 0 and 199 ms. The parity can be set to even, odd, or none with 1 or 2 stop bits.

Refer to the ProtEX Modbus Register Tables located at www.prediq.com for details.

Standby Mode (STANDBY)

Standby mode is available on battery powered and battery backup models only.

The *Standby* menu is used to enter a power-saving standby mode that will turn off the display and activate a low power mode for the through-glass buttons. Signal processing operations will continue to run. This mode may be used to reduce power consumption and increase battery life when the meter is not in use.

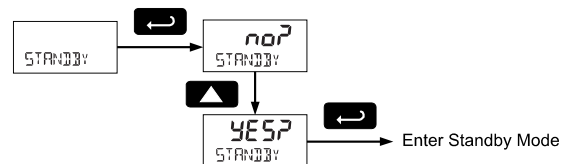

It may take up to 3 seconds for the meter to enter standby mode after confirming the flashing display with the **Enter** button.





Wakeup the Meter (WAKEUP)

To bring the meter out of standby mode, press any button and Wakeup (WAKEUP) will flash. If using SafeTouch buttons, it may be required to hold the button for several seconds.

Confirm that the meter should awaken to Run Mode by pressing the **Enter** key while WAKEUP is flashing. The meter will return to the normal Run Mode.

Operation

Front Panel Buttons Operation

Symbol	Description
	<ul style="list-style-type: none"> Hold the Menu SafeTouch button when in power save mode (display will show ) to awaken SafeTouch buttons. Press the Menu button to enter Programming Mode. Press the Menu button during Programming Mode to return to the previous menu selections. Hold the Menu button for 1.5 seconds at any time to exit Programming Mode and return to Run Mode. Press and hold the Menu button for 3 seconds to access the <i>Advanced Features</i> of the meter.
	<ul style="list-style-type: none"> Press the Right arrow button to move to the next digit or decimal position during programming. Press Right to go forward through most selection menus. Press Reset to reset the total, or values displayed in the bottom display (grand total, max, or min). Press Enter after Reset to confirm the reset.
	<ul style="list-style-type: none"> Press Display when in Run Mode to display the grand total, again to display the maximum, and again to display the minimum reading since last reset. These displays will time out in 12 seconds, or press Display until total is displayed in the lower display. Press Enter to lock this display, and disable the 12 second time out. Press the Up arrow button to scroll forward through the menus, decimal point, or to increment the value of a digit.
	<ul style="list-style-type: none"> Press the Enter button to access a menu or to accept a setting. Press Enter to lock display of grand total, Max or Min readings (disables 10 second timeout). Press Enter while the grand total, max, or min reading is locked on the lower display to return to run mode. Press Enter to acknowledge alarm (if enabled).

The following SafeTouch button information is reprinted from *SafeTouch Button Operation* on page 18.

SafeTouch Button Operation

To actuate a button, press and remove one finger to the glass directly over the marked button area. Remove finger to at least 4 inches away from the window in between button activations. SafeTouch and mechanical buttons may be held to cycle through menus or digits in place of repeatedly pushing a button.

 **SafeTouch Power Save Mode**

SafeTouch buttons enter a power saving mode after three minutes of inactivity. This mode is indicated by the SafeTouch power symbol () appearing in the lower right of the display. Only the **MENU** button is monitored in this mode. To activate the SafeTouch buttons, press and hold the menu button for up to five seconds. The display will read **POWER**, and the SafeTouch buttons will be fully enabled.

SafeTouch Disabled Mode

When the cover is removed, the four mechanical buttons located next to the sensors may be used. The sensors are disabled when a mechanical button is pressed and will automatically be re-enabled after 60 seconds of inactivity. The SafeTouch power symbol () will blink in the lower right of the display if the buttons are disabled due to a mechanical pushbutton being pressed.

 **IMPORTANT**

- SafeTouch will not work if two or more buttons are detected as being pressed simultaneously. Be careful to avoid triggering multiple buttons or reaching across one button location to press another.

SafeTouch Button Tips and Troubleshooting

The SafeTouch Buttons are designed to filter normal levels of ambient interference and to protect against false triggering, however it is recommended that the SafeTouch Buttons be turned off (slide THRU-GLASS BUTTONS switch located on the back of the display module to OFF) if there is an infrared interference source in line-of-sight to the display or if the buttons are not needed.

SafeTouch Button Tips:

- To the extent possible, install the display facing away from sunlight, windows, reflective objects and any sources of infrared interference.
- Keep the glass window clean.
- Tighten the cover securely.
- Use a password to prevent tampering.
- If the cover has not been installed and secured tightly, it may take a moment for the SafeTouch buttons to properly self-calibrate when the cover is tightened.

After all connections have been completed and verified, connect the ribbon cable to the display module, fasten the display module to the base, install enclosure cover, and then apply power.

SafeTouch Button Equalize Delay

The SafeTouch buttons are designed to constantly recalibrate for ambient conditions. When the cover position is changed, the cover is removed, or an object is removed that was placed over the front window, it may take a moment for the SafeTouch buttons to recalibrate to the change in conditions.

Allow up to 2 minutes for the SafeTouch buttons to recalibrate to new conditions in these cases where the cover position was changed, or the front window is being unblocked.

Grand Total Reading (Gr TOTAL)

The grand total is a separate total that is not reset when the total is reset. This allows the complete total to be tracked by the grand total, while individual batch, or daily totals are reset regularly.

To display the grand total, press the **Up/Display** button. The display will read **Gr TOTAL**, and the **GT** symbol will appear indicating the grand total is being displayed on the bottom display. After 10 seconds, the bottom display will return to showing total. To lock the grand total on the display, press **Enter**. Pressing **Menu** at any time will return to normal Run Mode.

Note: If the Display menu has been setup to display the grand total on the bottom display, pressing the **Up/Display** button will display the maximum and minimum readings followed by the total.

Previous Total & Grand Total

The previous total and grand total values, prior to being reset, are stored in memory. These values can be viewed using the Up/Display button.

Display Max, Min & Previous Totals

The maximum and minimum (peak & valley) readings reached by the rate are stored in the meter since the last reset or power-up. The meter shows **MAXIMUM** or **MINIMUM** to differentiate between Run Mode and max/min display.

To display the maximum and minimum readings and the previous total and grand total use **Up/Display** button to cycle the bottom display. Maximum and minimum are displayed after the grand total.

Press the **Enter** button to remain in Max / Min / Previous display mode. If **Enter** is not pressed, the Max / Min / Previous display readings will time out after ten seconds. The meter will return to display the actual reading. Pressing **Menu** at any time will return to normal Run Mode.

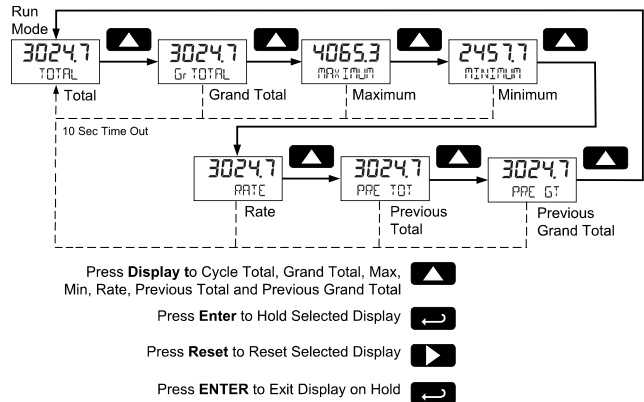

Resetting the Total (rESEt TOTAL)

If manual *Total Reset* is enabled in the *Advanced* menu, the total may be reset by pressing the **Reset** button and using the **Enter** button to confirm the reset.

Additionally if programmed for manual reset, the total may be reset using a normally open pushbutton connected across the terminals RST and COM.

Note: *The total is cleared immediately when Enter button is pressed. Totalization will then continue, even if the Enter button or external reset button continues to be held down/triggered.*

Resetting the Grand Total (rESEt Gr TOT)

If manual *Grand Total Reset* is enabled in the *Advanced* menu, the grand total may be reset using the **Reset** button.

To reset the grand total, display the grand total by pressing the **Up/Display** button. While grand total is being displayed, press the **Reset** button. Confirm the reset with the **Enter** button.

Resetting Max/Min Readings (RESET MAXIMUM, MINIMUM)



The maximum and minimum readings may be reset by pressing the **Reset** button while displaying either the maximum or minimum. The display will show **RESET** to verify the reset of maximum or minimum value.

The maximum and minimum must be reset individually.





Troubleshooting

Certain sequences of events can cause unexpected results. To solve these issues, it is best to start fresh from factory defaults and use the manual as a step by step programming guide, rather than a random approach to programming. See *Reset Meter to Factory Defaults* on page 50 for details on resetting the meter to factory defaults. In addition, for best results, we recommend using the free MeterView EX software for all programming needs.

Troubleshooting Tips

Symptom	Check/Action
No display or faint display	Check power connection. Press and hold Menu key for 5 seconds to check for Standby mode. If "WAKEUP" is displayed, press the Enter key to awaken the meter from Standby mode.
SafeTouch Buttons do not respond	If  is displayed, hold Menu SafeTouch button to leave power save mode. If  is flashing, wait 60 seconds to leave mechanical pushbutton lockout mode. If the cover was recently tightly secured, you may need to wait up to 2 minutes for buttons to self-calibrate to the new cover position due to glass reflection. Verify the THRU-GLASS BUTTONS switch located on the back of the display module is in ON position. Sunlight can interfere with the sensors. It is recommended to shield the window while operating the buttons by standing so as to block direct sunlight.
Rate display unsteady	Increase low gate setting in <i>Advanced</i> menu.
Meter displays error message during calibration (ERROR SPAN)	Verify minimum input span requirements
Meter flashes 99999	Check input signal is within scaled range of 99999.
Display stuck displaying MAXIMUM or MINIMUM	Press Enter (Unlock) to exit Max/Min display
Display response is too slow	Check if gate settings can be lowered
If the display locks up or the meter does not respond	Perform hard reset by removing the display module or by removing external loop or DC power.
Backlight does not appear.	Backlight is intended for viewing assistance in dim lighting. It may not be noticeable under good lighting conditions. Battery powered models turn off the backlight after ten seconds of button inactivity.
Other symptoms	Call Technical Support for assistance.

Quick User Interface Reference

Pushbutton	Function
	Go to Programming mode, back out one level of programming. Hold to enter Advanced Features mode. Leave grand total/max/min mode.
	Move to next digit or decimal point position. Go to <i>reset</i> menu. Return to last programming menu.
	Move to next selection or increment digit. Enter Grand Total/Max/Min display mode.
	Accept selection/value and move to next selection. Acknowledge Alarm.

Cycle Rate, Total, Grand Total, Max/Min, Previous Totals on Lower Display

While in Run Mode, pressing **Display** will cycle the rate, total, grand total, max/min, previous total & grand total display.

In this mode, the display will show the rate, total, grand total, maximum, or minimum values since last reset when they are not selected as the top or bottom display. The grand total, max, min, previous total & grand total will display for 10 seconds.

Press **Enter** while displaying the rate, total, grand total, max, min, previous total & grand total to disable the 10 second time-out and continuously display the selected parameter.

Press **Enter** again to disable this display lock.

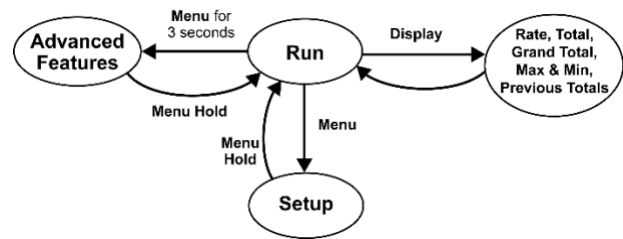

Contact Precision Digital

Technical Support

Call: (800) 610-5239 or (508) 655-7300

Fax: (508) 655-8990

Email: support@predig.com

Sales Support

Call: (800) 343-1001 or (508) 655-7300

Fax: (508) 655-8990

Email: sales@predig.com

Place Orders

Email: orders@predig.com

For the latest version of this manual please visit

www.predig.com

PRECISION DIGITAL CORPORATION

233 South Street • Hopkinton MA 01748 USA
Tel (800) 343-1001 • Fax (508) 655-8990

www.predig.com

