

# ProtEX-MAX PD8-6000 Explosion-Proof Process Meter

## Instruction Manual



IECEX

MeterView Pro

USB Install

- Fully-Approved Explosion-Proof Meter
- 0-20 mA, 4-20 mA, 0-5 V, 1-5 V, and  $\pm 10$  V Field Selectable Inputs with  $\pm 0.03\%$  Accuracy
- Dual-Line 6-Digit Display, 0.6" (15 mm) & 0.46" (12 mm)
- SafeTouch Through-Glass Button Programming
- Display Mountable at 0°, 90°, 180°, & 270°
- Isolated 24 VDC @ 25 mA Transmitter Power Supply
- Easy Field Scaling in Engineering Units without Applying an Input
- 4 Relays with Interlocking Capability + Isolated 4-20 mA Output Option
- Free PC-Based, On-Board, MeterView Pro USB Programming Software
- SunBright Display Standard Feature; Great for Outdoor Applications
- Operating Temperature Range: -40 to 60°C (-40 to 140°F)
- FM Approved as Explosion-Proof / Dust-Ignition-Proof / Flame-Proof
- CSA Certified as Explosion-Proof / Dust-Ignition-Proof / Flame-Proof
- ATEX and IECEx Certified as Flame-Proof
- Input Power Options: 85-265 VAC / 90-265 VDC or 12-24 VDC / 12-24 VAC
- Display Input in Two Different Scales Simultaneously - Great for Level Applications
- Multi-Pump Alternation Control
- Round Horizontal Tank Function; Just Enter Diameter & Length
- 32-Point Linearization, Square Root Extraction and Programmable Exponent Function
- Password Protection
- Programmable Display, Function Keys & Digital Inputs
- Flanges for Wall or Pipe Mounting
- Explosion-Proof, IP68, NEMA 4X Die-Cast Aluminum Enclosure
- On-Board RS-485 Serial Communications
- Modbus® RTU Communication Protocol Standard
- Four 3/4" NPT Threaded Conduit Openings (Two Plugs Installed)
- Pipe Mounting Kits
- Stainless Steel Tag Available
- 3-Year Warranty

## PRECISION DIGITAL CORPORATION

233 South Street • Hopkinton MA 01748 USA  
Tel (800) 343-1001 • Fax (508) 655-8990  
[www.predig.com](http://www.predig.com)

PRECISION  
DIGITAL

# The Complete **ProtEX™** Series

MAX



PD8-154  
**4-Point Alarm  
Annunciator**



PD8-6100  
**Strain Gauge Meter**



PD8-158  
**8-Point Alarm  
Annunciator**



PD8-6200  
**Analog Input  
Flow Rate/Totalizer**



PD8-765  
**Process &  
Temperature Meter**



PD8-6210  
**Analog Input Batch  
Controller**



PD8-6000  
**Process Meter**



PD8-6262  
**Analog Dual-Input  
Flow Rate/Totalizer**



PD8-6001  
**Feet & Inches  
Level Meter**



PD8-6300  
**Pulse Input  
Flow Rate/Totalizer**



PD8-6060  
**Dual-Input  
Process Meter**



PD8-6310  
**Pulse Input  
Batch Controller**



PD8-6080  
**Modbus® Scanner  
with Dual Analog Input**



PD8-6363  
**Pulse Dual-Input  
Flow Rate/Totalizer**



PD8-6081  
**Feet & Inches  
Modbus® Scanner**



PD8-7000  
**Temperature Meter**

Go to [PREDIG.COM](http://PREDIG.COM) for details on the entire ProtEX-MAX Series Meters

**Disclaimer**

The information contained in this document is subject to change without notice. Precision Digital makes no representations or warranties with respect to the contents hereof and specifically disclaims any implied warranties of merchantability or fitness for a particular purpose. See Warranty Information and Terms & Conditions on [www.predig.com](http://www.predig.com) for complete details.

**CAUTION**

- Read complete instructions prior to installation and operation of the meter.

**WARNINGS**

- Risk of electric shock or personal injury.
- This product is not recommended for life support applications or applications where malfunctioning could result in personal injury or property loss. Anyone using this product for such applications does so at his/her own risk. Precision Digital Corporation shall not be held liable for damages resulting from such improper use.
- Failure to follow installation guidelines could result in death or serious injury. Make sure only qualified personnel perform the installation.
- Never remove the meter cover in explosive environments when the circuit is live.
- Cover must be fully engaged to meet explosion-proof/dust-ignition-proof/flame-proof requirements.

**WARNING**

Cancer and Reproductive Harm - [www.P65Warnings.ca.gov](http://www.P65Warnings.ca.gov)

**Limited Warranty**

Precision Digital Corporation warrants this product against defects in material or workmanship for the specified period under "Specifications" from the date of shipment from the factory. Precision Digital's liability under this limited warranty shall not exceed the purchase value, repair, or replacement of the defective unit. See Warranty Information and Terms & Conditions on [www.predig.com](http://www.predig.com) for complete details.

**Registered Trademarks**

All trademarks mentioned in this document are the property of their respective owners.

© 2022 Precision Digital Corporation.  
All rights reserved.

**FREE MeterView Pro Programming Software**

The meter can be powered from the USB connection. When using the USB connection, **DO NOT** apply AC or DC power to the meter.

The easiest and quickest way to program your ProtEX-MAX meter is to use the FREE MeterView Pro programming software. This software is loaded into the meter and connects and installs directly to your PC with a USB cable. We recommend that the first thing you do after taking the meter out of the box is connect the ProtEX-MAX to your PC with the provided USB cable – do not use a different cable. **DO NOT** apply AC or DC power to the meter while your PC is connected to the meter as it will disrupt the USB signal. You don't even have to apply an input signal.

MeterView Pro programming software is intuitive, and most customers can get their meter programmed as they like without even looking in the manual.

Watch MeterView Pro Software Video at  
[www.predig.com/meterviewpro](http://www.predig.com/meterviewpro)

In addition to programming, the software may be used for:

- Monitoring
- Datalogging using your PC
- Generating and saving programming files for later use

Once your meter is programmed the way you want it, you can wire it up for your application per the instructions in this manual and install it. If you find that you need to make adjustments to the programming after the meter is installed, you can use the programming buttons and the instructions in this manual to do so.

**WARNING**

- The meter should only be connected to a computer while it is located in a safe area.

## Table of Contents

Introduction.....	7
Ordering Information.....	7
Key Features.....	9
Specifications .....	17
General.....	17
Process Inputs .....	18
Relays .....	18
USB Connection.....	18
Isolated 4-20 mA Transmitter Output Option.....	19
RS-485 Serial Communications .....	19
Modbus® RTU Serial Communications .....	19
Digital Input (F4).....	19
Digital Inputs & Outputs .....	19
MeterView Pro Software .....	19
Compliance Information.....	20
Electromagnetic Compatibility .....	20
Product Ratings and Approvals .....	20
EU Declaration of Conformity.....	21
Safety Information .....	21
Installation.....	21
Unpacking.....	21
Mounting.....	22
Installation Overview .....	24
MeterView Pro Software .....	24
Transmitter Supply Voltage Selection (P+, P-).....	25
Connections .....	25
Required & Factory Wired Connection.....	25
ProVu Electronics Module Layout.....	26
USB Connection .....	26
Power Connections.....	27
Signal Connections .....	27
Relay Connections.....	27
Switching Inductive Loads.....	28
RS-485 Connections.....	28
RS-485 Multi-Drop Connection .....	28
Digital I/O Connections .....	29
F4 Digital Input Connections .....	29
4-20 mA Output Connections.....	29
Analog Output Power Supply .....	29
Remote Programming.....	30
Interlock Relay Feature .....	30
Setup and Programming.....	31
Overview .....	31
LED Status Indicators.....	31
Programming Buttons .....	32
SafeTouch Buttons .....	32
Display Functions & Messages .....	33
Main Menu .....	34
Setting Numeric Values.....	35
Setting Up the Meter (SEtUP).....	35
Setting the Input Signal (InPUt).....	35
Setting the Display Units or Custom Tags (uNItS) .....	36
Setting the Decimal Point (dEc Pt) .....	36
Programming the Meter (PrOU) .....	37
Setting the Display Parameter & Intensity (dSPLRy) .....	39
Display Intensity (d-IntY).....	39

- Setting the Relay Operation (rELRY)..... 40**
  - Setting the Relay Action..... 40
  - Programming Set and Reset Points ..... 41
  - Setting Fail-Safe Operation..... 41
  - Programming Time Delay ..... 41
  - Relay Action for Loss of 4-20 mA Input (Loop Break) ..... 41
- Relay and Alarm Operation Diagrams..... 41**
  - High Alarm Operation (Set > Reset) ..... 41
  - Low Alarm Operation (Set < Reset) ..... 42
  - High Alarm with Fail-Safe Operation (Set > Reset)..... 42
  - Low Alarm with Fail-Safe Operation (Set < Reset)..... 42
  - Time Delay Operation ..... 42
  - Pump Alternation Control Operation ..... 43
  - Relay Sampling Operation ..... 43
- Relay Operation Details..... 44**
  - Overview ..... 44
  - Relays Auto Initialization..... 44
  - Fail-Safe Operation..... 44
  - Front Panel LEDs..... 44
  - Latching and Non-Latching Relay Operation ..... 44
  - Non-Latching Relay (RULto) ..... 45
  - Non-Latching Relay with Manual Reset (R-nRn)..... 45
  - Latching Relay (LRcH)..... 45
  - Latching Relay with Clear (LR-CLR)..... 45
  - Acknowledging Relays..... 46
  - Pump Alternation Control Applications (RLtErn) ..... 46
  - Setting Up the Interlock Relay (Force On) Feature ..... 47
- Scaling the 4-20 mA Analog Output (Rout)..... 48**
- Reset Menu (rESEt) ..... 48**
- Manual Control Menu (LontRL) ..... 48**
- Setting Up the Password (PR55) ..... 49**
  - Protecting or Locking the Meter ..... 49
  - Making Changes to a Password Protected Meter ..... 49
  - Disabling Password Protection ..... 49
- Advanced Features Menu..... 50**
  - Advanced Features Menu & Display Messages..... 50
  - Noise Filter (FiltEr) ..... 51
  - Noise Filter Bypass (bYPR55)..... 51
  - Rounding Feature (round)..... 51
  - Modbus® RTU Serial Communications (SEr,RL)..... 51
  - Select Menu (SELEct)..... 52
  - Input Signal Conditioning (Funcctn)..... 52
  - Low-Flow Cutoff (LwFF)..... 53
  - Analog Output Programming (RoutPr) ..... 53
  - Programmable Function Keys User Menu (u5Er)..... 54
  - Tare (tRrE)..... 55
  - Internal Source Calibration (tRL) ..... 55
- Meter Operation ..... 56**
  - Button Operation ..... 56**
  - SafeTouch Buttons ..... 57**
  - Function Keys Operation ..... 57**
  - Digital Inputs Operation ..... 57**
  - Maximum/Minimum Readings..... 57**
- Troubleshooting ..... 58**
  - Diagnostics Menu (d,RL)..... 58**
    - Testing the Display LEDs..... 58
    - Determining Software Version ..... 58
  - Reset Meter to Factory Defaults ..... 58**
    - Factory Defaults & User Settings ..... 59
  - Troubleshooting Tips ..... 60**

## Table of Figures

Figure 1. Enclosure Dimensions – Front View.....	22
Figure 2. Enclosure Dimensions – Side Cross Section View .....	22
Figure 3. Transmitter Supply Voltage Selection .....	25
Figure 4. Integrated PROVu Required Connections .....	25
Figure 5. PROVu Electronics Module Layout .....	26
Figure 6. USB Connection .....	26
Figure 7. Power Connections .....	27
Figure 8. Transmitter Powered by Internal Supply .....	27
Figure 9. Transmitter Powered by External Supply or Self-Powered.....	27
Figure 10. Voltage Input Connections .....	27
Figure 11. Relay Connections .....	27
Figure 12. AC and DC Loads Protection.....	28
Figure 13. Low Voltage DC Loads Protection .....	28
Figure 14. RS-485 Connections.....	28
Figure 15. Three-Wire RS-485 Connections .....	28
Figure 16. Digital Input and Output Connections .....	29
Figure 17. F4 Digital Input Connections .....	29
Figure 18. 4-20 mA Output Connections .....	29
Figure 19. Analog Output Supply Powering Other Devices.....	29
Figure 20. Interlock Connections .....	30

## Introduction

The ProtEX-MAX PD8-6000 is an explosion-proof, multi-purpose, easy to use, digital process meter ideal for level, flow, temperature, pressure, or any other process application. The meter features a dual-line display, with a main display 0.60" (15 mm) high, and a second display of 0.46" (12 mm) high superluminous LED digits, which can be read in any lighting condition, including direct sunlight. The meter is housed in a die-cast aluminum, field-mountable, NEMA 4X/IP68 rated enclosure for convenient indoor and outdoor installation.

The meter accepts current and voltage signals (e.g. 4-20 mA, 0-10 V) that can be scaled by the user for any application. In addition, the analog input can be scaled to display the process in two different scales; for example, the main display could indicate level in feet and the second display could indicate the volume in gallons.

The ProtEX-MAX is available in two configurations: display only and fully loaded. Both versions include a 24 VDC power supply to power the transmitter. A fully loaded ProtEX-MAX PD8-6000-6H7 meter comes with four SPDT relays, a 4-20 mA output, five digital inputs and four digital outputs, and RS-485 serial communications.

The four relays can be used for alarm indication or process control applications such as pump alternation control. The 4-20 mA isolated output, Modbus® RTU serial communications, and digital I/O features make the ProtEX-MAX an excellent addition to any system.

## SafeTouch Buttons

To make it possible to program and operate the ProtEX-MAX in a hazardous area, the programming buttons that are located behind the glass window can be operated without removing the cover by using the SafeTouch through-glass buttons. The operator puts their finger on the glass over the button and the button is actuated.



To learn more about SafeTouch buttons, see this video:

[predig.com/videos/Safetouch\\_Buttons](http://predig.com/videos/Safetouch_Buttons)

## Ordering Information

### 85-265 VAC Models

Model	Standard Features	Options Installed
<a href="#">PD8-6000-6H0</a>	5 Digital Inputs, 4 Digital Outputs, RS-485 Communications	No options
<a href="#">PD8-6000-6H7</a>		4 relays 4-20 mA output

### 12-24 VDC Models

Model	Standard Features	Options Installed
<a href="#">PD8-6000-7H0</a>	5 Digital Inputs, 4 Digital Outputs, RS-485 Communications	No options
<a href="#">PD8-6000-7H7</a>		4 relays 4-20 mA output

### Accessories

Model	Description
<a href="#">PDA0001</a>	3/4" M-NPT to F-M20 Reducer
<a href="#">PDA0002</a>	3/4" M-NPT to 1/2" F-NPT Reducer
<a href="#">PDAPLUG75</a>	3/4" Metal Conduit/Stopping Plug
<a href="#">PDA-SSTAG</a>	Custom Stainless Steel Tag (see website for convenient ordering form)
<a href="#">PDA6848</a>	2" U-Bolt Kit Zinc Plated Steel
<a href="#">PDA6848-SS</a>	2" U-Bolt Kit Stainless Steel

## Helpful Videos

There are several videos that will help you get a better understanding of the features and functionality of the ProtEX-MAX products. Since the ProtEX-MAX meters have the same general features and functionality of the ProVu meters, appropriate videos for the ProVu meter are also included.

### ProtEX-MAX Products Overview

Learn about the complete line of ProtEX-MAX products.



[predig.com/videos/ProtEXMAX\\_Overview](http://predig.com/videos/ProtEXMAX_Overview)

### MeterView Pro Programming Software

Learn how easy it is to program the ProVu (ProtEX-MAX) process meter using MeterView Pro software.



[predig.com/videos/MVPro\\_SW](http://predig.com/videos/MVPro_SW)

### MeterView Pro Software Demonstration

Learn how easy it is to program Precision Digital's ProVu (ProtEX-MAX) process meter for a level application using MeterView Pro PC-based programming software.

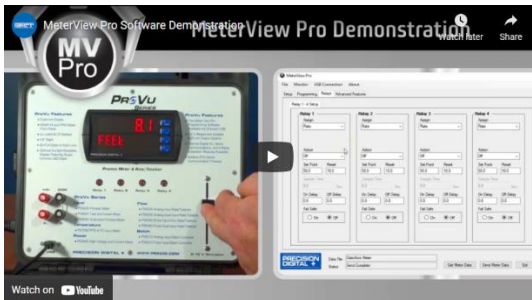

[predig.com/videos/MVPro\\_Demo](http://predig.com/videos/MVPro_Demo)

### Connect to PC for Programming

Learn how to connect a ProVu (ProtEX-MAX) process meter to your PC and install free MeterView Pro programming software.



[predig.com/videos/PC\\_Connect](http://predig.com/videos/PC_Connect)

### 4-20 mA Connections

This Tech Tips video shows how to make connections to power the transmitter with the ProVu's (ProtEX-MAX's) 24 VDC power supply.



[predig.com/videos/4-20\\_mA\\_Connections](http://predig.com/videos/4-20_mA_Connections)

### Use ProtEX-MAX for Pump Control

Learn how to use the ProVu (ProtEX-MAX) meter as an explosion-proof pump controller. See how the four relays can be used to alternate two pumps and provide high and low alarms.



[predig.com/videos/PumpControl](http://predig.com/videos/PumpControl)

# Key Features

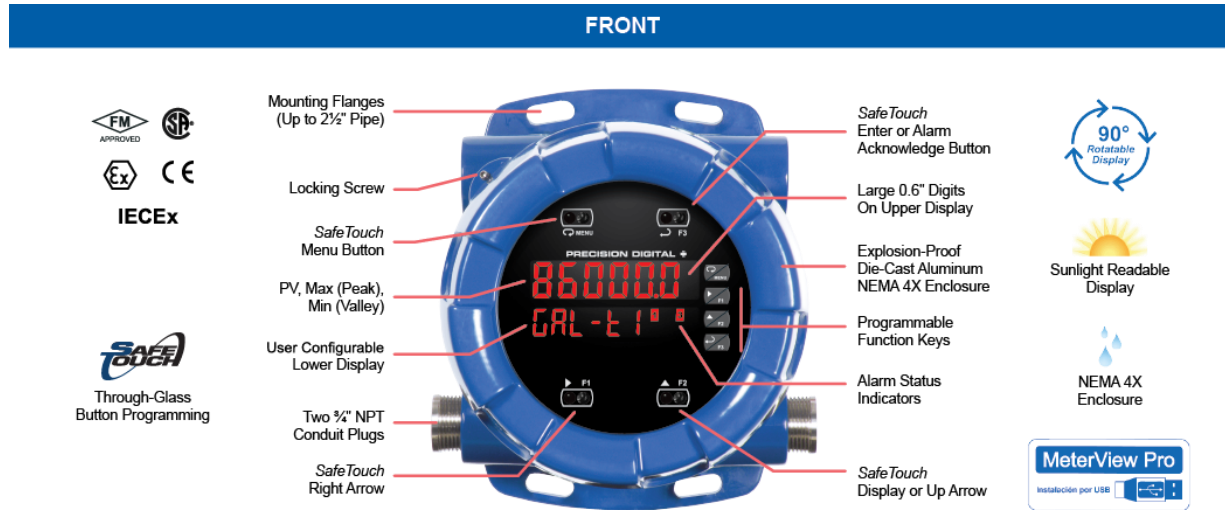

## CONNECTIONS

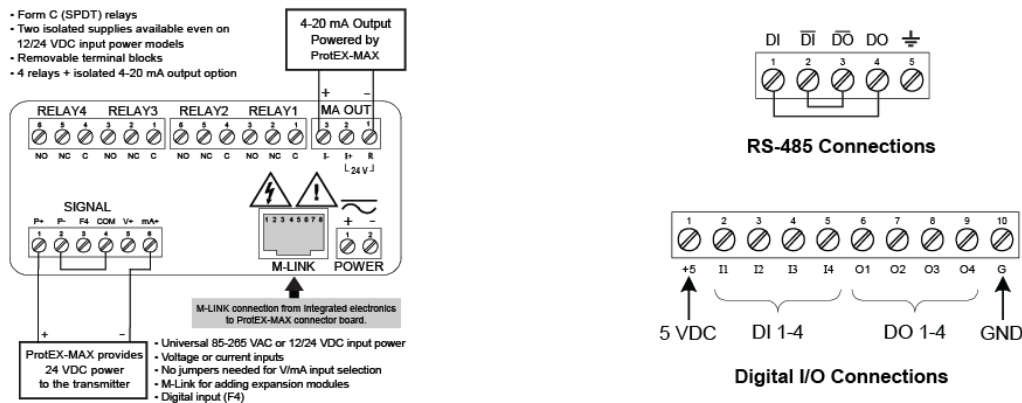

Connections for PD8-6000-6H7 & PD8-6000-7H7

## The Only Explosion-Proof Process Meter You Will Ever Need

Front, back and in between, the PD8-6000 ProtEX-MAX explosion-proof process meter boasts specifications, features and functionality that make it the only hazardous area process meter you will ever need. The front panel push-buttons can even be operated in a hazardous area without removing the cover by using the SafeTouch through-glass feature.

The PD8-6000 has all the same features as our PD6000 1/8 DIN process meter, but it is not just a meter stuffed in an explosion-proof enclosure like many of our competitors offer. The PD8-6000 is approved as a complete product by FM and CSA and also carries IECEx approvals. Besides being suitable for hazardous areas, the number one feature that makes the PD8-6000 such a useful device is its built-in 24 VDC power supply to drive the transmitter as illustrated by the above diagram. This feature not only saves the cost of an external power supply, but also greatly simplifies wiring. In addition, there is a second 25 mA power supply provided with the 4-20 mA output option, evident also in the above diagram.

The first thing you notice about the PD8-6000 is its modern looking, rugged, die cast aluminum housing with convenient mounting flanges. Housed inside this enclosure is a dual-line, 6-digit display with high-intensity LEDs that can be read in direct sunlight. The main line can display numbers up to 999,999 and the second line can be used to indicate a tag or display the input in another scale. This makes the PD8-6000 ideal for level and other applications where displaying a big number is required.

Other key features include four relays and 4-20 mA output option, advanced signal input conditioning like automatic round horizontal tank linearization, function keys, pump alternation capability, and Modbus® RTU serial communications. Finally, all these features and capabilities can easily be programmed without removing the cover using SafeTouch buttons in a hazardous area or with free MeterView Pro PC-based software in a safe area.

## Easy Programming Methods

The ProtEX-MAX can be programmed in a hazardous area with the through-glass SafeTouch buttons without removing the cover, in a safe area with the front panel push buttons with the cover removed, or in a safe area with free, PC-based MeterView Pro software. MeterView Pro is resident on the ProtEX-MAX and is accessed by a provided USB cable, so it is by far the easiest way to program the ProtEX-MAX. The ProtEX-MAX can be calibrated either by applying a known signal or scaled by entering a desired value with the front panel buttons or MeterView Pro software. Most customers will use the scaling method because it is simpler and does not require a calibrated signal source. Selecting the input to be current or voltage is done with the front panel buttons or MeterView Pro software. Once programming is completed it can be locked with a password.

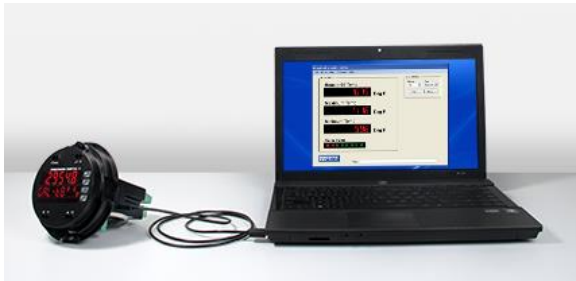

The ProtEX-MAX comes preloaded with free MeterView Pro programming software that connects and installs directly to your PC with a standard USB cable, also provided free with each instrument. This eliminates the need to insert CDs, install drivers, or download software from the internet. When you connect your ProtEX-MAX to your PC, MeterView Pro is downloaded to your PC, the software automatically selects the model you are programming, and you're ready to start programming immediately. Further simplifying the programming process, the ProtEX-MAX can be powered from the USB port, so no need to apply external power while programming your meter. In addition to programming, the software will also allow you to monitor, and datalog a ProtEX-MAX using your PC. You can also generate and save programming files for later use.

## Advanced Display Features

### Dual-Line Makes All the Difference

The main display can be programmed to indicate PV, maximum (peak), minimum (valley), alternating maximum/minimum, one of four alarm set points, or Modbus® input. The second display can be configured to display the input in a different scale, engineering units, set points, user defined messages, or simply turned off.

The ProtEX-MAX's dual-line display makes all the difference both when programming the instrument and when using it in the field. When programming the instrument, the dual-line display prompts for the needed information and also helps you keep track of where you are in the setup process. When using the instrument, the dual-line display provides more information such as displaying the input in two different scales like height and volume for a level application. We call this the Dual-Scale feature.

### Programming Assistance

The ProtEX-MAX's dual-line display makes programming the instrument much easier because the second display prompts for the needed information and also helps you keep track of where you are in the setup process.



The ProtEX-MAX is prompting for the value for Input 2 and displaying the default value of 20.00 mA. The "2" in 20.00 is brighter than the rest of the digits indicating that it is the number that will be changed by the Up arrow.



The ProtEX-MAX is now prompting for what the user wants Display 2 to be; that is the value that corresponds to 20 mA. In this case Display 2 is currently set to 95.00.

### Super-Bright Display

The ProtEX-MAX comes standard with a super-bright display, with LEDs that are visible even in direct sunlight. The display also has up to eight levels of adjustable intensity for optimum visibility in any lighting condition.

### Dual-Scale Display Feature

The ProtEX-MAX PD8-6000 has a rather unique, and very flexible dual-scale capability. This is of particular value in level applications where a second scaled display can represent the measured input in a different form (i.e. gallons & height). Both displays are independently scaled and are based on the 4-20 mA input signal. Beyond level, this function has been used for pressure & force, current & power, feet & meters, GPM & CFM, and more.

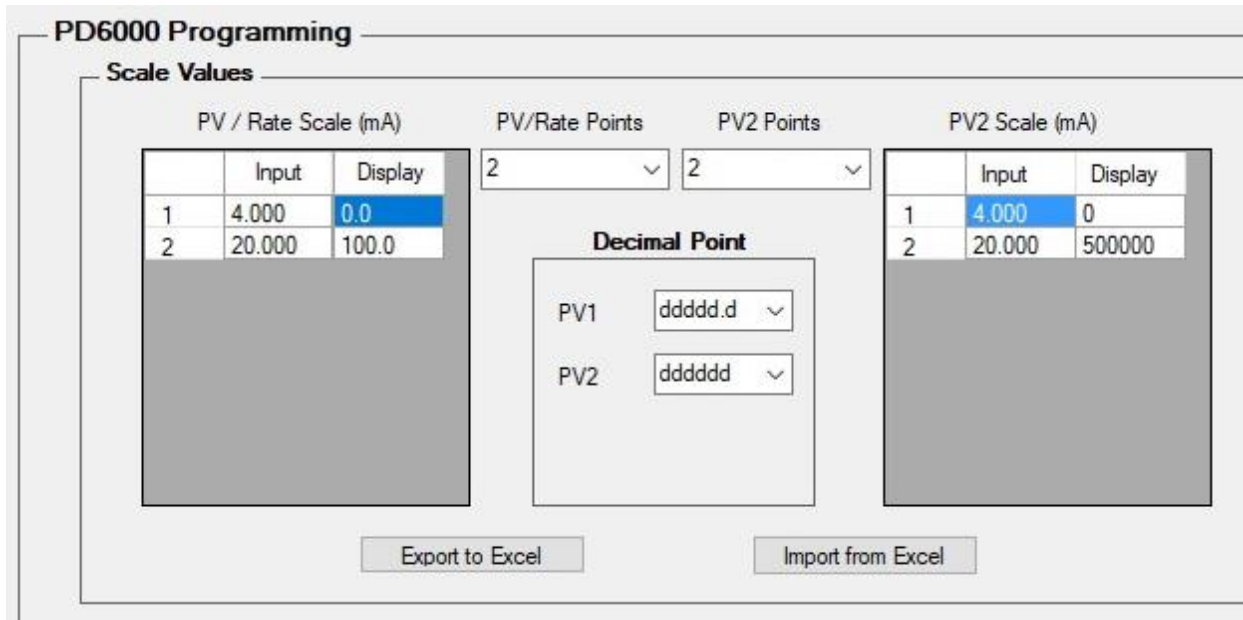

### Rounding for Even Steadier Display

The rounding feature is used to give the user a steadier display with fluctuating signals. It causes the display to round to the nearest value according to the rounding value selected (1, 2, 5, 10, 20, 50, or 100). For example, with a rounding value of 10, and an input of 12346, the display would indicate 12350.

### Other Uses for Second Line

The second line can also be used indicate units, a tag, or even a setpoint as the following pictures illustrate:

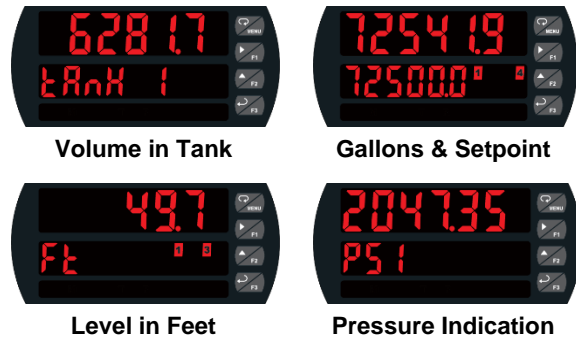

## Physical Features

The ProtEX-MAX is designed for ease-of-use in safe and hazardous applications. The ProtEX-MAX is housed in a rugged NEMA 4X explosion-proof enclosure, can operate over a wide temperature range, includes removable screw terminal connectors, has worldwide approvals for use in hazardous areas, and features through-glass buttons for easy meter operation without the need to remove the cover. All of these features are backed by a 3-year warranty.

## Super-Bright LED Display

The ProtEX-MAX features a dual-line 6-digit display with super-bright LEDs, our brightest ever. These allow the display to be read in any lighting condition, even in direct sunlight.



## SafeTouch Through-Glass Buttons

The ProtEX-MAX is equipped with four sensors that operate as through-glass buttons so that it can be programmed and operated without removing the cover (and exposing the electronics) in a hazardous area. These buttons can be disabled for security by selecting the DISABLE setting on the NO-CONTACT BUTTONS switch located on the back of the electronics module, inside the enclosure.

## Rugged, Heavy-Duty Enclosure

The ProtEX-MAX is housed in a rugged NEMA 4X, 7, & 9, IP68 die-cast aluminum enclosure, designed to withstand harsh environments in safe and hazardous areas over a wide temperature range.



## Wide Viewing Angle

Customers can't always look at the display from straight on, so the window and display module have been optimized to provide a wide viewing angle of approximately +/- 40°; nearly twice that of the competition.



## Built-In Mounting Flanges

The ProtEX-MAX is equipped with four slotted flanges for wall mounting or NPS 1½" to 2½" or DN 40 to 65 mm pipe mounting.



## Flexible Mounting & Wiring

The ProtEX-MAX features four ¾" NPT threaded conduit openings so that wiring can be routed to the most convenient conduit connection(s). Two ¾" NPT metal conduit plugs with 12 mm hex key fitting come installed.



### Rotatable Display

The ProtEX-MAX rotatable display, along with four available conduit connections, provide for numerous installation options. The display can be rotated in 90° increments. Rotate it 90° for horizontal mounting.



Vertical Mounting

Horizontal Mounting

### Perfect & Secure Fit Every Time

The internal cast rails ensure the ProtEX-MAX assembles together perfectly, quickly and securely; and everything lines up for optimal viewing every time. There are no standoffs to worry about breaking or getting out of alignment. Two spring-loaded, self-retaining, thumbscrews make the assembly a snap, while pressing the display as close to the glass as possible to improve wide angle viewing.

### Stainless Steel Tags

PDA-SSTAG is a laser etched stainless steel tag accessory for any of your Precision Digital meters. The tag features custom text for equipment identification, instruction, or whatever else is needed in your facility. Each tag comes with a stainless steel wire and lead seal for easy mounting wherever you need it.



### Removable Screw Terminals

Industrial applications require screw terminal connections for easy field wiring and the ProtEX-MAX goes one step further in convenience by making them removable also.



### USB Port MeterView Pro

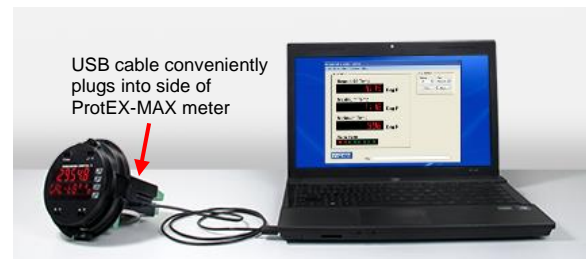

USB cable conveniently plugs into side of ProtEX-MAX meter

### Hazardous Area Approvals

The ProtEX-MAX's approvals allow it to be used in hazardous areas around the world. These include: FM Approved as Explosion-Proof / Dust-Ignition-Proof / Flame-Proof, CSA Certified as Explosion-Proof / Dust-Ignition-Proof, and ATEX and IECEx Certified as Flame-Proof.

### Wide Operating Temperature Range

The ProtEX-MAX can operate from -40 to 60°C (-40 to 140°F) meaning it can be installed in a wide variety of indoor and outdoor industrial applications. And over this range, the ProtEX-MAX will drift no more than 0.005% of calibrated span/°C max from 0 to 65°C ambient and 0.01% of calibrated span/°C max from -40 to 0°C ambient.

## Transmitter Power Supplies

### Meter Powers Transmitter

One of the most useful standard features of the PD8-6000 is its built-in isolated, 24 V @ 25 mA power supply to power the transmitter. This feature saves money by eliminating an external power supply and also simplifies wiring by reducing the number of devices in the loop. It can be configured for 5, 10, or 24 V (default) by means of a simple internal jumper. This power supply (24 V @ 25 mA) is even available on meters that are powered from DC power. To use an external power supply instead of the internal power supply, simply make connections to different terminals on the ProtEX-MAX.

The following diagram illustrates how to wire the ProtEX-MAX so it will power the transmitter:

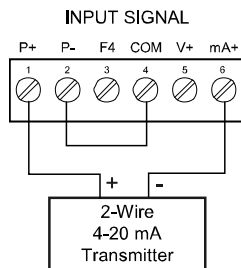

### Meter Powers 4-20 mA Output

Not only can the ProtEX-MAX power the 4-20 mA input signal, but an additional power supply of 24 V @ 25 mA is provided with the 4-20 mA output option to power the 4-20 mA output.

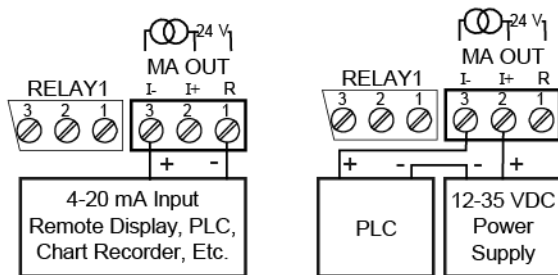

### Fuse Prevents Current Overload

Another very useful aspect of the ProtEX-MAX is that the current input is protected against current overload by a resettable fuse. The fuse limits the current to a safe level when it detects a fault condition, and automatically resets itself when the fault condition is removed.

## Input Signal Conditioning

Non-linear input signals (i.e. weirs & flumes, differential pressure, round horizontal tanks, etc.) can be linearized with the ProtEX-MAX's simple to use built-in signal input conditioning functions. These include square-root extractor, exponential linearizer, round horizontal tank linearizer, and user-customizable 32-point linearizer.

### Round Horizontal Tank Linearization

This function automatically calculates the volume in a round horizontal tank with flat ends.

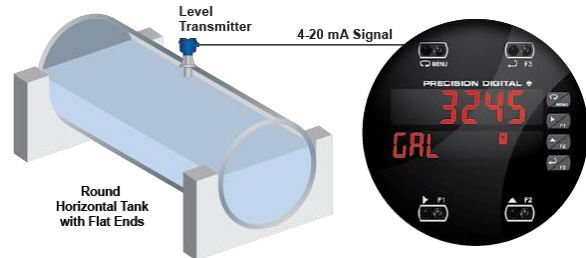

### Square Root Linearization

The square root function can be used to linearize the signal from a differential pressure transmitter and display flow rate in engineering units.

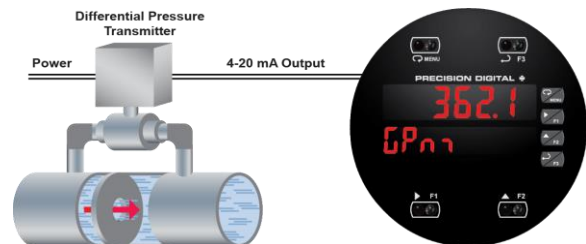

### Programmable Exponent Linearization

The programmable exponent can be used to linearize the signal from level transmitters in open-channel flow applications using weirs and flumes.

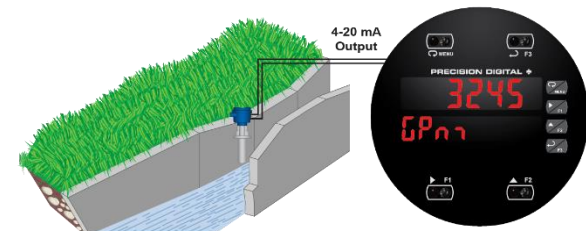

## Exp-Proof Dual-Pump Alternation

The ProtEX-MAX can be used as an explosion-proof pump controller when combined with a continuous level transmitter. The most common pump control application is shown below: controlling and alternating two pumps and providing high and low-level alarms. In addition, the ProtEX-MAX provides the 24 V to power the transmitter.

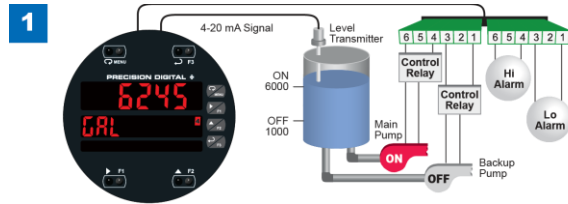

Relay #4 turns the main pump on at 6000 gallons and turns it off at 1000 gallons.

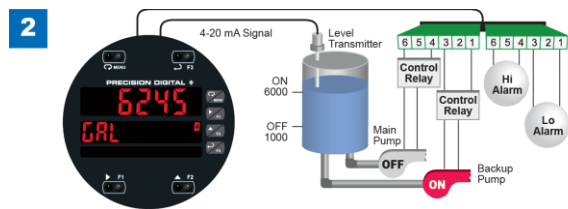

With the Pump Alternation feature activated, the next time the level reaches 6000 gallons, relay #3 transfers and starts the backup pump.

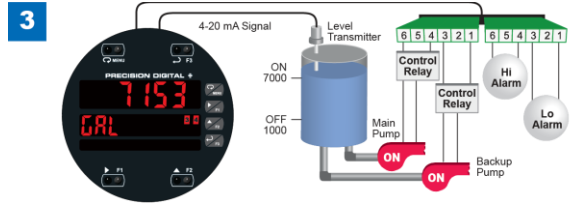

If the backup pump is not able to keep up, and the level reaches 7000 gallons, relay #4 transfers and starts the main pump as well.

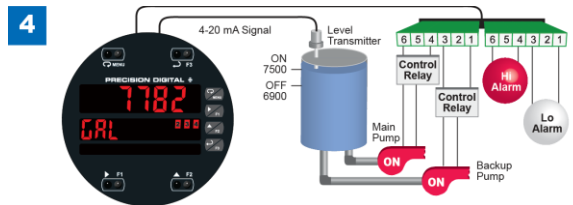

Relay #2 trips the High Level Alarm at 7500 gallons and resets at 6900 gallons.

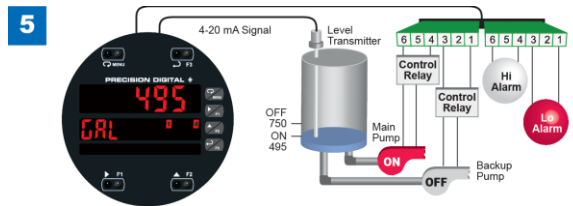

Relay #1 trips the Low Level Alarm at 495 gallons and resets at 750 gallons.



Learn how to use the ProVu (ProtEX-MAX) meter as an explosion-proof pump controller. See how the four relays can be used to alternate two pumps and provide high and low alarms.

[predig.com/videos/PumpControl](https://predig.com/videos/PumpControl)

## Useful Tools

### PD9501 Multi-Function Calibrator



This [PD9501](#) Multi-Function Calibrator has a variety of signal measurement and output functions, including voltage, current, thermocouple, and RTD.

### PD9502 Low-Cost Signal Generator



The [PD9502](#) is a low-cost, compact, simple to use 4-20 mA or 0-10 VDC signal generator. It can easily be set for 0-20 mA, 4-20 mA, 0-10 V or 2-10 V ranges. Signal adjustment is made with a one-turn knob. A 15-27 VDC wall plug is provided with the instrument. Optional USB power bank is available.

## Specifications

Except where noted all specifications apply to operation at +25°C.

### General

<b>Display</b>	Display Line 1: 0.60" (15 mm) high, red LEDs Display Line 2: 0.46" (12 mm) high, red LEDs 6 digits each (-99999 to 999999), with lead zero blanking
<b>Display Intensity</b>	Eight user selectable intensity levels. Default intensity is six.
<b>Display Update Rate</b>	5/second (200 ms)
<b>LED Status Indicators</b>	See <i>LED Status Indicators</i> on page 31 for details.
<b>Overrange</b>	Display flashes 999999
<b>Underrange</b>	Display flashes -99999
<b>Display Assignment</b>	Display Line 1: PV1, PV2, PCT, PV & units, gross weight, net & gross weight, max/min, max & min, set points, or Modbus® input Display Line 2: Same as Display Line 1; plus units, tag or turned off
<b>Programming Methods</b>	Four SafeTouch through-glass buttons when cover is installed. Mechanical buttons can be used with the cover removed. Free PC-based USB MeterView Pro programming software.
<b>Noise Filter</b>	Programmable from 2 to 199 (0 will disable filter)
<b>Filter Bypass</b>	Programmable from 0.1 to 99.9% of calibrated span
<b>Recalibration</b>	All ranges are calibrated at the factory. Recalibration is recommended at least every 12 months.
<b>Max/Min Display</b>	Max/min readings reached by the process are stored until reset by the user or until power to the meter is turned off.
<b>Rounding</b>	Select 1, 2, 5, 10, 20, 50, or 100 (e.g. rounding = 10, value = 123.45, display = 123.50)
<b>Tare</b>	Tare function zeros out the meter to remove the weight of a container. Tare function can be assigned to a function key, F4 terminal, or a digital input.
<b>Password</b>	Three programmable passwords restrict modification of programmed settings. Pass 1: Allows use of function keys and digital inputs Pass 2: Allows use of function keys, digital inputs and editing set/reset points Pass 3: Restricts all programming, function keys, and digital inputs
<b>Non-Volatile Memory</b>	All programmed settings are stored in non-volatile memory for a minimum of ten years if power is lost.

<b>Power Options</b>	85-265 VAC 50/60 Hz; 90-265 VDC, 20 W max; 12-24 VDC, 12-24 VAC, 15 W max. Powered over USB for configuration only.
<b>Fuse</b>	Required external fuse: UL Recognized, 5 A max, slow blow; up to 6 meters may share one 5 A fuse
<b>Normal Mode Rejection</b>	Greater than 60 dB at 50/60 Hz
<b>Isolation</b>	4 kV input/output-to-power line 500 V input-to-output or output-to-P+ supply
<b>Overvoltage Category</b>	Installation Overvoltage Category II: Local level with smaller transient overvoltages than Installation Overvoltage Category III
<b>Environmental</b>	T6 Class operating temperature range Ta = -40 to 60°C T5 Class operating temperature range Ta = -40 to 65°C Storage temperature range: -40 to 85°C (-40 to 185°F) Relative humidity: 0 to 90% non-condensing
<b>Max Power Dissipation</b>	Maximum power dissipation limited to 15.1 W
<b>Connections</b>	Power, signal, relays, mA out: Removable screw terminal blocks accept 12 to 22 AWG wire RS-485: Removable screw terminal block accepts 16 to 30 AWG wire Digital I/O: Removable screw terminal blocks accept 16 to 30 AWG wire
<b>Enclosure</b>	Explosion-proof die cast aluminum with glass window, corrosion resistant epoxy coating, color: blue NEMA 4X, 7, & 9, IP68 Default conduit connections: Four ¾" NPT threaded conduit openings and two ¼" NPT metal conduit plugs with 12 mm hex key fitting installed. Additional conduit opening configurations may be available; verify quantity and sizes on specific device labeling during installation.
<b>Mounting</b>	Wall Mounting: Four (4) mounting holes provided for mounting meter to wall. See <i>Wall Mounting Instructions</i> on page 22 for additional details. Pipe Mounting: Optional pipe mounting kit (PDA6848) allows for pipe mounting. Sold separately. See <i>Pipe Mounting Instructions</i> on page 23 for additional details.
<b>Tightening Torque</b>	Power, signal, relays, mA out terminals: 5 lb-in (0.56 Nm) Digital I/O and RS-485: 2.2 lb-in (0.25 Nm)
<b>Overall Dimensions</b>	6.42" x 7.97" x 8.47" (W x H x D) (163 mm x 202 mm x 215 mm)
<b>Weight</b>	16.0 lbs (7.26 kg)
<b>Warranty</b>	3 years parts & labor. See Warranty Information and Terms & Conditions on <a href="http://www.predig.com">www.predig.com</a> for complete details.

## Process Inputs

<b>Inputs</b>	Field selectable: 0-20 mA, 4-20 mA ±10 V (0-5 V, 1-5 V, 0-10 V) Modbus® PV (Slave)	
<b>Isolated Transmitter Power Supply</b>	Terminals P+ & P-: 24 VDC ± 10%. selectable for 24, 10, or 5 VDC supply (internal jumper J4) All models transmitter supply rated @ 25mA max	
<b>Accuracy</b>	±0.03% of calibrated span ±1 count, square root & programmable exponent accuracy range: 10-100% of calibrated span	
<b>Temperature Drift</b>	0.005% of calibrated span/°C max from 0 to 65°C ambient, 0.01% of calibrated span/°C max from -40 to 0°C ambient	
<b>Input Signal Conditioning</b>	Linear, square root, programmable exponent, or round horizontal tank volume calculation	
<b>Multi-Point Linearization</b>	2 to 32 points for PV or PV1 2 to 8 points for PV2 (Dual-scale Level feature)	
<b>Programmable Exponent</b>	User selectable from 1.0001 to 2.9999 for open channel flow	
<b>Round Horizontal Tank</b>	Diameter & Length: 999.999 inch or cm calculates volume in gallons or liters respectively	
<b>Low-Flow Cutoff</b>	0.1 to 999,999 (0 disables cutoff function) Point below at which display always shows zero	
<b>Decimal Point</b>	Up to five decimal places or none: dddddd, dddddd, dddd, ddd, dd, or dddddd	
<b>Calibration Range</b>	Input Range	Minimum Span Input 1 & 2
	4-20 mA	0.15 mA
	±10 V	0.10 V
	An error message will appear if the input 1 and input 2 signals are too close together	
<b>Input Impedance</b>	Voltage ranges: greater than 500 kΩ Current ranges: 50 - 100 Ω (depending on internal resettable fuse impedance)	
<b>Input Overload</b>	Current input protected by an internal resettable fuse, 30 VDC max. Fuse resets automatically after fault is removed.	
<b>HART Transparency</b>	The meter does not interfere with existing HART communications; it displays the 4-20 mA primary variable and it allows the HART communications to pass through without interruption. The meter is not affected if a HART communicator is connected to the loop. The meter does not display secondary HART variables.	

## Relays

<b>Rating</b>	4 SPDT (Form C) internal and rated 3 A @ 30 VDC and 125/250 VAC resistive load; 1/14 HP (≈ 50 W) @ 125/250 VAC for inductive loads
<b>Noise Suppression</b>	Noise suppression is recommended for each relay contact switching inductive loads. See <i>Switching Inductive Loads</i> on page 28 for details.
<b>Deadband</b>	0-100% of span, user programmable
<b>High or Low Alarm</b>	User may program any alarm for high or low trip point. Unused alarm LEDs and relays may be disabled (turn off).
<b>Relay Operation</b>	<ul style="list-style-type: none"> <li>• Automatic (non-latching) and/or manual reset</li> <li>• Latching (requires manual acknowledge) with or without clear</li> <li>• Pump alternation control (2-4 relays)</li> <li>• Sampling (based on set point and time)</li> <li>• Off (disable unused relays and enable Interlock feature)</li> <li>• Manual on/off control mode</li> </ul>
<b>Relay Reset (Acknowledge)</b>	User selectable via front panel button, F4 digital input, external contact closure on digital inputs, or through serial communications
<b>Time Delay</b>	0 to 999.9 seconds, on & off relay time delays. Programmable and independent for each relay.
<b>Fail-Safe Operation</b>	Programmable and independent for each relay <b>Note:</b> <i>Relay coil is energized in non-alarm condition. In case of power failure, relay will go to alarm state.</i>
<b>Auto Initialization</b>	When power is applied to the meter, relays will reflect the state of the input to the meter

## USB Connection

<b>Function</b>	Programming only
<b>Compatibility</b>	USB 2.0 Standard, Compliant
<b>Connector Type</b>	Micro-B receptacle
<b>Cable</b>	USB A Male to Micro-B Cable
<b>Driver</b>	Microsoft® Windows® XP/Vista/7/8/10
<b>Power</b>	USB port provides power to the meter. <b>DO NOT</b> apply AC or DC power to the meter while the USB port is in use.

## Isolated 4-20 mA Transmitter Output Option

<b>Output Source</b>	Process variable (PV), max, min, set points 1-4, Modbus® input, or manual control mode		
<b>Scaling Range</b>	1.000 to 23.000 mA for any display range		
<b>Calibration</b>	Factory calibrated: 4.000 to 20.000 = 4-20 mA output		
<b>Analog Out Programming</b>	23.000 mA maximum for all parameters: Overrange, underrange, max, min, and break		
<b>Accuracy</b>	± 0.1% of span ± 0.004 mA		
<b>Temperature Drift</b>	0.4 µA/°C max from 0 to 65°C ambient, 0.8 µA/°C max from -40 to 0°C ambient <i>Note: Analog output drift is separate from input drift.</i>		
<b>Isolated Transmitter Power Supply</b>	Terminals I+ & R: 24 VDC ±10%. May be used to power the 4-20 mA output or other devices. All models rated @ 25 mA max.		
<b>External Loop Power Supply</b>	35 VDC maximum		
<b>Output Loop Resistance</b>	Power supply	Minimum	Maximum
	24 VDC	10 Ω	700 Ω
	35 VDC (external)	100 Ω	1200 Ω

## RS-485 Serial Communications

<b>Compatibility</b>	EIA-485
<b>Connectors</b>	Removable screw terminal connector
<b>Max Distance</b>	3,937' (1,200 m) max
<b>Status Indication</b>	Separate LEDs for Power (P), Transmit (TX), and Receive (RX)

## Modbus® RTU Serial Communications

<b>Slave Id</b>	1 – 247 (Meter address)
<b>Baud Rate</b>	300 – 19,200 bps
<b>Transmit Time Delay</b>	Programmable between 0 and 199 ms
<b>Data</b>	8 bit (1 start bit, 1 or 2 stop bits)
<b>Parity</b>	Even, Odd, or None with 1 or 2 stop bits
<b>Byte-To-Byte Timeout</b>	0.01 – 2.54 second
<b>Turn Around Delay</b>	Less than 2 ms (fixed)
<b>Note:</b>	Refer to the <i>ProtEX-MAX Modbus® Register Tables</i> located at <a href="http://www.prediq.com">www.prediq.com</a> for details.

## Digital Input (F4)

<b>Function</b>	Remote operation of front-panel buttons, acknowledge/reset relays, reset max/min values. See <i>Function Keys &amp; Digital I/O Available Settings</i> on page 54 for a complete list of capabilities.
<b>Contacts</b>	3.3 VDC on contact. Connect normally open contacts across F4 to COM
<b>Logic Levels</b>	Logic High: 3 to 5 VDC Logic Low: 0 to 1.25 VDC

## Digital Inputs & Outputs

<b>Function</b>	Terminals provided for remote operation of all four programming / operation buttons. Other uses include acknowledge/reset relays and reset max/min values. See <i>Function Keys &amp; Digital I/O Available Settings</i> on page 54 for a complete list of capabilities.
<b>Channels</b>	4 digital inputs & 4 digital outputs
<b>Digital Input Logic High</b>	3 to 5 VDC
<b>Digital Input Logic Low</b>	0 to 1.25 VDC
<b>Digital Output Logic High</b>	3.1 to 3.3 VDC
<b>Digital Output Logic Low</b>	0 to 0.4 VDC
<b>Source Current</b>	10 mA maximum output current
<b>Sink Current</b>	1.5 mA minimum input current
<b>+5 V Terminal</b>	To be used as pull-up for digital inputs only. Connect normally open push buttons across +5 V & DI 1-4.

### WARNING

- **DO NOT** use +5 V terminal to power external devices.

## MeterView Pro Software

<b>Availability</b>	Download directly from meter or from <a href="http://www.prediq.com/download_software">www.prediq.com/download_software</a>
<b>System Requirements</b>	Microsoft® Windows® XP/Vista/7/8/10
<b>Communications</b>	USB 2.0 (for programming only) (Standard USB A to USB Type B) RS-485 to USB converter (programming, monitoring, and data logging)
<b>Configuration</b>	Configure meters one at a time
<b>Power</b>	USB port provides power to the meter. <b>DO NOT</b> apply AC or DC power to the meter while the USB port is in use.

## Compliance Information

### Electromagnetic Compatibility

<b>Emissions</b>	EN 55022 Class A ITE emissions requirements
Radiated Emissions	Class A
AC Mains Conducted Emissions	Class A
<b>Immunity</b>	EN 61326-1 Measurement, control, and laboratory equipment EN 61000-6-2 EMC heavy industrial generic immunity standard
RFI - Amplitude Modulated	80 -1000 MHz 10 V/m 80% AM (1 kHz) 1.4 - 2.0 GHz 3 V/m 80% AM (1 kHz) 2.0 - 2.7 GHz 1 V/m 80% AM (1 kHz)
Electrical Fast Transients	±2kV AC mains, ±1kV other
Electrostatic Discharge	±4kV contact, ±8kV air
RFI - Conducted	10V, 0.15-80 MHz, 1kHz 80% AM
AC Surge	±2kV Common, ±1kV Differential
Surge	1KV (CM)
Power-Frequency Magnetic Field	30 A/m 70%V for 0.5 period
Voltage Dips	40%V for 5 & 50 periods 70%V for 25 periods
Voltage Interruptions	<5%V for 250 periods

**Note:** Testing was conducted on meters with cable shields grounded at the point of entry representing installations designed to optimize EMC performance.

## Product Ratings and Approvals

<b>FM</b>	Enclosure: Type 4X; IP66 Class I, Division 1, Groups B, C, D Class II, Division 1, Groups E, F, G Class III, Division 1, T5/T6 Class I, Zone 1, AEx d, IIC Gb T5/T6 Zone 21, AEx tb IIIC T90°C; Ta -40°C to +65°C T6 Ta = -40°C to +60°C; T5 Ta = -40°C to +65°C Certificate Number: 3047283
<b>CSA</b>	Class I, Division 1, Groups B, C, D Class II, Division 1, Groups E, F, G Class III, Division 1 Class I Zone 1 Ex d IIC Zone 21 Ex tb IIIC T90°C -40°C < Tamb. < +60° C; Temperature Code T6 -40°C < Tamb. < +65° C; Temperature Code T5 Enclosure Type 4X & IP66 Certificate Number: 2531731
<b>ATEX</b> 	II 2 G D Ex d IIC T* Gb Ex tb IIIC T90°C Db IP68 Ta = -40°C to +*°C *T6 = -40°C to +60°C *T5 = -40°C to +65°C Certificate number: Sira 12ATEX1182
<b>IECEx</b>	Ex d IIC T* Gb Ex tb IIIC T90°C Db IP68 Ta = -40°C to +*°C *T6 = -40°C to +60°C *T5 = -40°C to +65°C Certificate Number: IECEx SIR 12.0073

### Special Conditions for Safe Use:

Use suitably certified and dimensioned cable entry device and/or plug. The equipment shall be installed such that the supply cable is protected from mechanical damage. The cable shall not be subjected to tension or torque. If the cable is to be terminated within an explosive atmosphere, then appropriate protection of the free end of the cable shall be provided. Cable must be suitable for 90°C.

### Year of Construction

This information is contained within the serial number with the first four digits representing the year and month in the YYYYMM format.

**For European Community:** The ProtEX-MAX must be installed in accordance with the ATEX directive 94/9/EC, and the product certificate Sira 12ATEX1182.

## EU Declaration of Conformity

EU Declaration of Conformity is available in the Documentation CD provided with the product under the **EU DoC** menu.

## Safety Information

### ⚠ CAUTION

- Read complete instructions prior to installation and operation of the meter.

### ⚠ WARNINGS

- Risk of electric shock or personal injury.
- Hazardous voltages exist within enclosure. Installation and service should be performed only by trained service personnel.

## Installation

*Install in accordance with applicable local and national regulations (e.g. NEC).*

### For Installation in USA

The ProtEX-MAX must be installed in accordance with the National Electrical Code (NEC) NFPA 70.

### For Installation in Canada

The ProtEX-MAX must be installed in accordance with the Canadian Electrical Code CSA 22.1. All power supplies below 36 V and input circuits must be derived from a CSA Approved Class 2 source.

### For European Community

The ProtEX-MAX must be installed in accordance with the ATEX directive 94/9/EC and the product certificate Sira 12ATEX1182.

### ⚠ WARNINGS

- Disconnect from supply before opening enclosure.
- Keep cover tight while circuits are live.
- Conduit seals must be installed within 18" (450mm) of the enclosure or within 2" (50mm) for Zone installations.

Wiring connectors are accessed by opening the enclosure. To access electrical connectors, remove the 2 captive screws and then remove the electronics module. Connectors are on the rear of the electronics module.

## Unpacking

Remove the meter from box. Inspect the packaging and contents for damage. Report damages, if any, to the carrier.

If any part is missing or the meter malfunctions, please contact your supplier or the factory for assistance.

## Pre-Installed Conduit Plugs

The ProtEX-MAX is supplied with two pre-installed conduit plugs for installations that do not require the use of all four conduit entries. The conduit/stopping plugs include an internal hexagonal socket recess for removal. The conduit plugs and their factory installation are included in all hazardous area approvals of this product.

### ⚠ WARNING

- In hazardous areas, conduit and conduit/stopping plugs require the application of non-setting (solvent free) thread sealant. It is critical that all relevant hazardous area guidelines be followed for the installation or replacement of conduit or plugs.

## Cover Jam Screw



The cover jam screw should be properly installed once the meter has been wired and tested in a safe environment. The cover jam screw is intended to prevent the removal of the meter cover in a hazardous environment without the use of tools. Using a M2 hex wrench, turn the screw clockwise until the screw contacts the meter. Turn the screw an additional 1/4 to 1/2 turn to secure the cover.

### ⚠ CAUTION

- Excess torque may damage the threads and/or wrench.

## Mounting

The ProtEX-MAX has four slotted mounting flanges that may be used for pipe mounting or wall mounting.

Refer to *Figure 1* and *Figure 2* below.

**⚠ WARNING**

- Do not attempt to loosen or remove flange bolts while the meter is in service.

## Mounting Dimensions

All units: inches (mm)

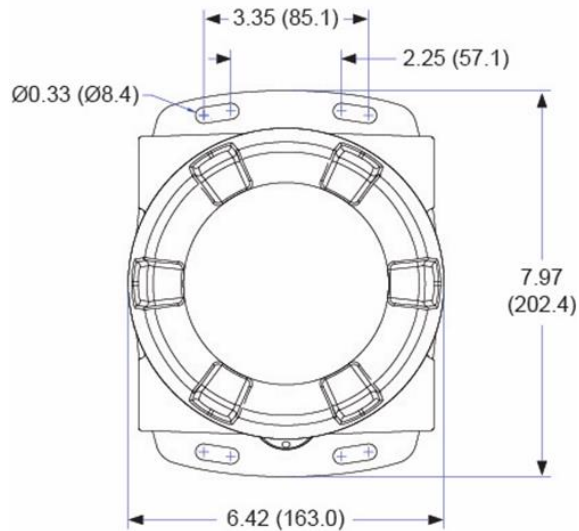

Figure 1. Enclosure Dimensions – Front View

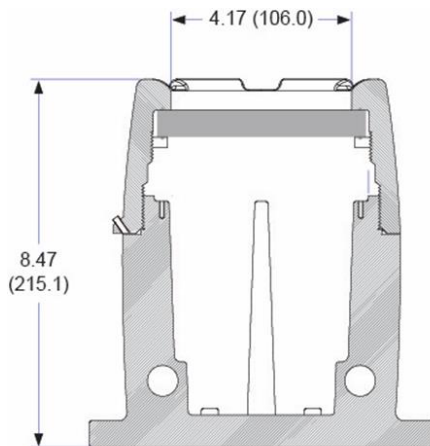

Figure 2. Enclosure Dimensions – Side Cross Section View

## Wall Mounting Instructions

The meter can be mounted to any wall or flat surface using the four provided mounting holes located in the cast-in flanges. In addition, the internal electronic assembly can be rotated to allow the enclosure to be mounted in any position. To mount the meter to a wall, follow these instructions:

- Prepare a section of wall approximately 7" x 8.5" (178 mm x 216 mm) for meter mounting by marking with a pencil the mounting holes (shown in *Figure 1*) on the wall.
- Select the appropriate mounting screws for the mounting surface to be used. The mounting holes diameter is shown on *Figure 1*.
- Note:** Mounting screws are not included.
- Using a drill bit slightly smaller than the girth of the mounting screws, pre-drill holes at the mounting locations previously marked.
- Insert mounting screws into the four mounting holes and screw them into the pre-drilled holes.

ENCLOSURE  
**CAD**  
DIMENSIONAL DRAWINGS

Download free 3-D CAD files of these instruments to simplify your drawings!

[predig.com/documentation-cad](http://predig.com/documentation-cad)

### Pipe Mounting Instructions



### Vertical Pipe Mounting

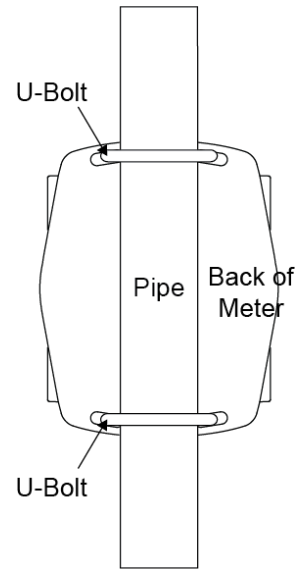

The meter can also be mounted to a pipe using an optional U-Bolt kit. This kit includes two U-bolts, the necessary hardware, and is available in zinc plated steel ([PDA6848](#)) and 316 stainless steel ([PDA6848-SS](#))

### Horizontal Pipe Mounting

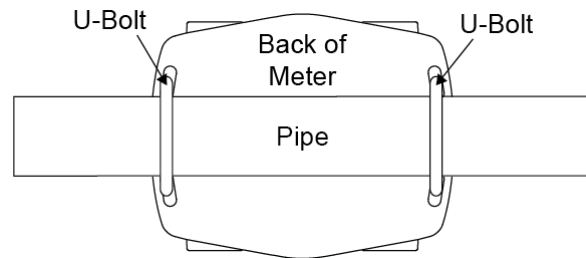

To mount the meter using a U-Bolt kit, follow these instructions:

- Orient the groove on the back of the instrument with the pipe and secure it to the pipe with the two U-bolts and hardware provided.



## Installation Overview

We recommend the following sequence for getting the meter into service:

1. **DO NOT** apply AC or DC power to the meter.
2. Connect the meter to the PC with the USB cable provided. **DO NOT** use a different USB cable.
3. If MeterView Pro (MVPPro) is already installed in your computer, then the program will launch automatically in most systems. If the program does not start automatically, double-click on the MVPPro icon.
4. If MVPPro is not installed, follow the instructions provided below.
5. Use MVPPro to configure the meter for your application.
6. Disconnect the USB cable from the meter.
7. Apply power and signal and check operation of the meter.
8. Install the meter and put into service.
9. Make any programming adjustments using the programming buttons.

## MeterView Pro Software

The easiest and quickest way to program your ProtEX-MAX meter is to use the FREE MeterView Pro programming software. This software is loaded into the meter and connects and installs directly to your PC with the USB cable provided. **DO NOT** use a different USB cable. We recommend that the first thing you do after taking the meter out of the box is connect the ProtEX-MAX to your PC with the provided USB cable. **DO NOT** apply AC or DC power to the meter while your PC is connected to the meter as it will disrupt the USB connection. It is not necessary to apply an input signal.

MeterView Pro programming software is intuitive, and most customers can get their meter programmed as they like without even looking in the manual.

Watch MeterView Pro Software Video at [www.prediq.com/meterviewpro](http://www.prediq.com/meterviewpro)

## MeterView Pro Installation

1. Connect one end of the provided USB cable to the meter and the other end to the computer. The computer will automatically install the driver software it needs to talk to the meter. Follow the on-screen instructions and allow sufficient time for the process to complete. This can take a few minutes. If the process is interrupted, then it could leave the system in an unstable condition.

### ⚠ WARNINGS

- Only one meter may be connected at a time. Attaching multiple meters will cause a conflict with the meter software.
- **DO NOT** apply AC or DC power to the meter when using the USB connection.
- The meter should only be connected to a computer while it is located in a safe area.

2. Once the driver is installed, an AutoPlay dialog should appear for the drive "MAINSTAL." Click "Open folder to view files."

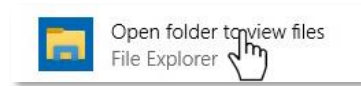

If the computer does not display an AutoPlay dialog for the drive "MAINSTAL," you should open My Computer and double-click on the drive labeled "MAINSTAL."

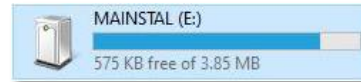

3. Double-click on the file named "MAStart." The program will open a few windows and install two programs on your computer. Simply follow the on-screen instructions until you see one of the dialogs below. If you receive a "User Account Control" warning, click "Yes."

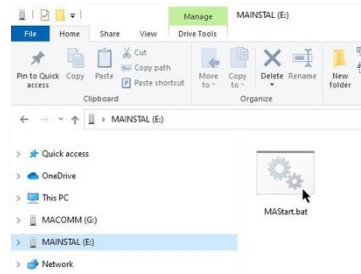

4. If there is an update available, click the "Update" button to install the new version. Otherwise, click "Configure" to begin programming your meter.

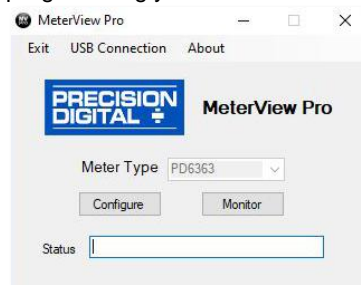

**Note:** If you decide to update your MeterView Pro software, once the installation has completed, you will be asked if you want to update the setup files located on the meter itself. This way, you will always have the most current version on the meter for future installs.

### ⚠ WARNING

- **DO NOT** unplug the meter while the new installation files are being written to it. The meter will display  $\mu$  r E during the process and you will receive an on-screen notification once the process is complete.

## Transmitter Supply Voltage Selection (P+, P-)

All meters, including models equipped with the 12-24 VDC power option, are shipped from the factory configured to provide 24 VDC power for the transmitter or sensor.

If the transmitter requires 5 or 10 VDC excitation, the internal jumper J4 must be configured accordingly.

To access the voltage selection jumper:

1. Remove all the wiring connectors.
2. Unscrew the back cover.
3. Slide out the back cover by about 1 inch.
4. Configure the J4 jumper, located behind the input signal connector, for the desired excitation voltage as shown.

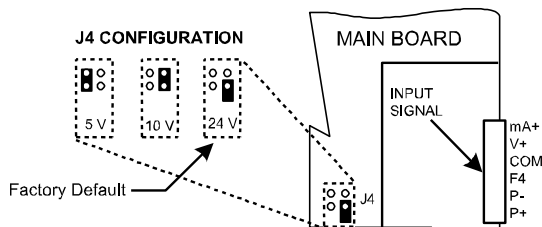

Figure 3. Transmitter Supply Voltage Selection

## Connections

All connections are made to removable screw terminal connectors located at the rear of the meter.

### CAUTION

- Use copper wire with 60°C or 60/75°C insulation for all line voltage connections. Observe all safety regulations. Electrical wiring should be performed in accordance with all applicable national, state, and local codes to prevent damage to the meter and ensure personnel safety.

### WARNINGS

- Observe all safety regulations. Electrical wiring should be performed in accordance with all agency requirements and applicable national, state, and local codes to prevent damage to the meter and ensure personnel safety.
- Static electricity can damage sensitive components.
- Observe safe handling precautions for static-sensitive components.
- Use proper grounding procedures/codes.
- If the instrument is installed in a high voltage environment and a fault or installation error occurs, high voltage may be present on any lead or terminal.
- Follow all fusing and wiring precautions requirements for the instrument integrated to the PD8 Series model number being connected.

To access the connectors, remove the enclosure cover and unscrew the two captive screws that fasten the electronics module. Signal connections are made to de-pluggable connectors on the back of the electronics module.

Some connectors may be provided already connected. These connections are required for proper operation of the ProtEX-MAX and should not be removed unless instructed to by this manual.

Wires marked as being used for testing purposes should be removed.

Grounding connections are made to the two ground screws provided on the base – one internal and one external.

After all connections have been completed and verified, apply power to the unit.

## Required & Factory Wired Connection

The ProtEX-MAX comes with a pre-wired connection. This connection is detailed below and must be maintained in order for the instrument to function properly.

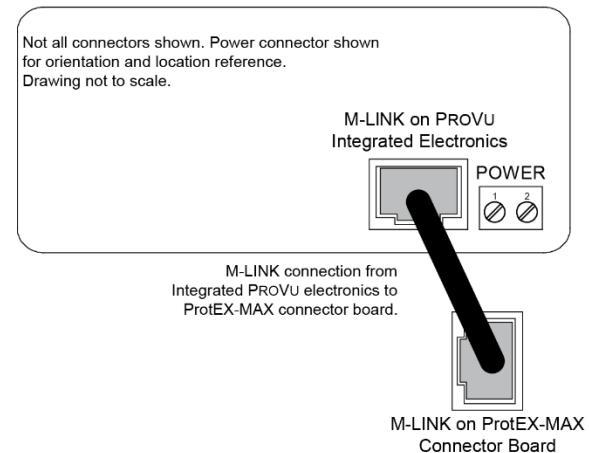
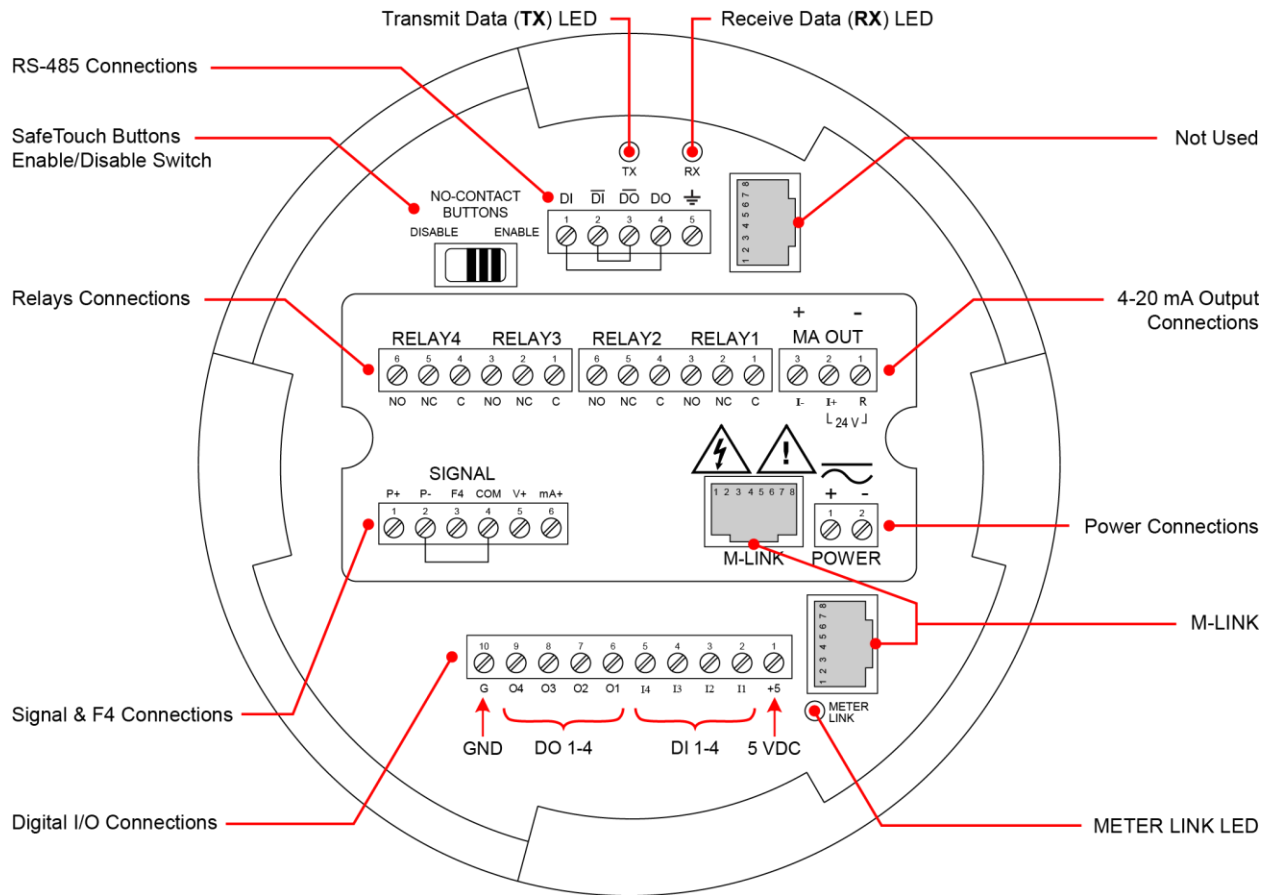

Figure 4. Integrated ProVu Required Connections

**ProVu Electronics Module Layout for PD8-6000-6H7 and PD8-6000-7H7\***



\* For models PD8-6000-6H0 and PD8-6000-7H0 the upper set of connectors (RELAYs & MA OUT) are not present

**Figure 5. ProVu Electronics Module Layout**

**USB Connection**

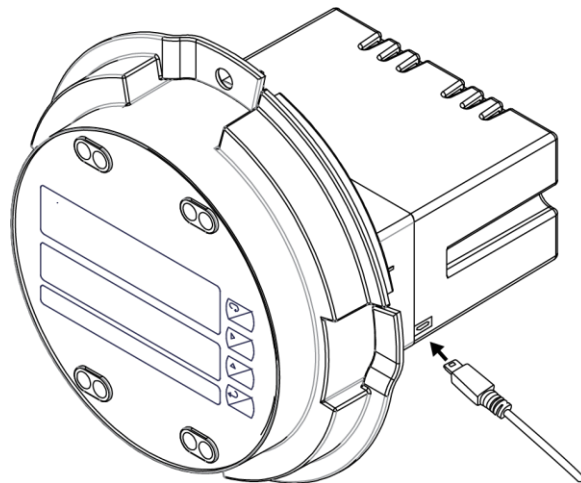

**Figure 6. USB Connection**

**⚠ WARNINGS**

- **DO NOT** disconnect the RJ45 M LINK connector cable. Otherwise the instrument will not function properly.
- The meter should only be connected to a computer while it is located in a safe area.

### Power Connections

Power connections are made to a two-terminal connector labeled POWER. The meter will operate regardless of DC polarity connection. The + and - symbols are only a suggested wiring convention. There are separate models for low voltage and high voltage power. See *Ordering Information* on page 7 for details.

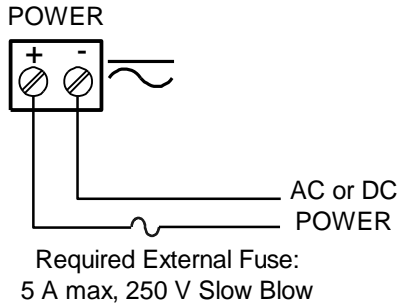

Figure 7. Power Connections

### Signal Connections

Signal connections are made to a six-terminal connector labeled SIGNAL. The COM (common) terminal is the return for the 4-20 mA and the ±10 V input signals.

### Current (mA) Connections

The following figures show examples of current connections.

There are no switches or jumpers to set up for current inputs. Setup and programming is performed through the programming buttons or MeterView Pro software.

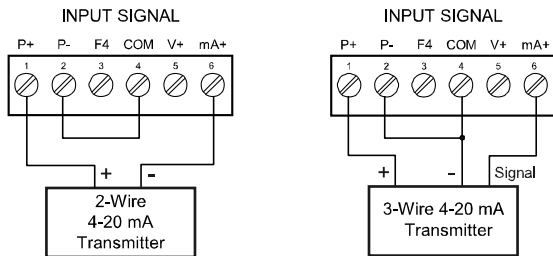

Figure 8. Transmitter Powered by Internal Supply

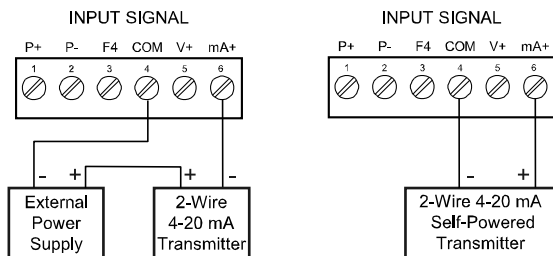

Figure 9. Transmitter Powered by External Supply or Self-Powered

The current input is protected against current overload by an internal resettable fuse. The display may or may not show a fault condition depending on the nature of the overload.

The fuse limits the current to a safe level when it detects a fault condition, and automatically resets itself when the fault condition is removed.

### Voltage (V) Connections

The following figures show examples of voltage connections.

There are no switches or jumpers to set up for voltage inputs. Setup and programming is performed through the programming buttons or MeterView Pro software.

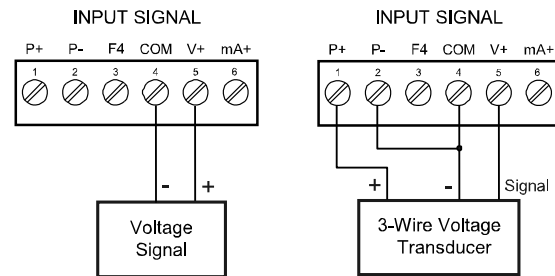

Figure 10. Voltage Input Connections

The meter is capable of accepting any voltage from -10 VDC to +10 VDC.

### Relay Connections

Relay connections are made to two six-terminal connectors labeled RELAY1 – RELAY4. Each relay's C terminal is common only to the normally open (NO) and normally closed (NC) contacts of the corresponding relay. The relays' C terminals should not be confused with the COM (common) terminal of the INPUT SIGNAL connector.

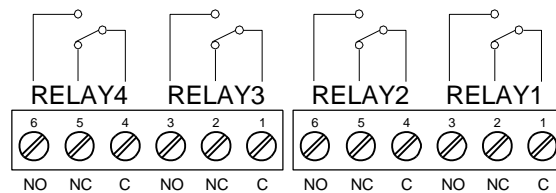
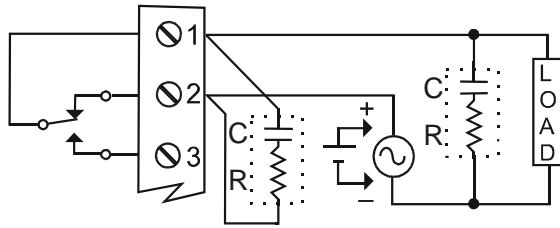

Figure 11. Relay Connections

### Switching Inductive Loads

The use of snubbers to suppress electrical noise is strongly recommended when switching inductive loads to prevent disrupting the microprocessor's operation. The snubbers also prolong the life of the relay contacts. Suppression can be obtained with resistor-capacitor (RC) networks assembled by the user or purchased as complete assemblies. Refer to the following circuits for RC network assembly and installation:



**Figure 12. AC and DC Loads Protection**

Choose R and C as follows:

R: 0.5 to 1 Ω for each volt across the contacts

C: 0.5 to 1 μF for each amp through closed contacts

**Notes:**

1. Use capacitors rated for 250 VAC.
2. RC networks may affect load release time of solenoid loads. Check to confirm proper operation.
3. Install the RC network at the meter's relay screw terminals. An RC network may also be installed across the load. Experiment for best results.

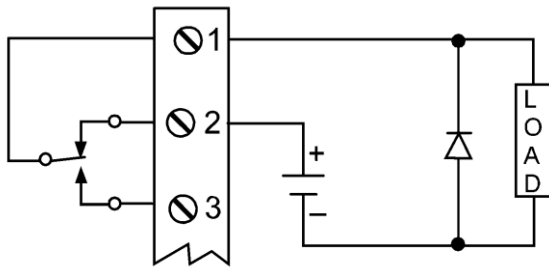

Use a diode with a reverse breakdown voltage two to three times the circuit voltage and forward current at least as large as the load current.

**Figure 13. Low Voltage DC Loads Protection**

### RC Networks (Snubbers) Available from Precision Digital

RC networks are available from Precision Digital and should be applied to each relay contact switching an inductive load. Part number: [PDX6901](#).

**Note:** Relays are de-rated to 1/14th HP (50 watts) with an inductive load.

### RS-485 Connections



The RS-485 connections are made to a five terminal connector used for Modbus® RTU serial communications. The RS-485 terminals include Transmit Data (DO) and (/DO), Receive Data (DI) and (/DI), and Signal Ground. See *Modbus® RTU Serial Communications (5E r iRL)* on page 51 for more information.

There are three diagnostic LEDs: METER LINK, Transmit Data (TX), and Receive Data (RX) to show when the meter is transmitting and receiving data from other devices.

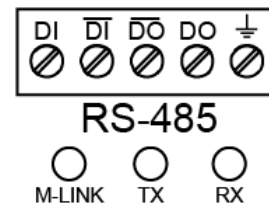

**Figure 14. RS-485 Connections**

### RS-485 Multi-Drop Connection

When using more than one meter in a multi-drop mode, each meter must be provided with its own unique address. The meter address (Slave ID) can be programmed between 1 and 247. The transmit delay can be set between 0 and 199 ms. The parity can be set to even, odd, or none with 1 or 2 stop bits.

**To change the meter address:**

1. Press and hold the Menu button for three seconds to access Advanced Features menu of the meter.
2. Press Up arrow until Serial (5E r iRL) menu is displayed and press Enter, Addr E5 is displayed.
3. Press Enter to change meter address using Right and Up arrow buttons. Press Enter to accept.
4. Press Menu button to exit and return to Run Mode.

### Three-Wire Connections

In order to wire the five pins for use as a three-wire half-duplex RS-485 connection, it is necessary to create a jumper connection between DI to DO and /DI to /DO- as shown below.

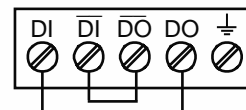

**Figure 15. Three-Wire RS-485 Connections**

### Digital I/O Connections

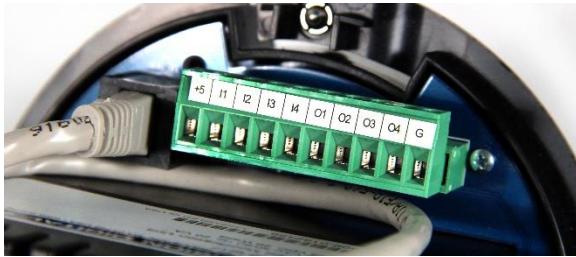

The ProtEX-MAX has a 10-position terminal block for connecting digital inputs and outputs.

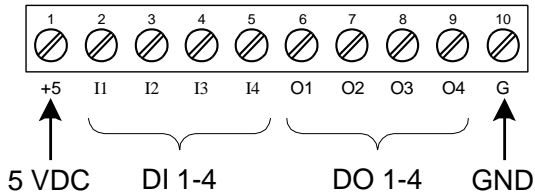

Figure 16. Digital Input and Output Connections

#### IMPORTANT

The onboard digital inputs (1-4) are configured at the factory to function identically to the front panel pushbuttons (Menu, F1, F2, & F3) in order to work with the SafeTouch buttons. Changing the programming of the digital inputs will affect the function of the SafeTouch buttons.

If you wish to change the behavior of the digital inputs, re-assign F1-F3 to the desired function, then change the corresponding digital input to match.

#### WARNING

- **DO NOT** disconnect the RJ45 M LINK connector cable. Otherwise the instrument will not function properly.

### F4 Digital Input Connections

A digital input, F4, is standard on the meter. This digital input should be connected with a normally open contact across F4 and COM, or with an active low signal applied to F4. It can be used for remote operation of front-panel buttons, to acknowledge/reset relays, or to reset max/min values. See *Function Keys & Digital I/O Available Settings* on page 54 for a complete list of capabilities.

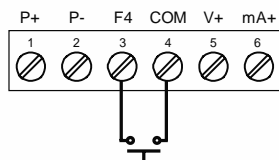

Figure 17. F4 Digital Input Connections

### 4-20 mA Output Connections

Connections for the 4-20 mA transmitter output are made to the connector terminals labeled mA OUT. The 4-20 mA output may be powered internally or from an external power supply.

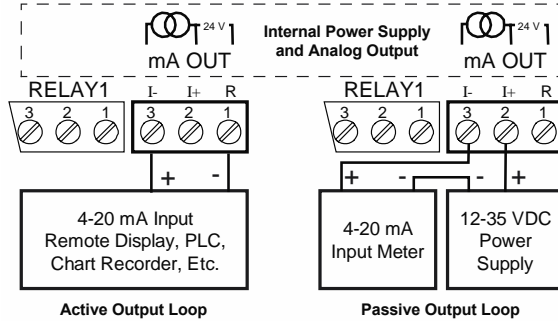

Figure 18. 4-20 mA Output Connections

### Analog Output Power Supply

The internal 24 VDC power supply powering the analog output may be used to power other devices, if the analog output is not used. The I+ terminal is the +24 V and the R terminal is the return.

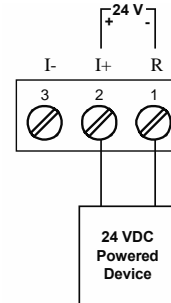

Figure 19. Analog Output Supply Powering Other Devices

### Remote Programming

The meter can be operated via the programming buttons or a remote control station with required approvals to be located in a hazardous area using the digital inputs and outputs.

### Interlock Relay Feature

As the name implies, the interlock relay feature reassigns one, or more, alarm/control relays for use as interlock relay(s). Interlock contact(s) are wired to digital input(s) and activate the interlock relay. This feature is enabled by configuring the relay, and the corresponding digital input(s), see *Setting Up the Interlock Relay (Force On) Feature* on page 47.

In the example below, an Interlock Contact switch is connected to a digital input, which will be used to force on (energize) the Interlock Relay. The Interlock Relay and the Control Relay are connected in series with the load.

- When the Interlock Contact is closed (safe), the Interlock Relay energizes, allowing power to flow to the Control Relay; the corresponding front panel LED is on.
- When the Interlock Contact is open, the corresponding front panel LED flashes (locked out), the Interlock Relay is de-energized, preventing power from flowing to the Control Relay and the load.

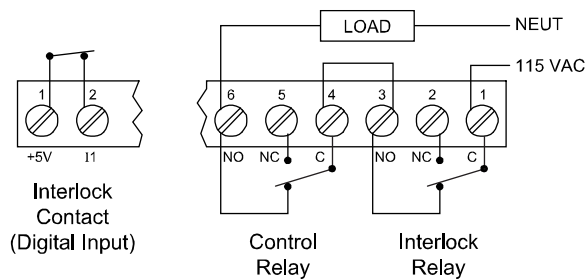

Figure 20. Interlock Connections

## Setup and Programming

There is **no need to recalibrate** the meter when first received from the factory. The meter is **factory calibrated** prior to shipment for milliamps and volts with calibration equipment that is certified to NIST standards.

### Overview





There are no jumpers to set for the meter input selection. Setup and programming is done using MeterView Pro or through the programming buttons. After power and input signal connections have been completed and verified, apply power to the meter.

### LED Status Indicators



LED	State	Indication
1-4	Steady	Alarm condition based on set and reset points, independent of relay status in certain configurations. (Available on all meter configurations, including those without relays installed)
1-4	Flashing	Relay interlock switch open
1-4 & M	Flashing	Relay in manual control mode
T	Flashing	Meter in Tare mode
M	Flashing	Analog output in manual control mode

## Programming Buttons

Button Symbol	Description
	Press to enter or exit Programming Mode, view settings, or exit max/min readings
	Press to reset max/min readings or other parameter/function assigned through the <i>User</i> menu
	Press to display max/min readings or other parameter/function assigned through the <i>User</i> menu
	Press to acknowledge relays or other parameters/function assigned through the <i>User</i> menu

- Press the Menu button to enter or exit the Programming Mode at any time.
- Press the Right arrow button to move to the next digit during digit or decimal point programming.
- Press or hold the Up arrow button to scroll through the menus, decimal point, or to increment the value of a digit.
- Press the Enter button to access a menu or to accept a setting.
- Press and hold the Menu button for three seconds to access the advanced features of the meter.

## SafeTouch Buttons

The ProtEX-MAX is equipped with four sensors that operate as through-glass buttons so that it can be programmed and operated without removing the cover (and exposing the electronics) in a hazardous area.

These buttons can be disabled for security by selecting DISABLE on the switch labeled NO-CONTACT BUTTONS located on the connector board.

To actuate a button, press one finger to the glass directly over the marked button area. Then retract finger more than three inches from the glass before pressing the next button. When the cover is removed, the four mechanical buttons located next to the sensors are used. The sensors are disabled when a mechanical button is pressed and will automatically be re-enabled after 60 seconds of inactivity.

The SafeTouch Buttons are designed to filter normal levels of ambient interference and to protect against false triggering, however, it is recommended that the SafeTouch Buttons be disabled (slide switch to DISABLE) if there is an infrared interference source in line-of-sight to the display.

The SafeTouch Buttons are configured by default to duplicate the function of the front panel mechanical pushbuttons associated with the integrated meter. The symbols by each SafeTouch button correspond to a mechanical button as shown in the above table.

### SafeTouch Button Tips:

- To the extent possible, install the display facing away from sunlight, windows, reflective objects and any sources of infrared interference.
- Keep the glass window clean.
- Tighten the cover securely.
- Use a password to prevent tampering.



## Display Functions & Messages

The meter displays various functions and messages during setup, programming, and operation. The following table shows the main menu functions and messages in the order they appear in the menu.

Display Functions & Messages		
Display	Parameter	Action/Setting Description
SEtUP	Setup	Enter Setup menu
Input	Input	Enter Input selection menu
mA	4-20 mA	Set meter for 4-20 mA input
volt	0-10 VDC	Set meter for ±10 VDC input
d-SCALE	Dual-scale	Press Enter to select dual-scale display for some level applications (Select Yes or No)
units	Units	Select the display units/tags
dec Pt	Decimal point	Set decimal point
PV 1	PV1	PV1 decimal point (Level)
PV 2	PV2	PV2 decimal point (Level)
Prog	Program	Enter the Program menu
SCALE	Scale	Enter the Scale menu
SCALE 1	Scale 1	Enter the Scale menu for PV1
SCALE 2	Scale 2	Enter the Scale menu for PV2
CAL	Calibrate	Enter the Calibration menu
inp 1	Input 1	Calibrate input 1 signal or program input 1 value
dis 1	Display 1	Program display 1 value
inp 2	Input 2	Calibrate input 2 signal or program input 2 value (up to 32 points)
dis 2	Display 2	Program display 2 value (up to 32 points)
Error	Error	Error, calibration not successful, check signal or programmed value
display	Display	Enter the Display menu
line 1	Display Line 1	Press Enter to assign the Main display parameter (default: PV)
line 2	Display Line 2	Press Enter to assign the small display parameter (default: engineering units)
d-intensity	Display intensity	Set display intensity level from 1 to 8
RELAY	Relay	Enter the Relay menu
REL 1	Relay 1	Relay 1 setup

Display Functions & Messages		
Display	Parameter	Action/Setting Description
Rel 1	Action 1	Set relay 1 action
Rel auto	Automatic	Set relay for automatic reset
Rel auto-manual	Auto-manual	Set relay for automatic & manual reset any time
REL Latching	Latching	Set relay for latching operation
REL Latching-cleared	Latching-cleared	Set relay for latching operation with manual reset only after alarm condition has cleared
REL Alternate	Alternate	Set relay for pump alternation control
REL Sampling	Sampling	Set relay for sampling operation
OFF	Off	Disable relay and front panel status LED (Select Off to enable Interlock feature)
Set 1	Set 1	Program set point 1
Reset 1	Reset 1	Program reset point 1
REL 2	Relay 2	Relays 2-4 setup
REL Fail-safe	Fail-safe	Enter Fail-safe menu
REL 1 Fail-safe 1	Fail-safe 1	Set relay 1 fail-safe operation
on	On	Enable fail-safe operation
off	Off	Disable fail-safe operation
REL 2 Fail-safe 2	Fail-safe 2	Set relays 2-4 fail-safe operation
REL Delay	Delay	Enter relay Time Delay menu
REL 1 Delay 1	Delay 1	Enter relay 1 time delay setup
on 1	On 1	Set relay 1 On time delay
off 1	Off 1	Set relay 1 Off time delay
REL 2 Delay 2	Delay 2	Enter relays 2-4 time delay setup
REL Loop break	Loop break	Set relay condition if loop break detected
REL Ignore	Ignore	Ignore loop break condition (Processed as a low signal condition)
on	On	Relay goes to alarm condition when loop break is detected
off	Off	Relay goes to non-alarm condition when loop break is detected
REL Analog output	Analog output	Enter the Analog output scaling menu
dis 1	Display 1	Program display 1 value

Display Functions & Messages		
Display	Parameter	Action/Setting Description
0ut 1	Output 1	Program output 1 value (e.g. 4.000 mA)
d s 2	Display 2	Program display 2 value
0ut 2	Output 2	Program output 2 value (e.g. 20.000 mA)
rESEt	Reset	Press Enter to access the Reset menu
rSt H i	Reset high	Press Enter to reset max display
rSt Lo	Reset low	Press Enter to reset min display
rSt HL	Reset high & low	Press Enter to reset max & min displays
rSt tr	Reset tare	Reset tare
Control	Control	Enter Manual Control menu
Auto	Automatic	Press Enter to set meter for automatic operation
MAN	Manual	Press Enter to manually control relays or analog output operation
PRSS	Password	Enter the Password menu
PRSS 1	Password 1	Set or enter Password 1
PRSS 2	Password 2	Set or enter Password 2
PRSS 3	Password 3	Set or enter Password 3
unLoc	Unlocked	Program password to lock meter
Locd	Locked	Enter password to unlock meter
999999 -99999	Flashing	Over/under range condition

## Main Menu

The main menu consists of the most commonly used functions: *Setup*, *Reset*, *Control*, and *Password*.

- Press Menu button to enter Programming Mode then press the Up arrow button to scroll main menu.
- Press Menu, at any time, to exit and return to Run Mode. Changes made to settings prior to pressing Enter are not saved.
- Changes to the settings are saved to memory only after pressing Enter/F3.
- The display moves to the next menu every time a setting is accepted by pressing Enter/F3.

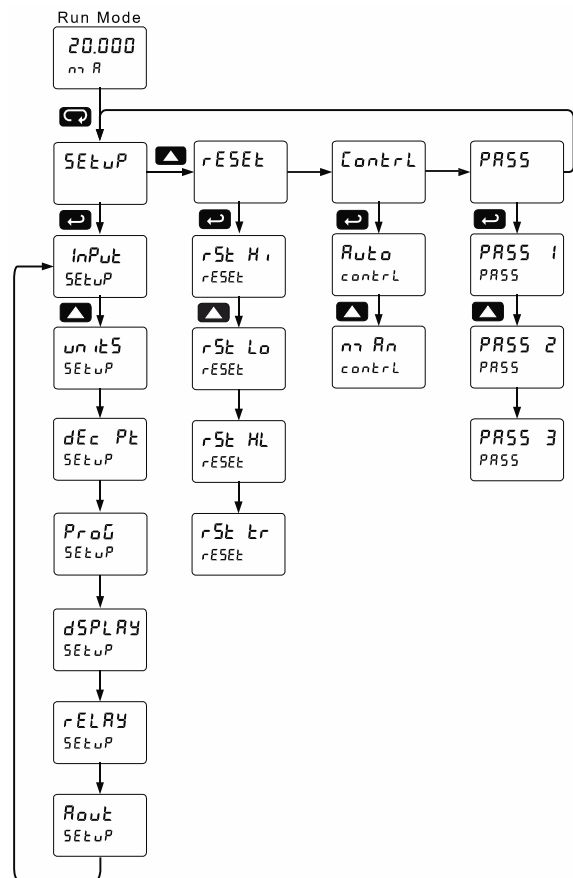

### Setting Numeric Values

The numeric values are set using the Right and Up arrow buttons. Press Right arrow to select next digit and Up arrow to increment digit value. The digit being changed is displayed brighter than the rest. Press and hold Up to auto-increment the display value. If negative numbers are allowed, the first digit position will include a negative symbol (-) after the 9. Press the Enter button, at any time, to accept a setting or Menu button to exit without saving changes.

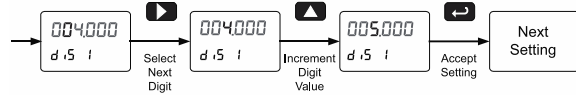

### Setting Up the Meter (SEtUP)

The Setup menu is used to select:

1. Input signal the meter will accept
2. Dual-scale feature for some level applications
3. Select the display units/tags
4. Decimal point position
5. Programming Menu
6. Display parameter and intensity
7. Relay operation
8. 4-20 mA analog output scaling

Press the Enter button to access any menu or press Up arrow button to scroll through choices. Press the Menu button to exit at any time.

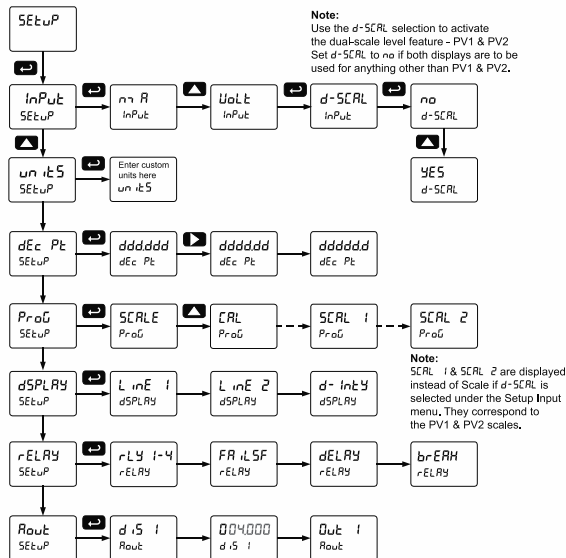

### Setting the Input Signal (InPUt)

Enter the Input menu to set up the meter to display current (mA) or voltage (VOLT) inputs.

The current input is capable of accepting any signal from 0 to 20 mA. Select current input to accept 0-20 mA or 4-20 mA signals.

The voltage input is capable of accepting any signal from -10 to +10 VDC. Select voltage input to accept 0-5, 1-5, 0-10, or ±10 VDC signals.

After selecting mA or Volt input, d-SCAL is displayed; press Enter to select "Yes" or "No". Selecting "Yes" enables the dual-scale feature, which allows for the Scale (SCALE) and Units (uNITS) menus to be used to scale the same input in two different scales for PV1 & PV2.

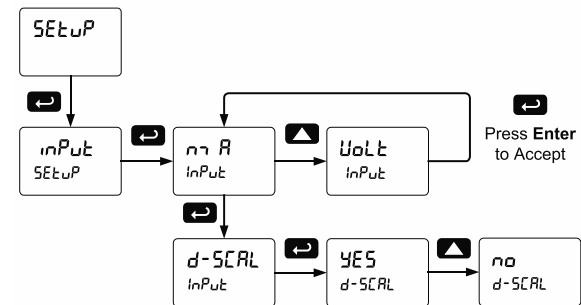

Set d-SCAL to no if only one scale is needed for the input.

### Setting the Display Units or Custom Tags (uN t5)

Enter the display unit or custom tag that will be displayed if d uN t5 is selected as the line 2 parameter. See the *Setting the Display Parameter & Intensity (d5PLRY)* flow chart on page 39 to access the display menu to show the unit or tag on display line 2. The engineering units or custom legends can be set using the following 7-segment character set:

Display	Character	Display	Character
0	0	K	K
1	1	L	L
2	2	m	m
3	3	n	n
4	4	O	O
5	5	o	o
6	6	P	P
7	7	q	q
8	8	r	r
9	9	S	S
A	A	t	t
b	b	u	u
C	C	v	v
c	c	w	w
d	d	X	X
E	E	Y	Y
F	F	Z	Z
G	G	.	.
g	g	/	/
H	H	[	[
h	h	]	]
i	i	=	=
j	j	°	Degree(<)
J	J		Space

**Notes:**

1. Degree symbol represented by (<) if programming with MeterView Pro.
2. The letters "m" and "w" use two 7-segment LEDs each; when selected the characters to the right are shifted one position.
3. Press and hold up arrow to auto-scroll the characters in the display.

### Setting the Decimal Point (dEc Pt)

The decimal point may be set with up to five decimal places or with no decimal point at all.

The decimal point selection should be made prior to scaling, calibrating or programming the meter.

Pressing the Right arrow moves the decimal point one place to the right until no decimal point is displayed, and then it moves to the leftmost position. Pressing the Up arrow moves the decimal point one place to the left.

If the dual-scale level feature is selected, the decimal point selections for PV1 & PV2 are enabled.

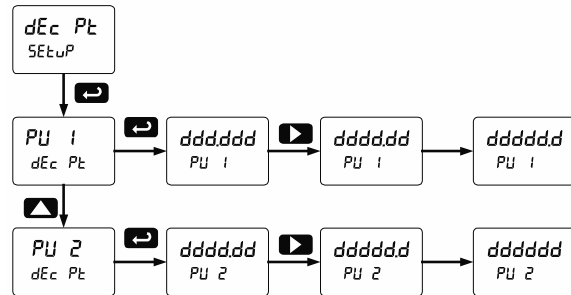

### Programming the Meter (Prog)

The meter may either be scaled (SCALE) without applying an input or calibrated (CAL) by applying an input. The meter comes factory calibrated to NIST standards, so for initial setup, it is recommended to use the (SCALE) function.

The Program menu contains the Scale (SCALE) and the Calibrate (CAL) menus.

Process inputs may be scaled or calibrated to any display within the range of the meter.

The PD8-6000 is a single input meter with dual-scale capability.

If the dual-scale level feature is selected in the Setup menu, the Scale 1 and Scale 2 menus are enabled for PV1 & PV2 respectively.

The process input may be calibrated or scaled to any display value within the range of the meter.

**Note:** The Scale and Calibrate functions are exclusive of each other. The meter uses the last function programmed. Only one of these methods can be employed at a time. The Scale and Calibrate functions can use up to 32 points (default is 2). The number of points should be set in the Advanced menu prior to scaling and calibration of the meter. See *Multi-Point Linearization (LINEAR)* menu on page 52 for details.

#### Program Menu for Single Scale Process

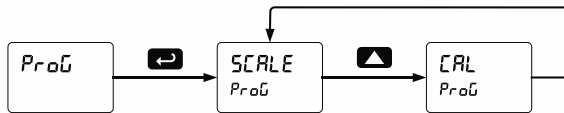

#### Program Menu for Dual-Scale Level Applications

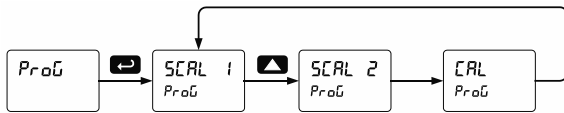

Additional parameters, not needed for most applications, are programmed in the *Advanced Features* menu. See *Advanced Features Menu* on page 50.

#### Multi-Point Calibration & Scaling

The meter is set up at the factory for 2-point linear calibration. The number of points for multi-point calibration/scaling is set up in the *Advanced Features* menu. Up to 32 linearization points may be selected for PV1 and up to 8 linearization points may be selected for PV2. See *Multi-Point Linearization (LINEAR)* menu on page 52 for details.

#### IMPORTANT

- **Reverse Scaling**  
The meter can be scaled so that 4 mA represents the high end of the process value range being measured by the transmitter and 20 mA represents the low end of the process value range.

### Scaling the Meter (SCALE)

The process input (4-20 mA, ±10 VDC) can be scaled to display the process variable in engineering units.

A signal source is not needed to scale the meter; simply program the inputs and corresponding display values.

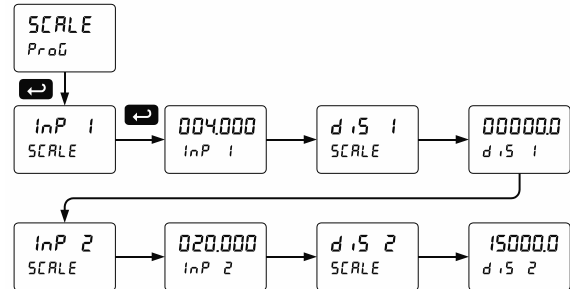

### Dual-Scale for Level Applications

The analog input can be displayed in two different scales, by enabling the dual-scale feature (d-SCALE) in the *Setup - Input* menu. See *Setting the Input Signal (Input)* on page 35.

To enable the dual-scale feature for some level applications you must select d-SCALE in the Input selection menu.

#### Scaling the Input for PV1 (SCALE 1)

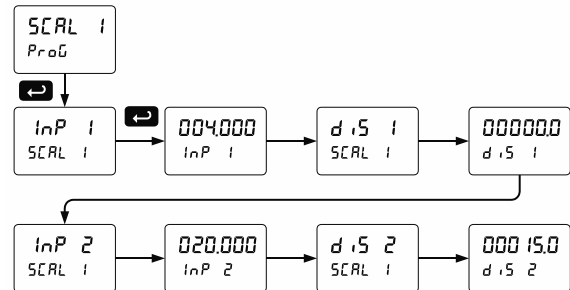

#### Scaling the Input for PV2 (SCALE 2)

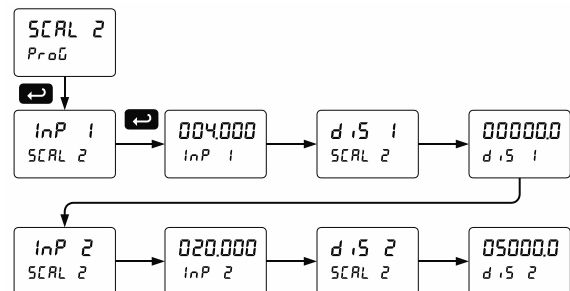

### Error Message (Error)

An error message indicates that the calibration or scaling process was not successful. After the error message is displayed, the meter reverts to the input prior to the failure during calibration or scaling and to input 1 during internal calibration, allowing the appropriate input signal to be applied or programmed. The error message might be caused by any of the following conditions:

1. Input signal is not connected to the proper terminals or it is connected backwards\*.
2. Wrong signal selection in Setup menu\*.
3. Minimum input span requirements not maintained.
4. Input 1 signal inadvertently applied to calibrate input 2\*.

\*Not relevant when scaling the meter.

For instructions on how to program numeric values see *Setting Numeric Values*, page 34.

### Minimum Input Span

The minimum input span is the minimum difference between input 1 and input 2 signals required to complete the calibration or scaling of the meter.

Input Range	Input 1 & Input 2 Span
4-20 mA	0.15 mA
±10 VDC	0.10 VDC

### Calibrating the Meter with External Source (CAL)

*Note: To scale the meter without a signal source refer to *Scaling the Meter (SCALE)* on page 37.*

The meter can be calibrated to display the process variable in engineering units by applying the appropriate input signal and following the calibration procedure.

The use of a calibrated signal source is strongly recommended to calibrate the meter.

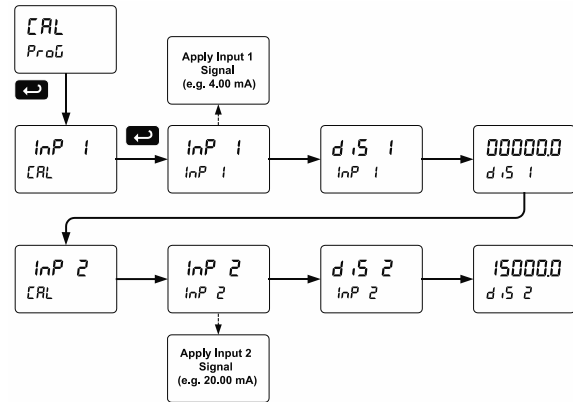

**Note:** Inputs for the above example are:  
 Input 1: 4.00 mA; Display 1: 0.0 Gallons  
 Input 2: 20.00 mA; Display 2: 15000.0 Gallons

Warm up the meter for at least 15 minutes before performing calibration to ensure specified accuracy.

### Setting the Display Parameter & Intensity (dSPLeRY)

The main display (LINE 1) can be programmed to display:

1. Process value 1 (PV1)
2. Process value 2 (PV2)\*
3. Percent of PV1 (PCT)\*
4. Relay set points
5. Max & min values
6. Modbus® input
7. Display reading and units
8. Display gross
9. Toggle net & gross

The second display (LINE 2) can be programmed to display:

1. Unit
2. Process value 1 (PV1)
3. Process value 2 (PV2)\*
4. Percent of PV1 (PCT)\*
5. Relay set points
6. Max & min values
7. Engineering units or custom legends
8. Modbus® input
9. Off (no display)
10. Toggle reading and units
11. Display gross
12. Toggle net/gross

\*These menu items will only appear if Dual-Scale feature is turned on.

After setting up the input and display, press the Menu button to exit programming and skip the rest of the setup menu.

### Display Intensity (d-IntY)

The meter has eight display intensity levels to give the best performance under various lighting conditions. Select intensity 8 for outdoor applications. The default intensity is 6.

### Display Parameter Menu

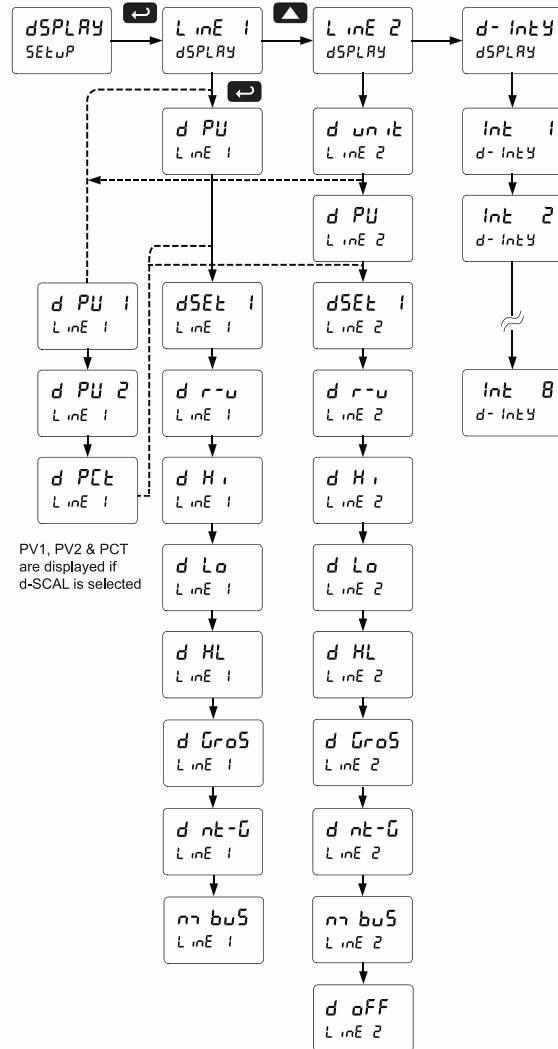

### Dual-Scale Display Feature

The dual-scale feature is of particular value in level applications where a second scaled display can represent the measured input in a different form (i.e. gallons & height). Both displays are independently scaled and are based on the 4-20 mA input signal.



Gallons & mA



Gallons & Height

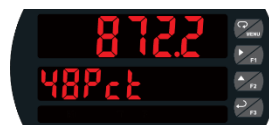

Gallons & Percent



Gallons & Head PSI

## Setting the Relay Operation (rELAY)

This menu is used to set up the operation of the relays.

**CAUTION**

- During setup, the relays do not follow the input and they will remain in the state found prior to entering the Relay menu.

1. Relay action
  - a. Automatic reset only (non-latching)
  - b. Automatic + manual reset at any time (non-latching)
  - c. Latching (manual reset only)
  - d. Latching with Clear (manual reset only after alarm condition has cleared)
  - e. Pump alternation control (automatic reset only)
  - f. Sampling (the relay is activated for a user-specified time)
  - g. Off (relay state controlled by Interlock feature)
2. Set point
3. Reset point
4. Fail-safe operation
  - a. On (enabled)
  - b. Off (disabled)
5. Time delay
  - a. On delay (0-999.9 seconds)
  - b. Off delay (0-999.9 seconds)
6. Relay action for loss (break) of 4-20 mA input (ignore, on, off)

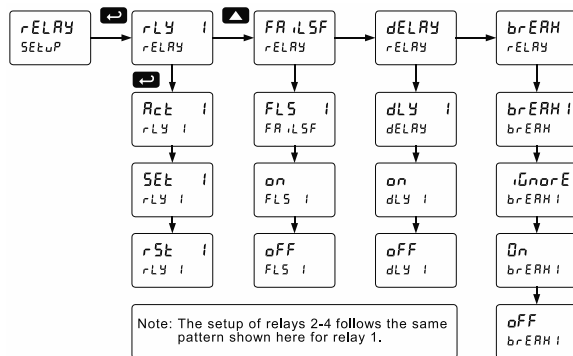

## Setting the Relay Action

Operation of the relays is programmed in the *Action* menu. The relays may be set up for any of the following modes of operation:

1. Automatic reset (non-latching)
2. Automatic + manual reset at any time (non-latching)
3. Latching (manual reset only, at any time)
4. Latching with Clear (manual reset only after alarm condition has cleared)
5. Pump alternation control (automatic reset only)
6. Sampling (the relay is activated for a user-specified time)
7. Off (relay state controlled by Interlock feature)

The following graphic shows relay 1 action setup; relay 2-4 are set up in a similar fashion.

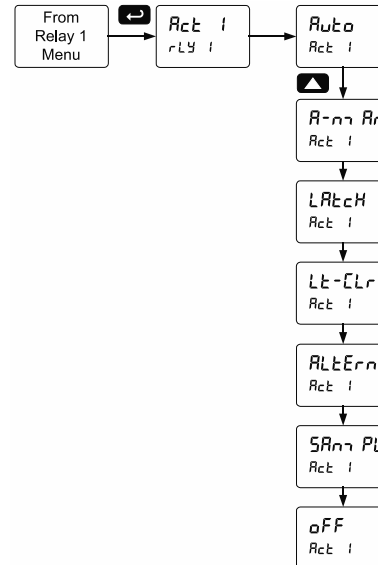

### Programming Set and Reset Points

High alarm indication: program set point above reset point.

Low alarm indication: program set point below reset point.

The deadband is determined by the difference between set and reset points. Minimum deadband is one display count. If the set and reset points are programmed with the same value, the relay will reset one count below the set point.

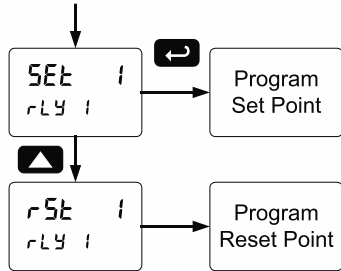

**Note:** Changes are not saved until the reset point has been accepted.

### Setting Fail-Safe Operation

In fail-safe mode of operation, the relay coil is energized when the process variable is within safe limits and the relay coil is de-energized when the alarm condition exists. The fail-safe operation is set independently for each relay. Select **on** to enable or select **off** to disable fail-safe operation.

### Programming Time Delay

The *On* and *Off* time delays may be programmed for each relay between 0 and 999.9 seconds. The relays will transfer only after the condition has been maintained for the corresponding time delay.

The *On* time delay is associated with the set point.

The *Off* time delay is associated with the reset point.

### Relay Action for Loss of 4-20 mA Input (Loop Break)

A loop break condition is triggered when the 4-20 mA input signal drops below 0.005 mA. Each relay may be programmed to go to one of the following conditions when the meter detects the loss of the input signal (i.e. < 0.005 mA):

1. Turn *On* (Go to alarm condition)
2. Turn *Off* (Go to non-alarm condition)
3. Ignore (Processed as a low signal condition)

The following graph shows the loop break relay operation for a high alarm relay.

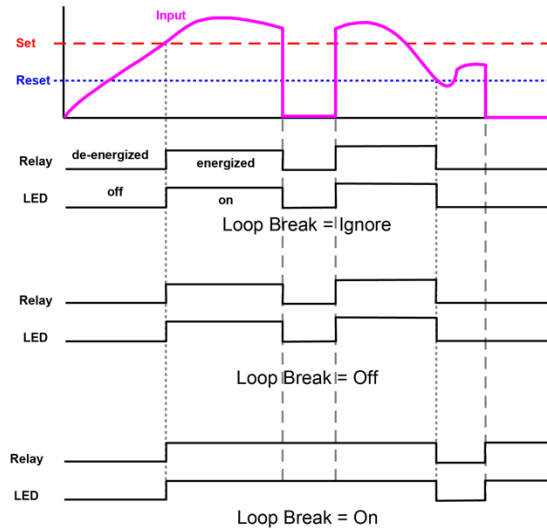

### Relay and Alarm Operation Diagrams

The following graphs illustrate the operation of the relays, status LEDs, and ACK button.

#### High Alarm Operation (Set > Reset)

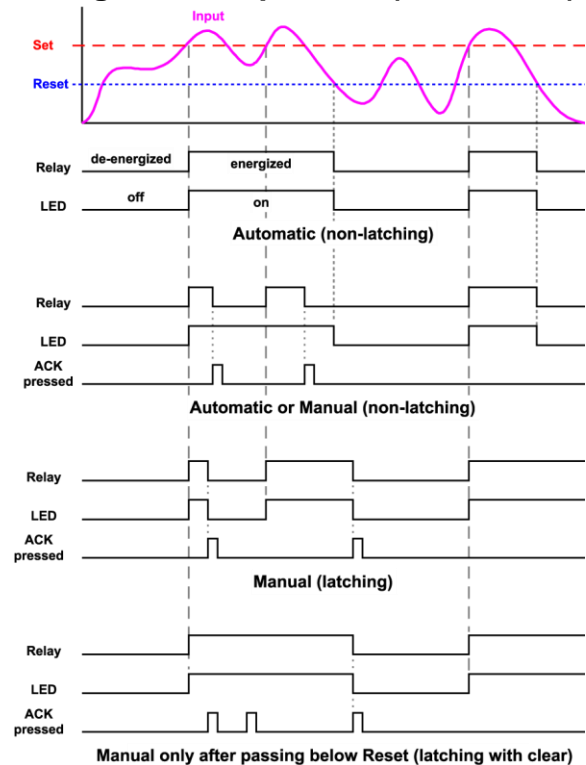

For Manual reset mode, ACK can be pressed anytime to turn "off" relay. To detect a new alarm condition, the signal must go below the set point, and then go above it.

### Low Alarm Operation (Set < Reset)

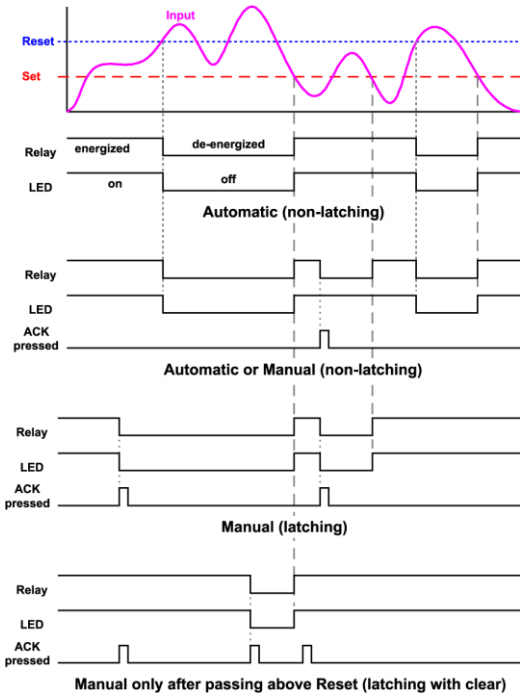

**Note:** For Manual reset mode, ACK can be pressed anytime to turn "off" relay. For relay to turn back "on", signal must go above set point and then go below it.

### High Alarm with Fail-Safe Operation (Set > Reset)

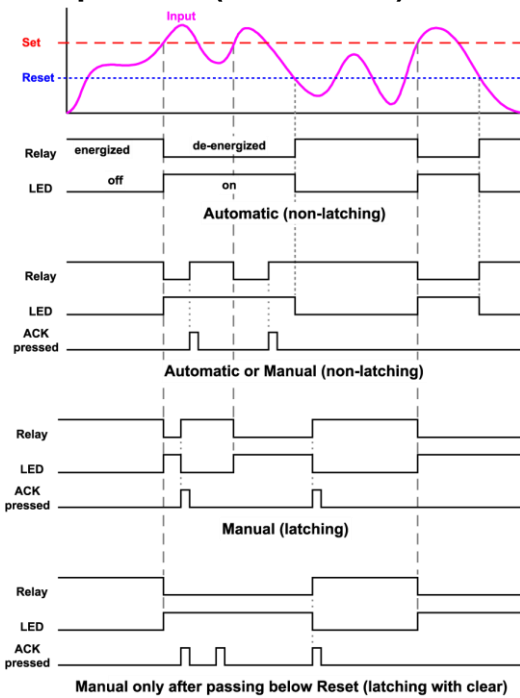

**Note:** Relay coil is energized in non-alarm condition. In case of power failure, relay will go to alarm state.

### Low Alarm with Fail-Safe Operation (Set < Reset)

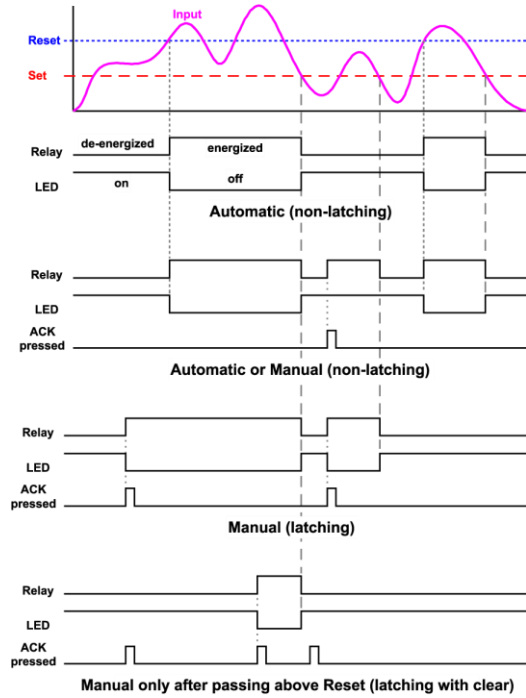

**Note:** Relay coil is energized in non-alarm condition. In case of power failure, relay will go to alarm state.

### Time Delay Operation

The following graphs show the operation of the time delay function.

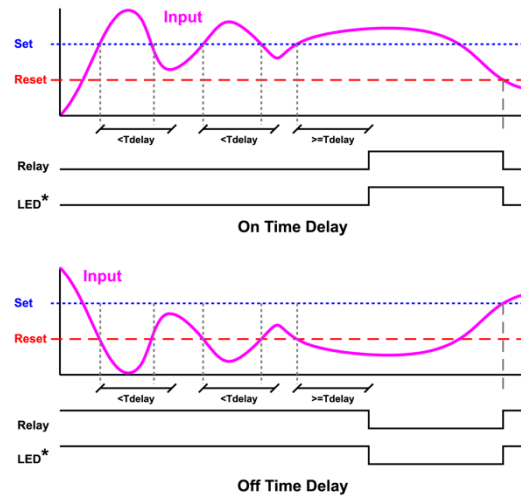

When the signal crosses the set point, the *On* time delay timer starts and the relay trips when the time delay has elapsed. If the signal drops below the set point (high alarm) before the time delay has elapsed, the *On* time delay timer resets and the relay does not change state. The same principle applies to the *Off* time delay.

**Note:** If "Automatic or Manual (R-n → Rn)" reset mode is selected, the LED follows the reset point and not the relay state when the relay is acknowledged.

### Pump Alternation Control Operation

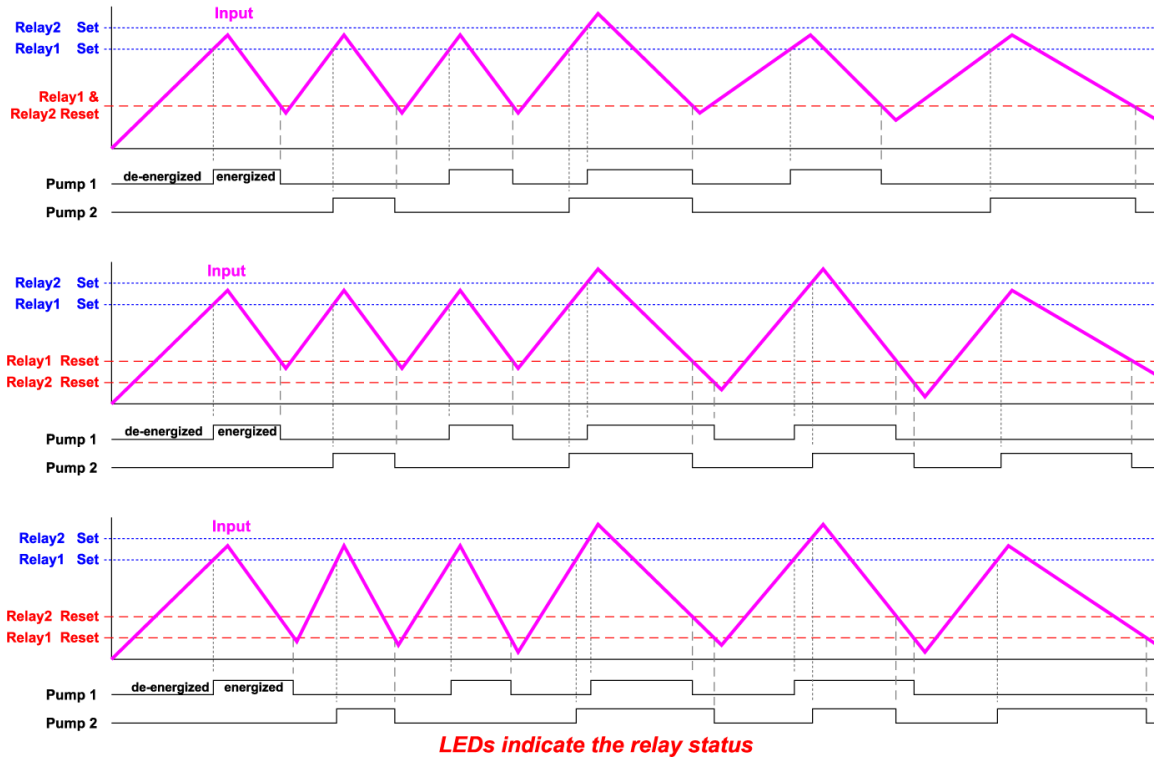

### Relay Sampling Operation

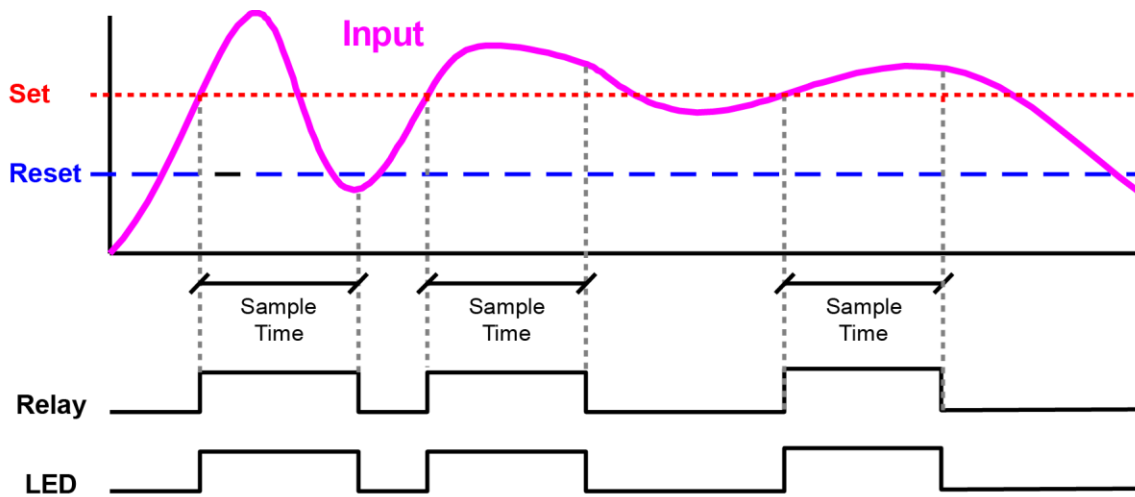

When the signal crosses the set point, the relay trips and the sample time starts. After the sample time has elapsed, the relay resets. The cycle repeats every time the set point is crossed, going up for high alarms and going down for low alarms.

The sample time can be programmed between 0.1 and 5999.9 seconds.

## Relay Operation Details

### Overview

The four-relays option for the meter expands its usefulness beyond simple indication to provide users with alarm and control functions. Typical applications include high and low temperature, level, pressure or flow alarms, control applications such as simple on/off pump control, and pump alternation control for up to 4 pumps. There are four basic ways the relays can be used:

1. High and Low Alarms with Latching or Non-Latching Relays
2. Simple On/Off Control with 100% Adjustable Deadband
3. Sampling (Based on Time)
4. Pump Alternation Control for up to 4 Pumps

### Relays Auto Initialization

When power is applied to the meter, the front panel LEDs and alarm relays will reflect the state of the input to the meter. The following table indicates how the alarm LEDs and relays will react on power-up based on the set and reset points:

Alarm #	HI or LO Alarm	Set Point	Reset Point	Power-Up Reading	Relay & LED
1	HI	1000	500	499	Off
2	LO	700	900	499	On
3	LO	250	400	499	Off
4	HI	450	200	499	On

### Fail-Safe Operation

The following table indicates how the relays behave based on the fail-safe selection for each relay:

Fail-Safe Selection	Non-Alarm State		Alarm State		Power Failure
	NO	NC	NO	NC	
Off	Open	Closed	Closed	Open	Relays go to non-alarm state
On	Closed	Open	Open	Closed	Relays go to alarm state

**Note:** NO = Normally Open, NC = Normally Closed. This refers to the condition of the relay contacts when the power to the meter is off.

## Front Panel LEDs

The alarm status LEDs on the front panel are available on all meters, even those without relays installed, and provide status indication for the following:

LED	Status
1	Alarm 1
2	Alarm 2
3	Alarm 3
4	Alarm 4

The meter is supplied with four alarm points that include front panel LEDs to indicate alarm conditions. This standard feature is particularly useful for alarm applications that require visual-only indication. The LEDs are controlled by the set and reset points programmed by the user. When the display reaches a set point for a high or low alarm, the corresponding alarm LED will turn on. When the display returns to the reset point the LED will go off. The front panel LEDs respond differently for latching and non-latching relays.

For non-latching relays, the LED is always off during normal condition and always on during alarm condition, regardless of the state of the relay (e.g. Relay acknowledged after alarm condition).

For latching relays, the alarm LEDs reflect the status of the relays, regardless of the alarm condition. The following tables illustrate how the alarm LEDs function in relation to the relays and the acknowledge button (Default: F3 key assigned to ACK).

### Latching and Non-Latching Relay Operation

The relays can be set up for latching (manual reset) or non-latching (automatic reset) operation.

Relay terminology for following tables	
Terminology	Relay Condition
On	Alarm (Tripped)
Off	Normal (Reset)
Ack	Acknowledged

The On and Off terminology does not refer to the status of the relay's coil, which depends on the fail-safe mode selected.

### WARNING

- In latching relay mode, if Fail-Safe is off, latched relays will reset (unlatch) when power is cycled.

### Non-Latching Relay (ᐱᐸᐸᐅ)

In this application, the meter is set up for automatic reset (non-latching relay). Acknowledging the alarm while it is still present has no effect on either the LED or the relay. When the alarm finally goes away, the relay automatically resets and the LED also goes off.

Automatic reset only		
Condition	LED	Relay
Normal	Off	Off
Alarm	On	On
Ack (No effect)	On	On
Normal	Off	Off

### Non-Latching Relay with Manual Reset (ᐱᐸᐸᐅᐱᐸᐸᐅ)

In this application, the meter is set up for automatic and manual reset at any time (non-latching relay). The LED and the relay automatically reset when the meter returns to the normal condition.

In addition, the relay can be manually reset while the alarm condition still exists, but the LED will stay on until the meter returns to the normal condition.

Automatic + manual reset at any time		
Condition	LED	Relay
Normal	Off	Off
Alarm	On	On
Normal	Off	Off
Next Alarm	On	On
Ack	On	Off
Normal	Off	Off

### Latching Relay (ᐱᐸᐸᐅᐱᐸᐸᐅ)

In this application, the meter is set up for manual reset at any time. Acknowledging the alarm even if the alarm condition is still present resets the relay and turns off the LED.

Manual reset any time		
Condition	LED	Relay
Normal	Off	Off
Alarm	On	On
Ack	Off	Off

### Latching Relay with Clear (ᐱᐸᐸᐅᐱᐸᐸᐅ)

In this application, the meter is set up for manual reset only after the signal passes the reset point (alarm condition has cleared). Acknowledging the alarm while it is still present has no effect on either the LED or the relay. When the alarm is acknowledged after it returns to the normal state, the LED and the relay go off. Notice that the LED remains on, even after the meter returns to the normal condition. This is because, for latching relays, the alarm LED reflects the status of the relay, regardless of the alarm condition.

Manual reset only after alarm condition has cleared		
Condition	LED	Relay
Normal	Off	Off
Alarm	On	On
Ack (No effect)	On	On
Normal	On	On
Ack	Off	Off

### Acknowledging Relays

There are three ways to acknowledge relays programmed for manual reset:

1. Via the programmable front panel function keys F1-F3 (Example: F3 assigned to ACK).



2. Remotely via a normally open push button wired to the F4 terminal.

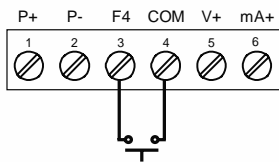

3. Remotely via a normally open push button wired to one of the digital inputs and the +5 V terminal on the digital I/O connections.

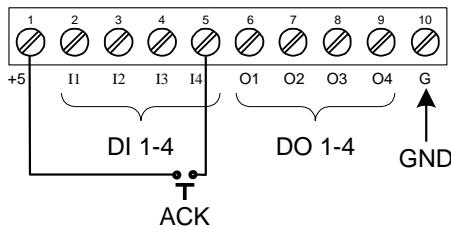

When the ACK button or the assigned digital input is closed, all relays programmed for manual reset are acknowledged.

### Pump Alternation Control Applications (RL&ERn)

For pump control applications where two or more similar pumps are used to control the level of a tank or a well, it is desirable to have all the pumps operate alternately. This prevents excessive wear and overheating of one pump over the lack of use of the other pumps.

Up to 4 relays can be set up to alternate every time an on/off pump cycle is completed. The set points and reset points can be programmed, so that the first pump on is the first pump off.

### Application #1: Pump Alternation Using Relays 1 & 2

1. Relays 1 and 2 are set up for pump alternation.
2. Relays 3 and 4 are set up for low and high alarm indication.

Set and Reset Point Programming			
Relay	Set Point	Reset Point	Function
1	30.000	10.000	Controls pump #1
2	35.000	5.000	Controls pump #2
3	4.000	9.000	Controls low alarm
4	40.000	29.000	Controls high alarm

### Pump Alternation Operation

1. Pump #1 turns on when level reaches 30.000, when level drops below 10.000, pump #1 turns off.
2. The next time level reaches 30.000, pump #2 turns on, when level drops below 10.000, pump #2 turns off.
3. If the level doesn't reach 35.000, pump #1 and pump #2 will be operating alternately.
4. If pump #1 cannot keep the level below 35.000, pump #2 will turn on at 35.000, then as the level drops to 10.000, pump #1 turns off, pump #2 is still running and shuts off below 5.000.
5. Notice that with the set and reset points of pump #2 outside the range of pump #1, the first pump on is the first pump to go off. This is true for up to 4 alternating pumps, if setup accordingly.
6. Relay #3 will go into alarm if the level drops below 4.000 and relay #4 will go into alarm if the level exceeds 40.000.

### Application #2: Pump Alternation Using Relays 3 & 4

1. Relays 1 and 2 are set up for low and high alarm indication.
2. Relays 3 and 4 are set up for pump alternation.

Set and Reset Point Programming			
Relay	Set Point	Reset Point	Function
1	495	750	Controls low alarm
2	7500	6900	Controls high alarm
3	7000	900	Controls backup pump
4	6000	1000	Controls main pump

### Pump Alternation Visual Representation

The following graphics provide a visual representation of a typical pump alternation application with high and low alarm monitoring:

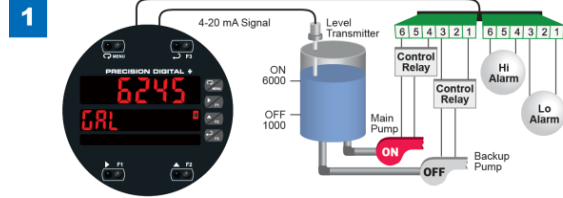

Relay #4 turns the main pump on at 6000 gallons and turns it off at 1000 gallons.

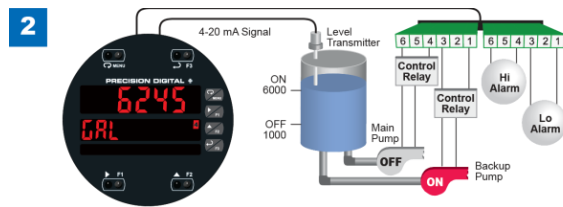

With the Pump Alternation feature activated, the next time the level reaches 6000 gallons, relay #3 transfers and starts the backup pump.

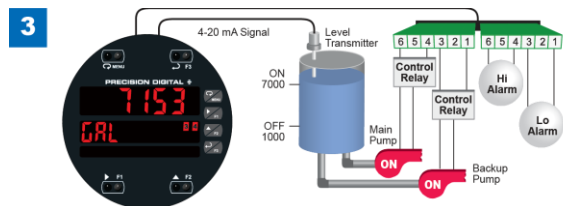

If the backup pump is not able to keep up, and the level reaches 7000 gallons, relay #4 transfers and starts the main pump as well.

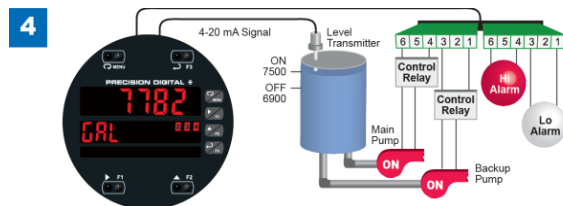

Relay #2 trips the High Level Alarm at 7500 gallons and resets at 6900 gallons.

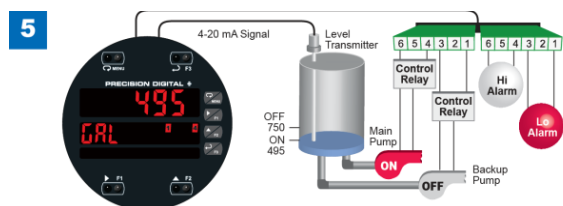

Relay #1 trips the Low Level Alarm at 495 gallons and resets at 750 gallons.

### Setting Up the Interlock Relay (Force On) Feature

Relays 1-4 can be set up as interlock relays. To set up the relays for the interlock feature:

1. Access the *Setup – Relay – Action* menu and set the action to off.

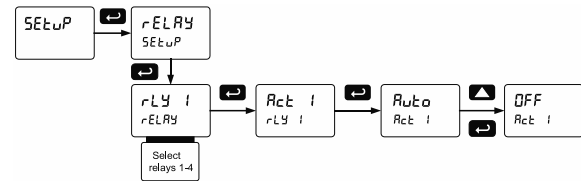

2. In the Advanced features – *User* menu program any of the digital inputs to *Force On* any of the internal relays (1-4).

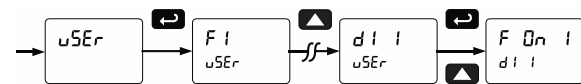

3. Connect a switch or dry contact between the +5V terminal and the corresponding digital input (d1-1 to d1-4) terminal.

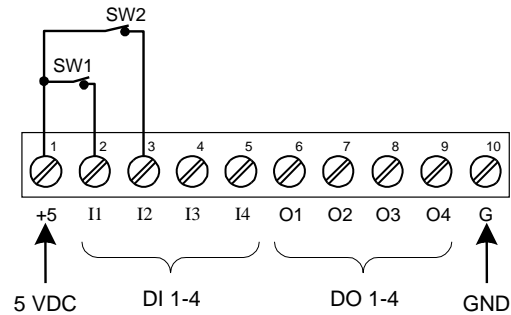

### Interlock Relay Operation Example

Relays 1 & 2 are configured to energize (their front panel LEDs are steady on) when SW1 & SW2 switches (above) are closed. If the contacts to these digital inputs are opened, the corresponding front panel LEDs flash indicating this condition. The processes being controlled by the interlock relay will stop, and will re-start only after the interlock relay is re-activated by the digital inputs (switches).

**Note:** If multiple digital inputs are assigned to the same relay, then the corresponding logic is (AND) – i.e. both switches must be closed to activate the relay.

### IMPORTANT

- If the digital inputs are assigned to the *Interlock Function*, then they cannot be used to program the meter remotely.

## Scaling the 4-20 mA Analog Output (Rout)

The 4-20 mA analog output can be scaled to provide a 4-20 mA signal for any display range selected.

No equipment is needed to scale the analog output; simply program the display values to the corresponding mA output signal.

The *Analog Output* menu is used to program the 4-20 mA output based on display values.

For further details, see *Setting Numeric Values* on page 34, *Analog Output Value for Loss of 4-20 mA Input (Loop Break)* on page 54.

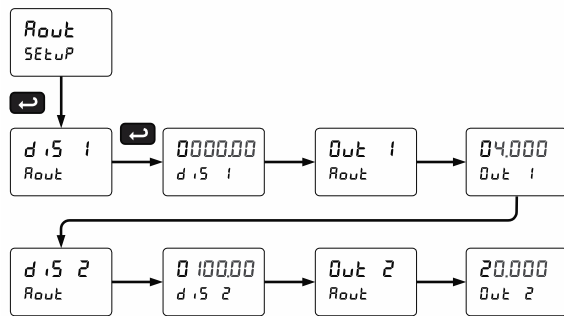

## Reset Menu (rESEt)

The *Reset* menu is used to reset the maximum or minimum reading (peak or valley) reached by the process; both may be reset at the same time by selecting “reset high & low” (rSEt HL). The tare value used to zero the display may be reset by selecting “reset tare” (rSEt tr).

## Manual Control Menu (Control)

The *Manual Control* menu is used to control the 4-20 mA analog output and the relays manually, ignoring the input. Each relay and analog output can be programmed independently for manual control. Selecting automatic control sets all relays and analog output for automatic operation.

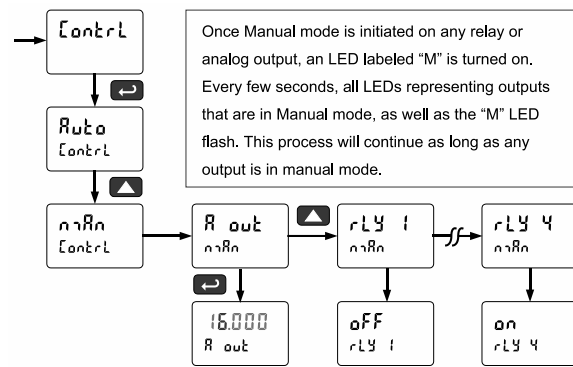

## Setting Up the Password (PR55)

The *Password* menu is used for programming three levels of security to prevent unauthorized changes to the programmed parameter settings.

- Pass 1: Allows use of function keys and digital inputs
- Pass 2: Allows use of function keys, digital inputs and editing set/reset points
- Pass 3: Restricts all programming, function keys, and digital inputs

### Protecting or Locking the Meter

Enter the *Password* menu and program a six-digit password.

For instructions on how to program numeric values see *Setting Numeric Values* on page 35.

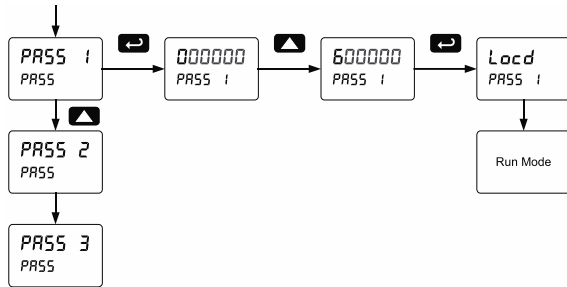

### Making Changes to a Password Protected Meter

If the meter is password protected, the meter will display the message *Locd* (*Locked*) when the Menu button is pressed. Press the Enter button while the message is being displayed and enter the correct password to gain access to the menu. After exiting the programming mode, the meter returns to its password protected condition.

## Disabling Password Protection

To disable the password protection, access the *Password* menu and enter the correct password twice, as shown below. The meter is now unprotected until a new password is entered.

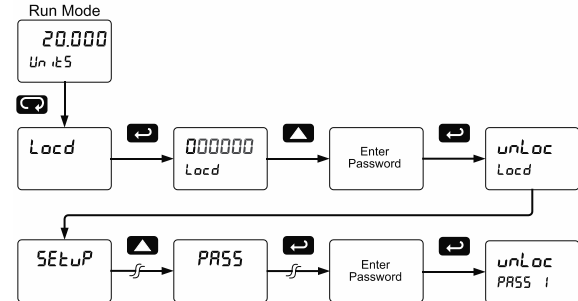

If the correct six-digit password is entered, the meter displays the message *unLoc* (*unlocked*) and the protection is disabled until a new password is programmed.

If the password entered is incorrect, the meter displays the message *Locd* (*Locked*) for about two seconds, and then it returns to Run Mode. To try again, press Enter while the *Locked* message is displayed.

#### Did you forget the password?

The password may be disabled by entering a master password once. If you are authorized to make changes, enter the master password 508655 to unlock the meter.

## Advanced Features Menu

To simplify the setup process, functions not needed for most applications are located in the *Advanced Features* menu.

Press and hold the Menu button for three seconds to access the advanced features of the meter.

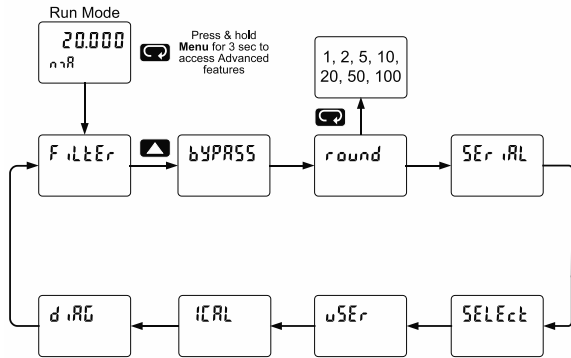

## Advanced Features Menu & Display Messages

The following table shows the functions and messages of the *Advanced Features* menu in the order they appear in the menu.

Advanced Features Menu & Display Messages		
Display	Parameter	Action/Setting
F i l t e r	Filter	Set noise filter value
b y p a s s	Bypass	Set filter bypass value
r o u n d	Round	Set the rounding value for display variables
S e r i a l	Serial	Set serial communication parameters
S l a v e I d	Slave ID	Set slave ID or meter address
b a u d	Baud rate	Select baud rate
t r a n s m i t d e l a y	Transmit delay	Set transmit delay for serial communication
P a r i t y	Parity	Select parity Even, Odd, or None with 1 or 2 stop bits
t i m e b y t e	Time byte	Set byte-to-byte timeout
S e l e c t	Select	Enter the Select menu (function, cutoff, out)
F u n c t i o n	Input signal conditioning	Select linear, square root, programmable exponent, or round horizontal tank function
L i n e a r	Linear	Set meter for linear function and select number of linearization points
P V 1	PV1	Select PV1 number of linearization points
P V 2	PV2	Select PV2 number of linearization points

Advanced Features Menu & Display Messages		
Display	Parameter	Action/Setting
n o P t 5	Number of points	Set PV1 for 2 to 32-point linearization Set PV2 for 2 to 8-point linearization
S q u a r e r o o t	Square root	Set meter for square root extraction
P r o g r a m m a b l e e x p o n e n t	Programmable exponent	Set meter for programmable exponent and enter exponent value
r o u n d h o r i z o n t a l t a n k	Round horizontal tank	Set meter for round horizontal tank volume calculation
g a l l o n s	Dimension	Calculate volume in gallons
l i t e r s	Dimension	Calculate volume in liters
d i a m e t e r	Diameter	Enter the tank's diameter in inches
L e n g t h	Length	Enter the tank's length in inches
C u t o f f	Cutoff	Set low-flow cutoff
R a n a l o g o u t p u t p r o g r a m m i n g	Analog output programming	Program analog output parameters
S o u r c e	Source	Select source for the 4-20 mA output
O v e r r a n g e	Overrange	Program mA output for display overrange
U n d e r r a n g e	Underrange	Program mA output for display underrange
B r e a k	Break	Set analog output value if input loop break is detected
M a x i m u m	Maximum	Program maximum mA output allowed
M i n i m u m	Minimum	Program minimum mA output allowed
C a l i b r a t e	Calibrate	Calibrate 4-20 mA output (internal reference source used for scaling the output)
4 m A o u t p u t	4 mA output	Enter mA output value read by milliamp meter with at least 0.001 mA resolution
20 m A o u t p u t	20 mA output	Enter mA output value read by milliamp meter with at least 0.001 mA resolution
U s e r I / O	User I/O	Assign function keys and digital I/O
F 1	F1 function key	Assign F1 function key
F 2	F2 function key	Assign F2 function key
F 3	F3 function key	Assign F3 function key
F 4	F4 function	Assign F4 function (digital input)
D i g i t a l i n p u t 1	Digital input 1	Assign digital input 1 – 4
D i g i t a l o u t p u t 1	Digital output 1	Assign digital output 1 – 4

Advanced Features Menu & Display Messages		
Display	Parameter	Action/Setting
Internal	Internal source calibration	Enter internal source calibration (used for scaling the meter without a signal source)
Current	Current calibration	Calibrate 4-20 mA current input (internal reference source used for scaling the input)
Current low	Current low	Calibrate low current input (e.g. 4 mA)
Current high	Current high	Calibrate high current input (e.g. 20 mA)
Voltage	Voltage calibration	Calibrate voltage input
Voltage low	Voltage low	Calibrate low voltage input (e.g. 0 V)
Voltage high	Voltage high	Calibrate high voltage input (e.g. 10 V)
Diagnostics	Diagnostics	Display parameter settings
LED test	LED test	Test all LEDs (press menu to exit test)
Info	Information	Display software number and version
Erase	Erase	Erase MeterView Pro SW stored in meter's memory

### Noise Filter (Filter)

The noise filter is available for unusually noisy signals that cause an unstable process variable display. The noise filter averages the input signal over a certain period. The filter level determines the length of time over which the signal is averaged. The filter level can be set between 2 and 199. The higher the filter level, the longer the averaging time and so the longer it takes the display to settle to its final value. Setting the filter level to zero disables the filter function.

### Noise Filter Bypass (Bypass)

The noise filter bypass changes the behavior of the meter so that small variations in the signal are filtered out but large abrupt changes in the input signal are displayed immediately. The bypass value determines the minimum amount of signal change to be displayed immediately. All signal changes smaller than the bypass value are filtered or averaged by the meter. The noise filter bypass may be set between 0.1 and 99.9% of full scale.

### Rounding Feature (Round)

The rounding feature is used to give the user a steadier display with fluctuating signals. Rounding is used in addition to the filter function.

Rounding causes the display to round to the nearest value according to the rounding selected. See examples below:

Rounding Selection	Actual Value	Display Value	Actual Value	Display Value
1	12.022	12.022	12.023	12.023
5	12.022	12.020	12.023	12.025
10	12.024	12.020	12.025	12.030

### Modbus® RTU Serial Communications (Serial)

The meter is equipped with serial communications capability as a standard feature using Modbus® RTU Serial Communication Protocol.

The meter may be connected to a PC for initial configuration via the on-board USB connection. For ongoing digital communications with a computer or other data terminal equipment, use the RS-485 connection.

#### CAUTION

- **DO NOT** connect any equipment to the RJ45 M-LINK connector. Otherwise damage will occur to the equipment and the meter.
- **DO NOT** disconnect the RJ45 connector located to the left of the power terminal block. Doing so will disable the on-board digital I/O, and the RS-485 serial communications.

#### Notes:

1. Refer to the ProtEX-MAX Modbus® Register Tables located at [www.prediq.com](http://www.prediq.com) for details.
2. Changes made to the Serial menu are initialized after the menu key is pressed or after navigating through the remainder of the serial parameters (i.e. pass the t-byte parameter).

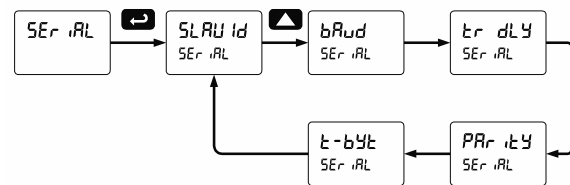

When using more than one meter in a multi-drop mode, each meter must be provided with its own unique address. The meter address (Slave ID) may be programmed between 1 and 247. The transmit delay may be set between 0 and 199 ms. The parity can be set to even, odd, or none with 1 or 2 stop bits.

### Select Menu (SELEct)

The *Select* menu is used to select the input signal conditioner applied to the input (linear, square root, programmable exponent, or round horizontal tank), low-flow cutoff, and analog output programming. The multi-point linearization is part of the linear function selection.

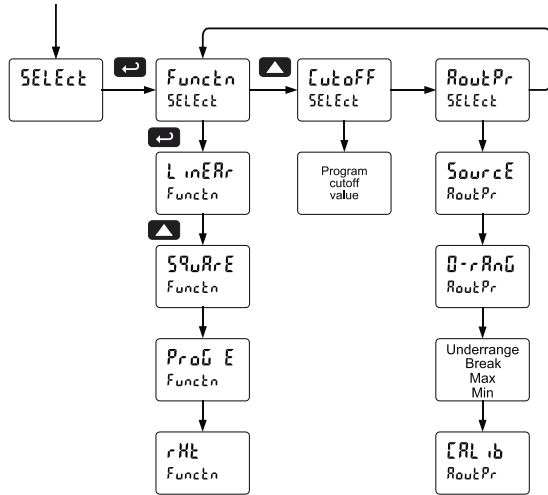

### Input Signal Conditioning (Functn)

The *Function* menu is used to select the input signal conditioner applied to the input: linear, square root, programmable exponent, or round horizontal tank volume calculation. The multi-point linearization is part of the linear function selection.

Meters are set up at the factory for linear function with 2-point linearization. The linear function provides a display that is linear with respect to the input signal.

### Square Root Linearization (SQURrE)

The square root function can be used to linearize the signal from a differential pressure transmitter and display flow rate in engineering units.

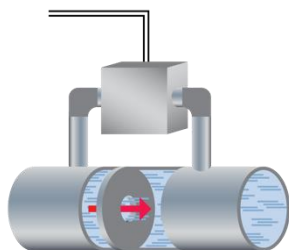

### Programmable Exponent Linearization (PrOG E)

The programmable exponent can be used to linearize the signal from level transmitters in open-channel flow applications using weirs and flumes. For more information on how the Programmable Exponent Linearization feature works, see the [PD8-6200](#) manual.

### Multi-Point Linearization (L inERr)

Meters are set up at the factory for linear function with 2-point linearization. Up to 32 linearization points can be selected for PV1 under the linear function. The multi-point linearization can be used to linearize the display for non-linear signals such as those from level transmitters used to measure volume in odd-shaped tanks or to convert level to flow using weirs and flumes with complex exponent.

If the dual-scale level feature has been selected, the menus for PV1 & PV2 are enabled. PV2 can be programmed with up to 8 linearization points.

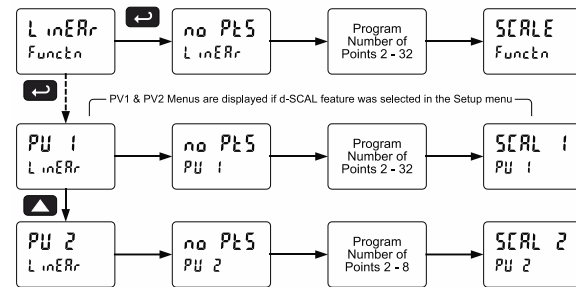

### 32-Point Linearization

The most common way to linearize a non-linear signal is to break it up into smaller ranges that are more linear than the overall range. The ProtEX-MAX is available with up to 32 points of linearization and if dual scale feature is used, the second PV can have up to eight points of linearization. The linearization data can be imported from an Excel spreadsheet or can be exported from MeterView Pro to an Excel spreadsheet. The following screen shot from MeterView Pro shows PV1 with 9 points of linearization and PV 2 with 5 points of linearization:

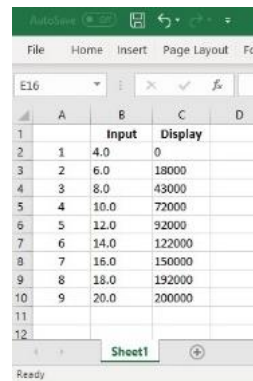
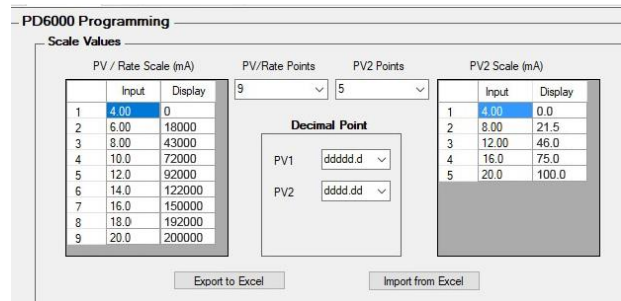

**Note:** Scale values can also be imported from an Excel spreadsheet.

### Round Horizontal Tank Linearization (rHt)

This function automatically calculates the volume in a round horizontal tank with flat ends.

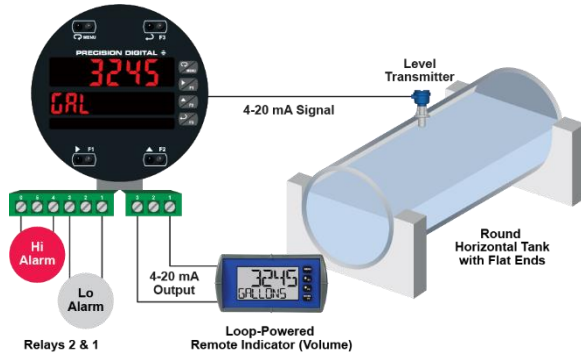

Set the display for the desired decimal point and engineering units before entering the round horizontal tank function. Select units, inches or cm for the tank dimensions. Enter the diameter and the length in inches and the results are calculated automatically in US gallons. Enter the diameter and length in cm and the results are calculated automatically in liters.

The meter can be scaled to display the volume in any engineering unit.

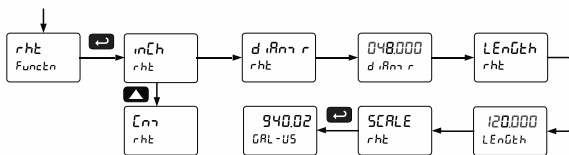

**Note:** After Scale is displayed continue pressing the Enter button until the meter completes the scaling of the input and display values.

### Changing the Volume from Gallons to Liters

In the above graphic, entering 48" for the diameter and 120" for the length of the round horizontal tank, the meter automatically calculates that the volume of the tank is 940.02 gallons.

1. Convert gallons to liters  
1 US gallon = 3.7854 L  
940.02 gal = 3558.4 L
2. Go to the *Setup* menu and change the decimal point to 1 decimal.
3. Go to the *Program – Scale* menu and press Enter until *d 5 2* is shown on the main display.
4. Press Enter and change the display 2 value to 3558.4.
5. The meter is now displaying the volume in liters.

**Note:** The display can be scaled to display the volume in any engineering units.

Another way to display the volume in liters is to enter the dimensions in cm. The meter automatically calculates the volume in liters.

### Low-Flow Cutoff (LwFF)

The low-flow cutoff feature allows the meter to be programmed so that the often-unsteady output from a differential pressure transmitter, at low flow rates, always displays zero on the meter.

The cutoff value may be programmed from 0.1 to 999999. The meter will display zero below the cutoff value. Programming the cutoff value to zero disables the cutoff feature. The cutoff can be disabled to display negative values.

### Analog Output Programming (RoutPr)

The *Analog Output Programming* menu is used to program the behavior of the 4-20 mA output. The following parameters and functions are programmed in this menu:

1. Source: Source for generating the 4-20 mA output (e.g. PV)
2. Overrange: Analog output value with display in overrange condition
3. Underrange: Analog output value with display in underrange condition
4. Break: Analog output value when loop break is detected
5. Max: Maximum analog output value allowed regardless of input
6. Min: Minimum analog output value allowed regardless of input
7. Calibrate: Calibrate the internal 4-20 mA source reference used to scale the 4-20 mA output

### Analog Output Source

The source for generating the 4-20 mA output may be assigned to the process variable, maximum or minimum value reached by the process, one of the set points, or the Modbus® PV input.

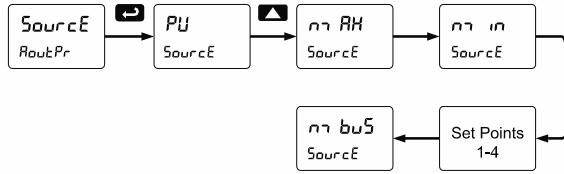

### Analog Output Value for Loss of 4-20 mA Input (Loop Break)

The *RautPr* - Break menu is used to force the analog output to go to a user-specified mA value if a break condition is detected in the 4-20 mA input loop. Selecting Ignore causes the mA output to go to the minimum value.

### Analog Output Calibration

To perform the analog output calibration, it is recommended to use a milliamp meter with a resolution of at least 0.1 µA to measure the output current. The values saved internally during this procedure are used for scaling the 4-20 mA output in the *Setup* menu.

### Analog Output Calibration Procedure

1. Wire the PD8-6000 4-20 mA output to a current loop that includes a power supply (internal or external 12 to 24 VDC), and the mA input on the digital meter. See *Figure 18. 4-20 mA Output Connections* on page 29 for details.
2. Turn on all devices. Allow for a 15 to 30 minute warm-up.
3. Go to the Advanced Features menu, navigate to Select (SELEct) and choose Analog Output Programming (RautPr) → Calibration (CALib) menu and press **Enter**.
4. The display will show 4 n n R. The PD8-6000 mA output should now be close to 4 mA. Press Enter and the display will show 04.000. Enter the actual value read by the digital mA meter and press **Enter**.
5. The display will show 20 n n R. The PD8-6000 mA output should now be close to 20 mA. Press **Enter** and the display will show 20.000. Enter the actual value read by the digital mA meter and press **Enter**.
6. The meter will now calculate the calibration factors and store them.
7. Press **Menu** to exit and return to Run mode.

### Programmable Function Keys User Menu (uSEr)

The *User* menu allows the user to assign the front programming buttons function keys F1, F2, and F3, the digital input F4 (located on the input signal connector), and four digital inputs (located on the digital I/O connector) to access most of the menus or to activate certain functions immediately (e.g. reset max & min, hold relay states, etc.). This allows the meter to be greatly customized for use in specialized applications.

The four digital outputs can be assigned to a number of actions and functions executed by the meter (i.e. alarms, relay acknowledgement, reset max, min, or max & min, tare, and reset tare). The digital outputs can be used to trigger external alarms or lights to indicate these specific events.

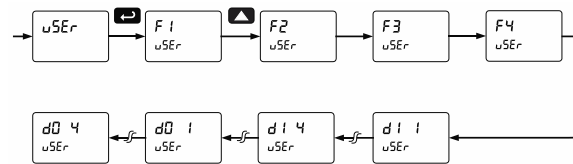

### Function Keys & Digital I/O Available Settings

Refer to the following table for descriptions of each available function key or digital I/O setting.

Function Keys & Digital I/O Available Settings	
Display	Description
r SE H i	Reset the stored maximum display value
r SE L o	Reset the stored minimum display value
r SE H L	Reset the stored maximum & minimum display values
t RR E	Capture tare and zero the display
r SE t r	Reset captured tare and resume normal operation
r EL R Y	Directly access the relay menu
SEt i *	Directly access the set point menu for relay 1 (*through 4)
r LY d	Disable all relays until a button assigned to <i>enable relays</i> (r LY E) is pressed
r LY E	Enable all relays to function as they have been programmed
d HoL d	Hold current relay states and analog output as they are until a button assigned to <i>enable relays</i> (r LY E) is pressed
d HoL d	Hold the current display value, relay states, and analog output momentarily while the function key or digital input is active. The process value will continue to be calculated in the background.
L n i H i	Display maximum display value on line 1
L n i L o	Display minimum display value on line 1

Function Keys & Digital I/O Available Settings	
Display	Description
Lb5 HL	Display maximum & minimum display values on line 1
Lb5 HI	Display maximum display value on line 2
Lb5 Lo	Display minimum display value on line 2
Lb5 HL	Display maximum & minimum display values on line 2
F On i*	Force relay 1 (*through 4) into the on state. This function is used in conjunction with a digital input to achieve interlock functionality. See <i>Setting Up the Interlock Relay (Force On) Feature</i> on page 47 for details.
Control	Directly access the control menu
disable	Disable the selected function key or digital I/O
RcH	Acknowledge all active relays that are in a manual operation mode such as auto-manual or latching
reset	Directly access the reset menu
arrow	Mimic the menu button functionality (digital inputs only)
right	Mimic the right arrow/F1 button functionality (digital inputs only)
up	Mimic the up arrow/F2 button functionality (digital inputs only)
enter	Mimic the enter/F3 button functionality (digital inputs only)
RLn i*	Provide indication when alarm 1 (*through 4) has been triggered (digital outputs only)

### Tare (tRrE)

The tare function zero's out the display. In the case of scale weight, tare is used to eliminate container weight and provide net weight readings. There are two tare functions; Capture Tare and Reset Tare. When the capture tare function is used, the display reading is offset by the displayed amount to make the displayed value zero. This modified display value is the net value. The originally displayed value without the tare offset is the gross value. Both may be chosen as a display option.



Reset tare removes the display offset of the net value, and the gross and net values become the same until a new capture tare is entered.

### Internal Source Calibration (ICRL)

The meter is **factory calibrated** prior to shipment for milliamps and volts with calibration equipment that is certified to NIST standards.

The use of calibrated signal sources is necessary to calibrate the internal source of the meter. The meter's internal source is what allows the user to scale the meter without applying a signal.

Check calibration of the meter at least every 12 months. Each input must be recalibrated separately.

**Notes:**

1. If meter is in operation and it is intended to accept only one input type (e.g. 4-20 mA), recalibration of other input is not necessary.
2. Allow the meter to warm up for at least 15 minutes before performing the internal source calibration procedure.

The *Internal calibration* menu is part of the *Advanced Features* menu.

1. Press and hold the Menu button for three seconds to access the advanced features of the meter.
2. Press the Up arrow button to scroll to the *Internal calibration* menu (ICRL) and press Enter.
3. The meter displays either current calibration (ICRL) or voltage calibration (IVRL), according to the input setup. Press Enter to start the calibration process.

**Example of Internal Calibration for current input:**

4. The meter displays *low* input current message (ILo). Apply the low input signal and press Enter. The display flashes for a moment while the meter is accepting the low input signal.
5. After the display stops flashing, a number is displayed with the leftmost digit brighter than the rest. The bright digit is the active digit that can be changed by pressing the Up arrow button. Press the Right arrow button to move to the next digit.
6. Set the display value to correspond to the input signal being calibrated, typically 4.000 mA.
7. The display moves to the *high* input calibration (IHi). Apply the high input signal and press Enter.
8. Set the display for the high input calibration, in the same way as it was set for the low input calibration, typically 20.000 mA.

The following graphic shows the calibration of the current input. The voltage input is calibrated in a similar way.

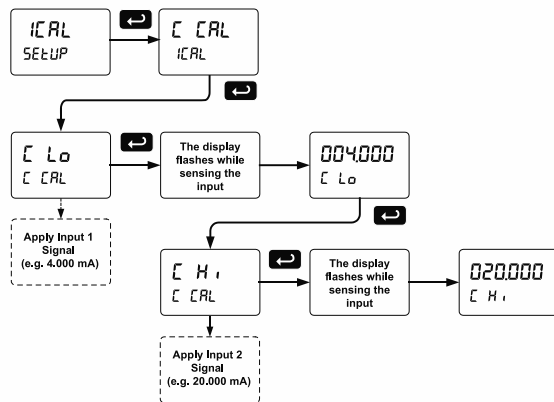

**Tips:**

- Low and high input signals can be any valid values within the range of the meter.
- Observe minimum input span requirements between input 1 and input 2.
- Low input should be less than high input signal. However, the low display can be higher than the high display (i.e. 4-20 mA = 100.0 to 0.0).

**Error Message (Error)**

An error message indicates that the calibration or scaling process was not successful.

After the error message is displayed, the meter reverts to the input prior to the failure during calibration or scaling and to input 1 during internal calibration, allowing the appropriate input signal to be applied or programmed.

The error message might be caused by any of the following conditions:

1. Input signal is not connected to the proper terminals or it is connected backwards\*.
2. Wrong signal selection in *Setup* menu\*.
3. Minimum input span requirements not maintained.
4. Input 1 signal inadvertently applied to calibrate input 2\*.

*\*Not relevant when scaling the meter.*

**Minimum Input Span**

The minimum input span is the minimum difference between input 1 and input 2 signals required to complete the calibration or scaling of the meter.

Input Range	Input 1 & Input 2 Span
4-20 mA	0.15 mA
±10 VDC	0.10 VDC

**Meter Operation**

When installed, the primary way to operate the meter is with the SafeTouch through-glass buttons that allow the user to perform various operations without removing the cover and exposing the electronics to the hazardous environment. The user can also operate the meter by connecting a suitable control station or switch to one of the digital inputs that can be used to perform various operations on the meter based on the Programmable Function Keys. Finally, certain operations can be performed on the meter with MeterView Pro software or through Modbus® commands.

The two default operations that can be performed with the meter’s SafeTouch buttons are:

1. Display the maximum and minimum readings
2. Acknowledge the relays

In addition, the user can program the SafeTouch Buttons to perform a variety of useful operations by reassigning them to other functions per *Function Keys & Digital I/O Available Settings* on page 54.

**Button Operation**

The following table shows the default operations for the F1, F2, and F3 SafeTouch Buttons, Displaying and resetting the maximum and minimum values and resetting the relays:

Button Symbol	Description
	Press to enter or exit Programming Mode, view settings, or exit max/min readings
	Press to reset max/min readings or other parameter/function assigned through the <i>User</i> menu
	Press to display max/min readings or other parameter/function assigned through the <i>User</i> menu
	Press to acknowledge relays or other parameters/function assigned through the <i>User</i> menu



**To learn more about SafeTouch buttons, see this video:**

[predig.com/videos/Safetouch\\_Buttons](https://predig.com/videos/Safetouch_Buttons)

### SafeTouch Buttons

The ProtEX-MAX is equipped with four sensors that operate as through-glass buttons so that it can be programmed and operated without removing the cover (and exposing the electronics) in a hazardous area.

These buttons can be disabled for security by selecting DISABLE on the switch labeled NO-CONTACT BUTTONS located on the connector board.



To actuate a button, press one finger to the glass directly over the marked button area. Then retract finger more than three inches from the glass before pressing the next button. When the cover is removed, the four mechanical buttons located next to the sensors are used. The sensors are disabled when a mechanical button is pressed and will automatically be re-enabled after 60 seconds of inactivity.

The SafeTouch Buttons are designed to filter normal levels of ambient interference and to protect against false triggering, however, it is recommended that the SafeTouch Buttons be disabled (slide switch to DISABLE) if there is an infrared interference source in line-of-sight to the display.

The SafeTouch Buttons are configured by default to duplicate the function of the front panel mechanical pushbuttons associated with the integrated meter. The symbols by each SafeTouch button correspond to a mechanical button as shown in the above table.

### SafeTouch Button Tips:

- To the extent possible, install the display facing away from sunlight, windows, reflective objects and any sources of infrared interference.
- Keep the glass window clean.
- Tighten the cover securely.
- Use a password to prevent tampering.

### Function Keys Operation

During operation, the programmable function keys operate according to the way they have been programmed in the *Advanced Features – User* menu. See *Programmable Function Keys User Menu (u5Er)* on page 54 for details.

The table above shows the factory default settings for F1, F2, and F3.

### Digital Inputs Operation

Five (5) digital inputs, F4, DI-1 to DI-4, come standard on the meter. These digital inputs are programmed identically to function keys F1, F2, and F3. The inputs are triggered with a contact closure to +5 in the case of digital inputs 1-4 or with an active high signal, see *Digital I/O Connections* on page 29 for details. The F4 is triggered with a contact closure to COM or with an active low signal. During operation, digital inputs operate according to the way they are programmed in the *Advanced Features – User* menu. See *Programmable Function Keys User Menu (u5Er)* on page 54 for details.

### Maximum/Minimum Readings

The max & min readings (peak & valley) reached by the process can be displayed either continuously or momentary:

1. Display briefly by assigning to the F1-F3 function keys or to the digital inputs in the *User* menu.
2. Display continuously by assigning either display to max/min through the *Display* menu.

Any of the F1-F3 function keys (buttons) and the digital inputs can be programmed to reset the max & min readings. The meters are set at the factory to display the max reading by pressing the Up arrow/F2 button and to use the Right arrow/F1 button to access the *Reset* menu.

#### To display max reading using function key with factory defaults:

1. Press Up arrow/F2 button to display maximum reading since the last reset/power-up.
2. To reset max/min press Right arrow/F1 button to access the *Reset* menu. The max & min displays are reset to actual values.
3. Press Menu to exit max/min display reading.

#### To display max/min readings continuously:

Assign either display to Max (d H i), Min (d L o), or toggle between Max and Min (d H L) every 10 seconds.

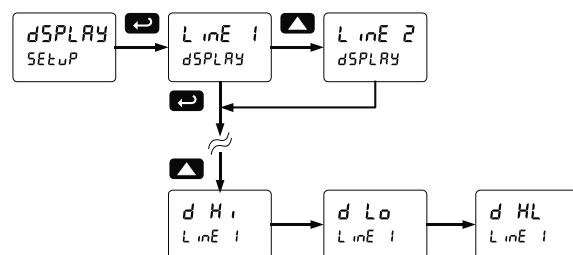

## Troubleshooting

The rugged design and the user-friendly interface of the meter should make it unusual for the installer or operator to refer to this section of the manual. However, due to the many features and functions of the meter, it's possible that the setup of the meter does not agree with what an operator expects to see.

If the meter is not working as expected, refer to the *Diagnostics* menu and recommendations below.

## Diagnostics Menu (d ,RŁ)

The *Diagnostics* menu is located in the *Advanced Features* menu, to access *Diagnostics* menu see *Advanced Features Menu* on page 50.

This menu allows the user to test the functionality of all the meter LEDs, check the meter's software and version information, and erase the MeterView Pro software installation files from the meter. Press the Enter button to view the settings and the Menu button to exit at any time.

For a description of the diagnostic messages, see *Advanced Features Menu & Display Messages* on page 50.

### Testing the Display LEDs

To test all LEDs on the display:

1. Go to the *Diagnostics* menu (d ,RŁ) and press Enter button.
2. Press Up arrow button and scroll to *LED Test* menu (LŁd Ł).
3. Press the Enter button to activate the LED Test. The meter will cycle through all digits, decimal points, and relay indicators to enable the operator to check that all LEDs are functioning properly.
4. Press the Enter button again to access the *Information* menu ( ,nFŁ) or press the Menu button to return to Run Mode.

### Determining Software Version

To determine the software version of a meter:

1. Go to the *Diagnostics* menu (d ,RŁ) and press Enter button.
2. Press Up arrow button and scroll to *Information* menu ( ,nFŁ).
3. Press Enter to access the software number (5FŁ) and version (ŁŁr) information. Write down the information as it is displayed. Continue pressing Enter until all the information is displayed.
4. The meter returns to Run Mode after displaying all the settings.

## Reset Meter to Factory Defaults

When the parameters have been changed in a way that is difficult to determine what's happening, it might be better to start the setup process from the factory defaults.

### Instructions to load factory defaults:

1. Enter the *Advanced Features* menu. See *Advanced Features Menu* on page 50.
2. Press Up arrow to go to *Diagnostics* (d ,RŁ) menu
3. Press and hold Right arrow for three seconds, press Enter when display flashes rŁŁŁŁ.
- Note:** If Enter is not pressed within three seconds, the display returns to the *Diagnostics* menu.
4. The meter goes through an initialization sequence (similar as on power-up), and loads the factory default settings.

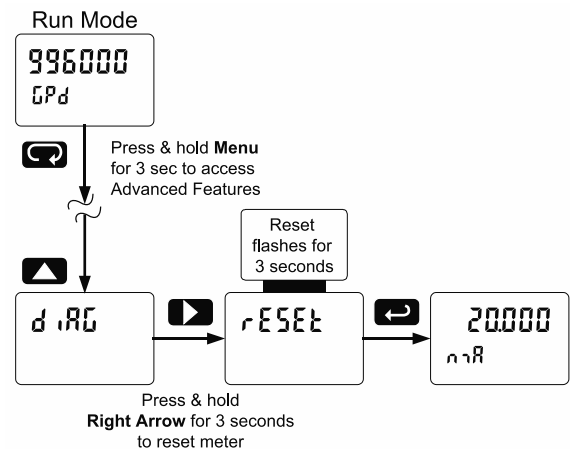

### Factory Defaults & User Settings

The following table shows the factory setting for most of the programmable parameters on the meter.

Parameter	Display	Default Setting
Input type	inPut	4-20 mA
Dual-scale feature	d-5LR	No (Single scale)
Filter	FiltEr	70
Bypass	bYPASS	0.2
Function	FunctiOn	Linear
Number of points	no Pts	2
Programming	Pr oG	Scale
Input 1	inP 1	4.000 mA
Display 1	d 15 1	4.000
Input 2	inP 2	20.000 mA
Display 2	d 15 2	20.000
Decimal point	dddd	3 places
Cutoff value	Cu toFF	0.0 (disabled)
Display assignment	d5PLRY	
Display Line 1	L inE 1	PV: Process variable
Display Line 2	L inE 2	Eng unit default= mA
Display intensity	d- inEY	6
Relay 1 action	Rc t 1	Automatic
Relay 1 set point	SEt 1	1.000
Relay 1 reset point	r SEt 1	0.500
Relay 2 action	Rc t 2	Automatic
Relay 2 set point	SEt 2	2.000
Relay 2 reset point	r SEt 2	1.500
Relay 3 action	Rc t 3	Automatic
Relay 3 set point	SEt 3	3.000
Relay 3 reset point	r SEt 3	2.500
Relay 4 action	Rc t 4	Automatic
Relay 4 set point	SEt 4	4.000
Relay 4 reset point	r SEt 4	3.500
Fail-safe relay 1	FLS 1	Off
Fail-safe relay 2	FLS 2	Off
Fail-safe relay 3	FLS 3	Off
Fail-safe relay 4	FLS 4	Off
On delay relay 1	On 1	0.0 sec
Off delay relay 1	OFF 1	0.0 sec
On delay relay 2	On 2	0.0 sec
Off delay relay 2	OFF 2	0.0 sec

Parameter	Display	Default Setting
On delay relay 3	On 3	0.0 sec
Off delay relay 3	OFF 3	0.0 sec
On delay relay 4	On 4	0.0 sec
Off delay relay 4	OFF 4	0.0 sec
Loop break relay 1	inorE	Ignore
Loop break relay 2	inorE	Ignore
Loop break relay 3	inorE	Ignore
Loop break relay 4	inorE	Ignore
Display 1 analog out	d 15 1	4.000
Output 1 value	Out 1	4.000 mA
Display 2 analog out	d 15 2	20.000
Output 2 value	Out 2	20.000 mA
Source analog output	SourceE	Process Variable
Overrange output	O-rRnE	21.000 mA
Underrange output	u-rRnE	3.000 mA
Loop break output	brERH	1.000 mA
Maximum output	max	23.000 mA
Minimum output	min	1.000 mA
Slave ID (Address)	SLR id	247
Baud rate	bRud	9600
Transmit delay	tr dLY	50 ms
Parity	PRr tEY	Even
Byte-to-byte timeout	t-bYE	010 (0.1 sec)
F1 function key	F 1	Reset max & min
F2 function key	F 2	Line 1: Max (Hi)
F3 function key	F 3	Acknowledge relays
F4 function	F 4	Acknowledge relays
Digital input 1	d i 1	Menu
Digital input 2	d i 2	Right arrow
Digital input 3	d i 3	Up arrow
Digital input 4	d i 4	Enter
Digital output 1	dO 1	Alarm 1
Digital output 2	dO 2	Alarm 2
Digital output 3	dO 3	Alarm 3
Digital output 4	dO 4	Alarm 4
Password 1	PR55 1	000000 (unlocked)
Password 2	PR55 2	000000 (unlocked)
Password 3	PR55 3	000000 (unlocked)

## Troubleshooting Tips

This meter is a highly sophisticated instrument with an extensive list of features and capabilities. If the programming buttons are used to program the meter, it may be a difficult task to keep everything straight. That is why we strongly recommend the use of the free [MeterView Pro](#) software for all programming activities. A USB cable is provided with the meter for programming with MeterView Pro software.

If you have programmed the meter with the programming buttons and it is not working as intended, try re-programming the meter using MeterView Pro software.

Symptom	Check/Action
No display at all	Check power at power connector
Not able to change setup or programming, <b>LoCd</b> is displayed	Meter is password-protected; enter correct six-digit password to unlock or Master Password of 508655
Meter does not respond to input change	If a <i>Low-Flow Cutoff Value</i> has been programmed, the meter will display zero below that point, regardless of the input – which can appear like the meter is not responding to an input change. Check to make sure the problem is not being caused by an undesired low-flow cutoff value. To prevent the display from showing a negative value, set the low-flow cutoff to a value greater than zero.
Meter displays error message during calibration ( <b>Error</b> )	Check: <ol style="list-style-type: none"> <li>1. Signal connections</li> <li>2. Input selected in <i>Setup</i> menu</li> <li>3. Minimum input span requirements</li> </ol>
Meter displays <ol style="list-style-type: none"> <li>1. <b>999999</b></li> <li>2. <b>-999999</b></li> </ol>	Check: <ol style="list-style-type: none"> <li>1. Input selected in <i>Setup</i> menu</li> <li>2. Corresponding signal at Signal connector</li> </ol>
Display is unstable	Check: <ol style="list-style-type: none"> <li>1. Input signal stability and value</li> <li>2. Display scaling vs. input signal</li> <li>3. Filter and bypass values (increase)</li> </ol>
Display response is too slow	Check filter and bypass values
Display reading is not accurate	Check: <ol style="list-style-type: none"> <li>1. Input signal conditioner selected: Linear, square root, etc.</li> <li>2. Scaling or calibration</li> </ol>
Display does not respond to input changes, reading a fixed number	Check display assignment, it might be displaying max, min, or set point
Display alternates between <ol style="list-style-type: none"> <li>1. <b>H</b> and a number</li> <li>2. <b>Lo</b> and a number</li> </ol>	Press Menu to exit max/min display readings
Relay operation is reversed	Check: <ol style="list-style-type: none"> <li>1. Fail-safe in <i>Setup</i> menu</li> <li>2. Wiring of relay contacts</li> </ol>
Relay and status LED do not respond to signal	Check: <ol style="list-style-type: none"> <li>1. Relay action in <i>Setup</i> menu</li> <li>2. Set and reset points</li> </ol>
Flashing relay status LEDs	Relays in manual control mode or relay interlock switches opened
Meter not communicating with application programs	Check: <ol style="list-style-type: none"> <li>1. M-Link Connector installed between PROVU electronics and ProtEX-MAX connector board. See <i>Figure 4: Integrated PROVU Required Connections</i> on page 25</li> <li>2. Serial settings</li> <li>3. Meter address and baud rate</li> </ol>
If the display locks up or the meter does not respond at all	Cycle the power to reboot the microprocessor

## Troubleshooting Tips

Symptom	Check/Action
SafeTouch buttons do not respond	<ol style="list-style-type: none"> <li>1. If mechanical button was pushed, the SafeTouch buttons will be re-enabled automatically 60 seconds after the last button push.</li> <li>2. If slide switch on connector board is in DISABLE position, switch to ENABLE.</li> <li>3. Strong direct sunlight may interfere with SafeTouch button operation. It is recommended to operate the buttons by standing so as to block direct sunlight.</li> </ol>
Serial Communications Power LED Indicator is off	Check: <ol style="list-style-type: none"> <li>1. Modular cable connection</li> <li>2. Power to the device</li> </ol>
If only the TX (or DATA IN) data status LED is flashing when serial communications attempted	Check: <ol style="list-style-type: none"> <li>1. Serial cable</li> <li>2. Protocol selected on device</li> <li>3. Instrument address &amp; baud rate</li> <li>4. Program address &amp; baud rate</li> </ol>
If both data status LEDs (TX and RX) are off when trying to communicate	Remove all unnecessary cables and instruments from the bus. Try getting the system to work with only one device (to ease troubleshooting) and then expand the system one device at a time.
Communications slow	Increase the baud rate
Random communication errors	<ol style="list-style-type: none"> <li>1. Increase the TX delay time</li> <li>2. Decrease the baud rate</li> </ol>
Other symptoms not described above	Call Technical Support for assistance

**Note:** Certain sequences of events can cause unexpected results. To solve these issues, it is best to start fresh from factory defaults and use the manual as a step by step programming guide, rather than a random approach to programming. To reset the meter to factory defaults, see *Reset Meter to Factory Defaults* on page 58. In addition, for best results, we recommend using the free MeterView Pro software for all programming needs.

**NOTES**

# Complete Product Line of Displays and Controllers IN ALL SHAPES, SIZES & LOCATIONS



Big, Bright Displays  
For Indoor or Outdoor  
in Bright Sunlight



Large Dual-Line  
6-Digit Display



24 VDC  
Transmitter  
Power Supply



MeterView® Pro USB  
Programming Software



Universal 85-265  
VAC or 12-24 VDC  
Input Power  
Options



4-20 mA, 0-10 V,  
Thermocouple, RTD,  
Strain Gauge, High  
Voltage, & Modbus Inputs



Up To Four  
3 A Form C  
Relays (SPDT)

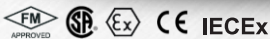

## EXPLOSION-PROOF ProtEX-MAX Series

- NEMA 4X, IP68 Rated Enclosure
- SafeTouch® Through-Glass Buttons
- Operating Temperature of -40 to 65°C
- Worldwide Approvals

## LARGE DISPLAYS Helios Series

- 1.8" Digits Readable From 100 Feet
- NEMA 4X, IP65 Rated Enclosure
- Operating Temperature of -40 to 65°C
- Now UL and C-UL Approved!



## PANEL METERS ProVu Series

- NEMA 4X, IP65 Rated Front
- Programmable Function Keys
- UL, C-UL, and CE Approvals
- 1/8 DIN Size

Go to [PREDIG.COM](http://PREDIG.COM) for details on ProVu, ProtEX-MAX and Helios Series Meters

## Contact Precision Digital

### Technical Support

Call: (800) 610-5239 or (508) 655-7300

Fax: (508) 655-8990

Email: [support@predig.com](mailto:support@predig.com)

### Sales Support

Call: (800) 343-1001 or (508) 655-7300

Fax: (508) 655-8990

Email: [sales@predig.com](mailto:sales@predig.com)

### Place Orders

Email: [orders@predig.com](mailto:orders@predig.com)

For the latest version of this manual please visit

[www.predig.com](http://www.predig.com)

### PRECISION DIGITAL CORPORATION

233 South Street • Hopkinton MA 01748 USA

Tel (800) 343-1001 • Fax (508) 655-8990

[www.predig.com](http://www.predig.com)

