

PD8-6060 Explosion-Proof Dual Analog Input Process Meter

Instruction Manual



MeterView Pro

USB Install

- Fully-Approved Explosion-Proof Meter
- Dual 0-20 mA, 4-20 mA, 0-5 V, 1-5 V, and ± 10 V Inputs with Math Functions
- Addition, Difference, Average, Multiplication, Division, Minimum, Maximum, Ratio, & More
- Dual-Line 6-Digit Display, 0.6" (15 mm) & 0.46" (12 mm)
- SafeTouch Through-Glass Button Programming
- Display Mountable at 0°, 90°, 180°, & 270°
- Isolated 24 VDC @ 25 mA Transmitter Power Supply
- Easy Field Scaling in Engineering Units without Applying an Input
- 4 Relays with Interlocking Capability + Isolated 4-20 mA Output Option
- Free PC-Based, On-Board, MeterView Pro USB Programming Software
- SunBright Display Standard Feature; Great for Outdoor Applications
- Operating Temperature Range: -40 to 60°C (-40 to 140°F)
- FM Approved as Explosion-Proof / Dust-Ignition-Proof / Flame-Proof
- CSA Certified as Explosion-Proof / Dust-Ignition-Proof / Flame-Proof
- ATEX and IECEx Certified as Flame-Proof
- Input Power Options: 85-265 VAC / 90-265 VDC or 12-24 VDC / 12-24 VAC
- Multi-Pump Alternation Control
- Password Protection
- 32-Point Linearization, Square Root Extraction and Programmable Exponent Function
- Round Horizontal Tank Function; Just Enter Diameter & Length
- Programmable Display, Function Keys & Digital Inputs
- Flanges for Wall or Pipe Mounting
- Explosion-Proof, IP68, NEMA 4X Die-Cast Aluminum Enclosure
- On-Board RS-485 Serial Communications Standard
- Modbus® RTU Communication Protocol Standard
- Four 3/4" NPT Threaded Conduit Openings (Two Plugs Installed)
- Pipe Mounting Kits
- Stainless Steel Tag Available
- 3-Year Warranty

PRECISION DIGITAL CORPORATION

233 South Street • Hopkinton MA 01748 USA
Tel (800) 343-1001 • Fax (508) 655-8990
www.predig.com



The Complete **ProtEX™** Series

MAX



PD8-154
**4-Point Alarm
Annunciator**



PD8-6100
Strain Gauge Meter



PD8-158
**8-Point Alarm
Annunciator**



PD8-6200
**Analog Input
Flow Rate/Totalizer**



PD8-765
**Process &
Temperature Meter**



PD8-6210
**Analog Input Batch
Controller**



PD8-6000
Process Meter



PD8-6262
**Analog Dual-Input
Flow Rate/Totalizer**



PD8-6001
**Feet & Inches
Level Meter**



PD8-6300
**Pulse Input
Flow Rate/Totalizer**



PD8-6060
**Dual-Input
Process Meter**



PD8-6310
**Pulse Input
Batch Controller**



PD8-6080
**Modbus® Scanner
with Dual Analog Input**



PD8-6363
**Pulse Dual-Input
Flow Rate/Totalizer**



PD8-6081
**Feet & Inches
Modbus® Scanner**



PD8-7000
Temperature Meter

Go to PREDIG.COM for details on the entire ProtEX-MAX Series Meters

Disclaimer

The information contained in this document is subject to change without notice. Precision Digital makes no representations or warranties with respect to the contents hereof and specifically disclaims any implied warranties of merchantability or fitness for a particular purpose. See Warranty Information and Terms & Conditions on www.prediq.com for complete details.

CAUTION

- Read complete instructions prior to installation and operation of the meter.

WARNINGS

- Risk of electric shock or personal injury.
- This product is not recommended for life support applications or applications where malfunctioning could result in personal injury or property loss. Anyone using this product for such applications does so at his/her own risk. Precision Digital Corporation shall not be held liable for damages resulting from such improper use.
- Failure to follow installation guidelines could result in death or serious injury. Make sure only qualified personnel perform the installation.
- Never remove the meter cover in explosive environments when the circuit is live.
- Cover must be fully engaged to meet explosion-proof/dust-ignition-proof/flame-proof requirements.

WARNING

Cancer and Reproductive Harm - www.P65Warnings.ca.gov

Limited Warranty

Precision Digital Corporation warrants this product against defects in material or workmanship for the specified period under "Specifications" from the date of shipment from the factory. Precision Digital's liability under this limited warranty shall not exceed the purchase value, repair, or replacement of the defective unit. See Warranty Information and Terms & Conditions on www.prediq.com for complete details.

Registered Trademarks

All trademarks mentioned in this document are the property of their respective owners.

© 2022 Precision Digital Corporation.
All rights reserved.

FREE MeterView Pro Programming Software



The meter can be powered from the USB connection. When using the USB connection, **DO NOT** apply AC or DC power to the meter.

The easiest and quickest way to program your ProtEX-MAX meter is to use the FREE MeterView Pro programming software. This software is loaded into the meter and connects and installs directly to your PC with a USB cable. We recommend that the first thing you do after taking the meter out of the box is connect the ProtEX-MAX to your PC with the provided USB cable – do not use a different cable. **DO NOT** apply AC or DC power to the meter while your PC is connected to the meter as it will disrupt the USB connection. You don't even have to apply an input signal.

MeterView Pro programming software is intuitive, and most customers can get their meter programmed as they like without even looking in the manual.

Watch MeterView Pro Software Video at
www.prediq.com/meterviewpro

In addition to programming, the software may be used for:

- Monitoring
- Datalogging using your PC
- Generating and saving programming files for later use

Once your meter is programmed the way you want it, you can wire it up for your application per the instructions in this manual and install it. If you find that you need to make adjustments to the programming after the meter is installed, you can use the programming buttons and the instructions in this manual to do so.

WARNING

- The meter should only be connected to a computer while it is located in a safe area.

Table of Contents

Introduction.....	7
Ordering Information.....	7
Key Features.....	9
Specifications	18
General.....	18
Dual Process Inputs	19
Relays	19
USB Connection.....	20
Isolated 4-20 mA Transmitter Output	20
RS-485 Serial Communications	20
Modbus® RTU Serial Communications	20
Digital Input (F4).....	20
Digital Inputs & Outputs	21
MeterView Pro Software	21
Compliance Information.....	21
Electromagnetic Compatibility	21
Product Ratings and Approvals	22
EU Declaration of Conformity.....	23
Safety Information	23
Installation.....	23
Unpacking.....	23
Mounting.....	24
Installation Overview	26
MeterView Pro Software	26
Transmitter Supply Voltage Selection (P+, P-).....	27
Connections	27
Required & Factory Wired Connection.....	27
ProVu Electronics Module Layout	28
USB Connection	28
Power Connections.....	29
Signal Connections.....	29
RS-485 Connections.....	30
RS-485 Multi-Drop Connection	30
Digital I/O Connections	31
F4 Digital Input Connections.....	31
Remote Programming.....	31
4-20 mA Output Connections.....	31
Analog Output Power Supply	31
Relay Connections.....	32
Interlock Relay Feature	32
Switching Inductive Loads.....	32
Setup and Programming.....	33
Overview	33
LED Status Indicators.....	33
Programming Buttons	34
SafeTouch Buttons	34
Display Functions & Messages	35
Main Menu	37
Setting Numeric Values.....	37
Setting Up the Meter (SEtUP).....	37
Setting the Input Signal (InPUt).....	38
Setting the Display Units or Custom Tags (unItS)	38
Setting the Decimal Point (dEc Pnt)	39
Programming the Meter (PrOG)	39
Setting the Display Parameter & Intensity (dSPLRy)	41

- Setting the Relay Operation (rELRY)..... 42**
 - Setting the Relay Assignment (R55 iEn)..... 42
 - Setting the Relay Action..... 42
 - Programming Set and Reset Points 43
 - Setting Fail-Safe Operation..... 43
 - Programming Time Delay 43
 - Relay Action for Loss of 4-20 mA Input (Loop Break) 43
- Relay and Alarm Operation Diagrams..... 43**
 - High Alarm Operation (Set > Reset) 43
 - Low Alarm Operation (Set < Reset) 44
 - High Alarm with Fail-Safe Operation (Set > Reset)..... 44
 - Low Alarm with Fail-Safe Operation (Set < Reset)..... 44
 - Time Delay Operation 44
 - Pump Alternation Control Operation 45
 - Relay Sampling Operation 45
- Relay Operation Details..... 46**
 - Overview 46
 - Relays Auto Initialization 46
 - Fail-Safe Operation..... 46
 - Front Panel LEDs..... 46
 - Latching and Non-Latching Relay Operation 46
 - Non-Latching Relay (RuLo) 47
 - Non-Latching Relay with Manual Reset (R-nRn)..... 47
 - Latching Relay (LRcH) 47
 - Latching Relay with Clear (Lc-Lr) 47
 - Acknowledging Relays 48
 - Pump Alternation Control Applications (RLtErn) 48
 - Setting Up the Interlock Relay (Force On) Feature 49
- Scaling the 4-20 mA Analog Output (Rout)..... 50**
- Reset Menu (rESEt) 50**
- Manual Control Menu (ContRL) 50**
- Setting Up the Password (PR55) 51**
 - Protecting or Locking the Meter 51
 - Making Changes to a Password Protected Meter 51
 - Disabling Password Protection 51
- Advanced Features Menu..... 52**
 - Advanced Features Menu & Display Messages..... 52
 - Noise Filter (F iLtEr) 53
 - Noise Filter Bypass (bYPR55)..... 53
 - Rounding Feature (round) 54
 - Modbus® RTU Serial Communications (5Er iRL) 54
 - Select Menu (5ELtEt)..... 54
 - Input Signal Conditioning (FuncEtN)..... 54
 - Square Root Linearization (5RuRrE) 55
 - Math Constants (ConSt)..... 56
 - Low-Flow Cutoff (CutOFF)..... 56
 - Analog Output Programming (RoutPr) 57
 - Programmable Function Keys User Menu (u5Er) 58
 - Tare (tRrE) 59
 - Internal Calibration (iRL)..... 59
- Meter Operation..... 60**
 - Button Operation 60**
 - SafeTouch Buttons 60**
 - Function Keys Operation 61**
 - Digital Inputs Operation 61**
 - Maximum/Minimum Readings..... 61**
- Troubleshooting 62**
 - Diagnostics Menu (d iRL)..... 62**
 - Testing the Display LEDs..... 62
 - Determining Software Version 62
 - Reset Meter to Factory Defaults 62**
 - Factory Defaults & User Settings 63
 - Troubleshooting Tips 65**

Table of Figures

Figure 1. Enclosure Dimensions – Front View.....	24
Figure 2. Enclosure Dimensions – Side Cross Section View	24
Figure 3. Transmitter Supply Voltage Selection	27
Figure 4. Integrated PROVu Required Connections	27
Figure 5. PROVu Electronics Module Layout	28
Figure 6. USB Connection	28
Figure 7. Power Connections	29
Figure 8. 2-Wire Transmitters Powered by Internal Supply	29
Figure 9. 3-Wire Transmitters Powered by Internal Supply	29
Figure 10. Transmitter Powered by External Supply	29
Figure 11. Self-Powered Transmitters	29
Figure 12. 2-Wire Voltage Input Connections	29
Figure 13. 3-Wire Voltage Input Connections	29
Figure 14. RS-485 Connection.....	30
Figure 15. Three-Wire RS-485 Connection	30
Figure 16. Digital Input and Output Connections	31
Figure 17. F4 Digital Input Connections	31
Figure 18. 4-20 mA Output Connections	31
Figure 19. Analog Output Supply Powering Other Devices.....	31
Figure 20. Relay Connections	32
Figure 21. Interlock Connections	32
Figure 22. AC and DC Loads Protection.....	32
Figure 23. Low Voltage DC Loads Protection	32

Introduction

The ProtEX MAX PD8-6060 is an explosion-proof dual-input process meter that accepts, powers, and displays two analog inputs, such as 4-20 mA or 0-10 V. In its simplest configuration, the meter can display these two inputs at the same time on its dual-line display in user desired engineering units. For more demanding applications, the meter can display a mathematical function of these two inputs such as addition, difference, average, multiplication and more. The meter is ideal for level, flow rate, temperature, or pressure transmitter applications.

The meter features a dual-line display, with a main display 0.60" (15 mm) high, and a second display of 0.46" (12 mm) high superluminous LED digits, which can be read in any lighting condition, including direct sunlight. The meter is housed in a die-cast aluminum, field-mountable, NEMA 4X/IP68 rated enclosure for convenient indoor and outdoor installation.

The ProtEX-MAX is available in two configurations: display only and fully loaded. Both versions include a 24 VDC power supply to power the transmitter. A fully loaded ProtEX-MAX PD8-6060-6H7 meter comes with four SPDT relays, a 4-20 mA output, five digital inputs and four digital outputs, and RS-485 serial communications.

The four relays can be used for alarm indication or process control applications such as pump alternation control. The 4-20 mA isolated output, Modbus® RTU serial communications, and digital I/O features make the ProtEX-MAX an excellent addition to any system.

SafeTouch Buttons

To make it possible to program and operate the ProtEX-MAX in a hazardous area, the programming buttons that are located behind the glass window can be operated without removing the cover by using the SafeTouch through-glass buttons. The operator puts their finger on the glass over the button and the button is actuated.



To learn more about SafeTouch buttons, see this video:

predig.com/videos/Safetouch_Buttons

Ordering Information

85-265 VAC Models

Model	Standard Features	Options Installed
PD8-6060-6H0	5 Digital Inputs, 4 Digital Outputs, RS-485 Communications	No options
PD8-6060-6H7		4 relays 4-20 mA output

12-24 VDC Models

Model	Standard Features	Options Installed
PD8-6060-7H0	5 Digital Inputs, 4 Digital Outputs, RS-485 Communications	No options
PD8-6060-7H7		4 relays 4-20 mA output

Accessories

Model	Description
PDA0001	3/4" M-NPT to F-M20 Reducer
PDA0002	3/4" M-NPT to 1/2" F-NPT Reducer
PDAPLUG75	3/4" Metal Conduit/Stopping Plug
PDA-SSTAG	Custom Stainless Steel Tag (see website for convenient ordering form)
PDA6848	2" U-Bolt Kit Zinc Plated Steel
PDA6848-SS	2" U-Bolt Kit Stainless Steel

Helpful Videos

There are several videos that will help you get a better understating of the features and functionality of the ProtEX-MAX products. Since the ProtEX-MAX meters have the same general features and functionality of the ProVu meters, appropriate videos for the ProVu meter are also included.

ProtEX-MAX Products Overview

Learn about the complete line of ProtEX-MAX products.



predig.com/videos/ProtEXMAX_Overview

MeterView Pro Programming Software

Learn how easy it is to program the ProVu (ProtEX-MAX) process meter using MeterView Pro software.



predig.com/videos/MVPro_SW

MeterView Pro Software Demonstration

Learn how easy it is to program Precision Digital's ProVu (ProtEX-MAX) process meter for a level application using MeterView Pro PC-based programming software.

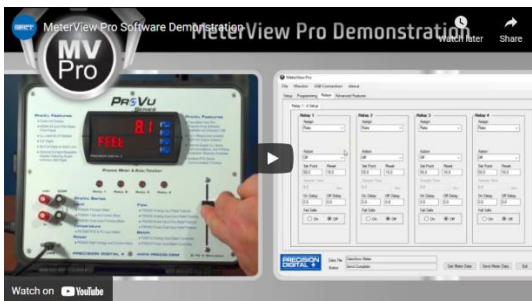

predig.com/videos/MVPro_Demo

Connect to PC for Programming

Learn how to connect a ProVu (ProtEX-MAX) process meter to your PC and install free MeterView Pro programming software.



predig.com/videos/PC_Connect

4-20 mA Connections

This Tech Tips video shows how to make connections to power the transmitter with the ProVu's (ProtEX-MAX's) 24 VDC power supply.



predig.com/videos/4-20_mA_Connections

Use ProtEX-MAX for Pump Control

Learn how to use the ProVu (ProtEX-MAX) meter as an explosion-proof pump controller. See how the four relays can be used to alternate two pumps and provide high and low alarms.



predig.com/videos/PumpControl

Dual-Input Process Meter

Learn about the dual-input display, math capabilities, and other great features that make this one of the most power Precision Digital meters available.

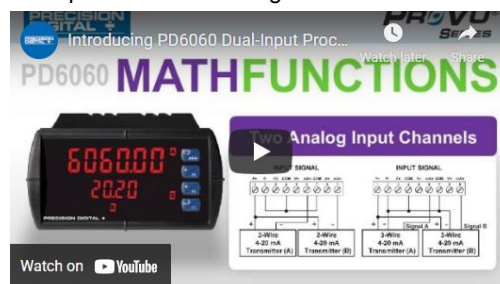

https://www.predig.com/PD6060_Dual_Input_Intro

Key Features



CONNECTIONS

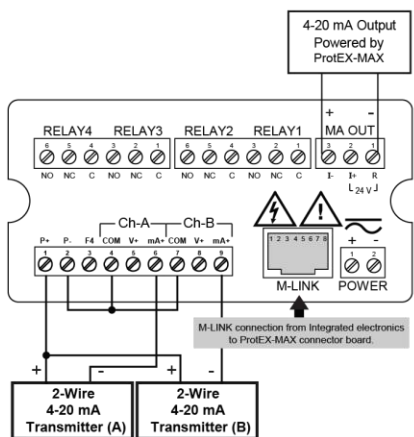

RS-485 Connections

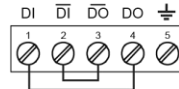

- Form C (SPDT) relays
- Two isolated supplies available even on 12/24 VDC input power models
- Removable terminal blocks
- 4 relays + isolated 4-20 mA output option

Digital I/O Connections

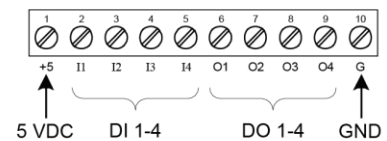

- Universal 85-265 VAC or 12/24 VDC input power
- Voltage or current inputs
- No jumpers needed for V/mA input selection
- M-Link for adding expansion modules
- Digital input (F4)

Connections for PD8-6060-6H7 & PD8-6060-7H7

The Only Explosion-Proof Dual-Input Process Meter You Will Ever Need

Front, back and in between, the PD8-6060 ProtEX-MAX explosion-proof dual-input process meter boasts specifications, features and functionality that make it the only hazardous area dual-input process meter you will ever need. The front panel push-buttons can even be operated in a hazardous area without removing the cover by using the SafeTouch through-glass feature.

The PD8-6060 has all the same features as our PD6060 1/8 DIN process meter, but it is not just a meter stuffed in an explosion-proof enclosure like many of our competitors offer. The PD8-6060 is approved as a complete product by FM and CSA and also carries IECEx approvals. Besides being suitable for hazardous areas, the number one feature that makes the PD8-6060 such a useful device is its built-in 24 VDC power supply to drive the transmitters as illustrated by the above diagram. This feature not only saves the cost of an external power supply, but also greatly simplifies wiring. In addition, there is a second 25 mA power supply provided with the 4-20 mA output option, evident also in the above diagram.

The first thing you notice about the PD8-6060 is its modern looking, rugged, die cast aluminum housing with convenient mounting flanges. Housed inside this enclosure is a

dual-line, 6-digit display with high-intensity LEDs that can be read in direct sunlight.

The PD8-6060 has two process input channels (A & B) capable of accepting current (0-20, 4-20 mA) and voltage (± 10 , 0-5, 1-5, 0-10 VDC). Each input is programmed separately, with independent input type selection and scaling. These inputs may be displayed individually as part of the customizable dual-line display, or used with a wide range of math functions. Each input has a custom unit or tag that may be displayed.

The most common use for the PD8-6060 is to display two separate inputs on the meter's dual-line display. For more demanding applications, the meter can display a mathematical function of these two inputs such as addition, difference, average, multiplication and more.

Other key features include four relays and 4-20 mA output option, advanced signal input conditioning like automatic round horizontal tank linearization, function keys, pump alternation capability, and Modbus® RTU serial communications. Finally, all these features and capabilities can easily be programmed without removing the cover using SafeTouch buttons in a hazardous area or with free MeterView Pro PC-based software in a safe area.

Easy Programming Methods

The ProtEX-MAX can be programmed in a hazardous area with the through-glass SafeTouch buttons without removing the cover, in a safe area with the front panel push buttons with the cover removed, or in a safe area with free, PC-based MeterView Pro software. MeterView Pro is resident on the ProtEX-MAX and is accessed by a provided USB cable, so it is by far the easiest way to program the ProtEX-MAX. The ProtEX-MAX can be calibrated either by applying a known signal or scaled by entering a desired value with the front panel buttons or MeterView Pro software. Most customers will use the scaling method because it is simpler and does not require a calibrated signal source. Selecting the input to be current or voltage is done with the front panel buttons or MeterView Pro software. Once programming is completed it can be locked with a password.

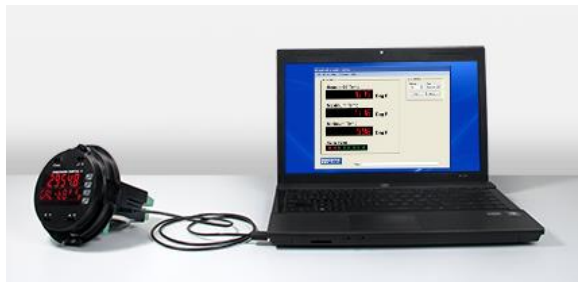

The ProtEX-MAX comes preloaded with free MeterView Pro programming software that connects and installs directly to your PC with a standard USB cable, also provided free with each instrument. This eliminates the need to insert CDs, install drivers, or download software from the internet. When you connect your ProtEX-MAX to your PC, MeterView Pro is downloaded to your PC, the software automatically selects the model you are programming, and you're ready to start programming immediately.

MeterView Pro can be used to scale both of the inputs (Channel A & Channel B) on the PD8-6060. In the example below, Channel A has nine points of linearization and Channel B has two points.

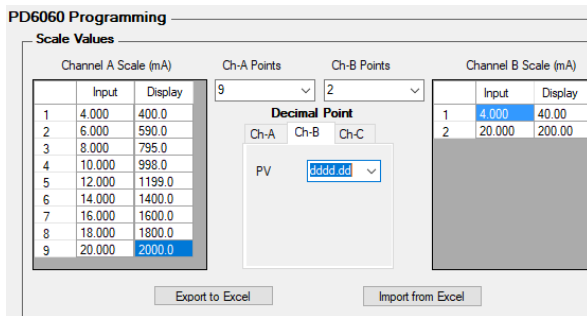

Further simplifying the programming process, the ProtEX-MAX can be powered from the USB port, so no need to apply external power while programming your meter. In addition to programming, the software will also allow you to monitor, and datalog a ProtEX-MAX using your PC. You can also generate and save programming files for later use.

Advanced Display Features

Dual-Line Makes All the Difference

The ProtEX-MAX has two red LED displays, a main display 0.60" (15 mm) high, and a second display 0.46" (12 mm) high. Each display is a full 6 digits (-99999 to 999999).

The ProtEX-MAX's dual-line display makes all the difference both when programming the instrument and when using it in the field. When programming the instrument, the dual-line display prompts for the needed information and also helps you keep track of where you are in the setup process.

Programming Assistance

The ProtEX-MAX's dual-line display makes programming the instrument much easier because the second line prompts for the needed information and also helps you keep track of where you are in the setup process.



The ProtEX-MAX is prompting for the value for Input 2 and displaying the default value of 20.00 mA. The "2" in 20.00 is brighter than the rest of the digits indicating that it is the number that will be changed by the Up arrow.



The ProtEX-MAX is now prompting for what the user wants Display 2 to be; that is the value that corresponds to 20 mA. In this case Display 2 is currently set to 95.00.

Super-Bright Display

The ProtEX-MAX comes standard with a super-bright display, with LEDs that are visible even in direct sunlight. The display also has up to eight levels of adjustable intensity for optimum visibility in any lighting condition.

Rounding for Even Steadier Display

The rounding feature is used to give the user a steadier display with fluctuating signals. It causes the display to round to the nearest value according to the rounding value selected (1, 2, 5, 10, 20, 50, or 100). For example, with a rounding value of 10, and an input of 12346, the display would indicate 12350.

Customizable Displays

The ProtEX-MAX has two red LED displays, a main display 0.60" (15 mm) high, and a second display 0.46" (12 mm) high. Each display is a full 6 digits (-99999 to 999999).

The displays can be set up to read input channels (A or B), math function channel C, toggle between A & B, B & C, A & C, A & B & C, toggle between channels A, B, or C & units, the max/min of any of the channels, including the math channel (C), set points, gross (without tare) or net (with tare) & gross values of channel A or B, or the Modbus® input. This allows the display to be setup to display whatever variables are most valuable to the application. Here are just a few examples.

Input Channels A & B

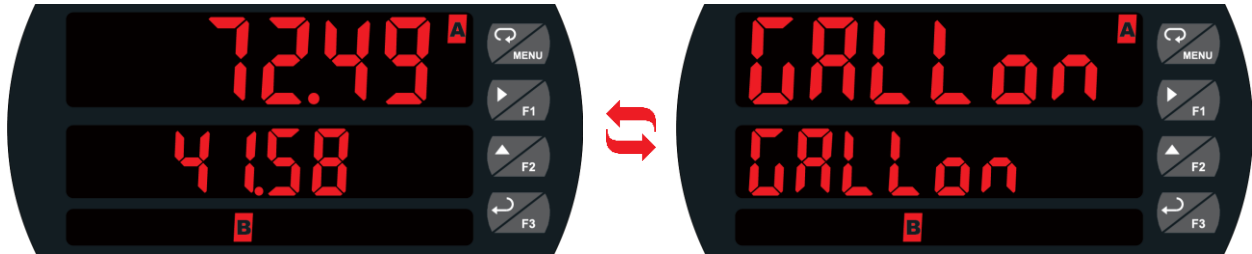

Both input channels are displayed with input A on the main display and input B on the second display as indicated by LEDs (A & B) on the display. The meter also toggles between the units for these inputs.

Math Function & Inputs A & B

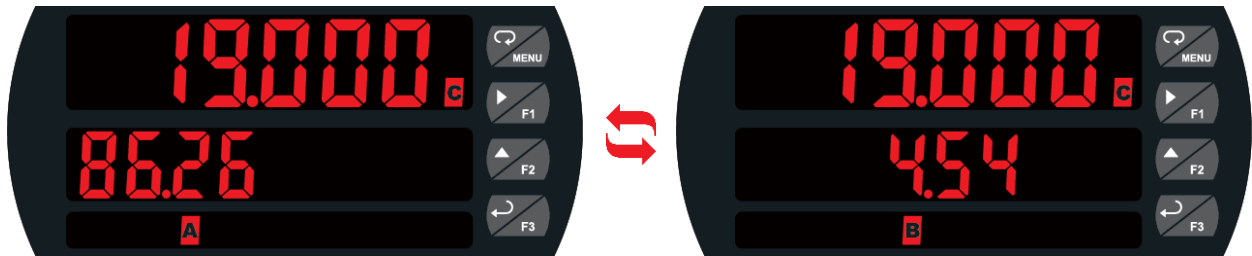

The main display shows the math function result (C); in this case Channel A divided by Channel B. The second display alternates between channels A and B, with an indicator to indicate which channel is being displayed.

Math Function & Tag



The main display shows the math function result (C) of the two input channels (A & B). The second display shows a custom label, in this case the math function used.

Physical Features

The ProtEX-MAX is designed for ease-of-use in safe and hazardous applications. The ProtEX-MAX is housed in a rugged NEMA 4X explosion-proof enclosure, can operate over a wide temperature range, includes removable screw terminal connectors, has worldwide approvals for use in hazardous areas, and features through-glass buttons for easy meter operation without the need to remove the cover. All of these features are backed by a 3-year warranty.

Super-Bright LED Display

The ProtEX-MAX features a dual-line 6-digit display with super-bright LEDs, our brightest ever. These allow the display to be read in any lighting condition, even in direct sunlight.



SafeTouch Through-Glass Buttons

The ProtEX-MAX is equipped with four sensors that operate as through-glass buttons so that it can be programmed and operated without removing the cover (and exposing the electronics) in a hazardous area. These buttons can be disabled for security by selecting the DISABLE setting on the NO-CONTACT BUTTONS switch located on the back of the electronics module, inside the enclosure.

Rugged, Heavy-Duty Enclosure

The ProtEX-MAX is housed in a rugged NEMA 4X, 7, & 9, IP68 die-cast aluminum enclosure, designed to withstand harsh environments in safe and hazardous areas over a wide temperature range.



Wide Viewing Angle

Customers can't always look at the display from straight on, so the window and display module have been optimized to provide a wide viewing angle of approximately +/- 40°; nearly twice that of the competition.



Built-In Mounting Flanges

The ProtEX-MAX is equipped with four slotted flanges for wall mounting or NPS 1½" to 2½" or DN 40 to 65 mm pipe mounting.



Flexible Mounting & Wiring

The ProtEX-MAX features four ¾" NPT threaded conduit openings so that wiring can be routed to the most convenient conduit connection(s). Two ¾" NPT metal conduit plugs with 12 mm hex key fitting come installed.



Rotatable Display

The ProtEX-MAX rotatable display, along with four available conduit connections, provide for numerous installation options. The display can be rotated in 90° increments. Rotate it 90° for horizontal mounting.



Vertical Mounting

Horizontal Mounting

Perfect & Secure Fit Every Time

The internal cast rails ensure the ProtEX-MAX assembles together perfectly, quickly and securely; and everything lines up for optimal viewing every time. There are no standoffs to worry about breaking or getting out of alignment. Two spring-loaded, self-retaining, thumbscrews make the assembly a snap, while pressing the display as close to the glass as possible to improve wide angle viewing.

Stainless Steel Tags

PDA-SSTAG is a laser etched stainless steel tag accessory for any of your Precision Digital meters. The tag features custom text for equipment identification, instruction, or whatever else is needed in your facility. Each tag comes with a stainless steel wire and lead seal for easy mounting wherever you need it.



Removable Screw Terminals

Industrial applications require screw terminal connections for easy field wiring and the ProtEX-MAX goes one step further in convenience by making them removable also.



Note: The above photograph is representative of the back of the PD8-6060 in every regard except for the signal input connector. See Figure 5 on page 28 for actual input signal connections.

USB Port MeterView Pro



Hazardous Area Approvals

The ProtEX-MAX's approvals allow it to be used in hazardous areas around the world. These include: FM Approved as Explosion-Proof / Dust-Ignition-Proof / Flame-Proof, CSA Certified as Explosion-Proof / Dust-Ignition-Proof, and ATEX and IECEx Certified as Flame-Proof.

Wide Operating Temperature Range

The ProtEX-MAX can operate from -40 to 60°C (-40 to 140°F) meaning it can be installed in a wide variety of indoor and outdoor industrial applications. And over this range, the ProtEX-MAX will drift no more than 0.005% of calibrated span/°C max from 0 to 65°C ambient and 0.01% of calibrated span/°C max from -40 to 0°C ambient.

Transmitter Power Supplies

Meter Powers Transmitters

One of the most useful standard features of the PD8-6060 is its built-in isolated, 24 V @ 25 mA power supply to power the transmitters. This feature saves money by eliminating an external power supply and also simplifies wiring by reducing the number of devices in the loop. It can be configured for 5, 10, or 24 V (default) by means of a simple internal jumper. This power supply is even available on meters that are powered from DC power (24 V @ 25 mA). To use an external power supply instead of the internal power supply, simply make connections to different terminals on the ProtEX-MAX.

The following diagram illustrates how to wire the ProtEX-MAX so it will power the transmitters:

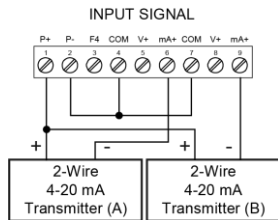

Meter Powers 4-20 mA Output

Not only can the ProtEX-MAX power the 4-20 mA input signal, but an additional power supply of 24 V @ 25 mA is provided with the 4-20 mA output option to power the 4-20 mA output.

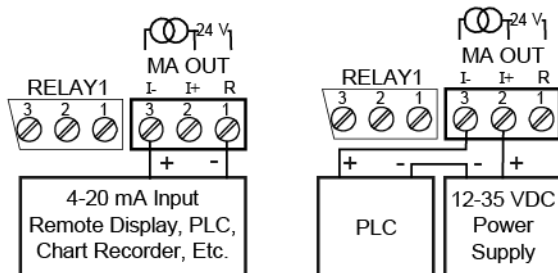

Fuse Prevents Current Overload

Another very useful aspect of the ProtEX-MAX is that the current input is protected against current overload by a resettable fuse. The fuse limits the current to a safe level when it detects a fault condition, and automatically resets itself when the fault condition is removed.

Input Signal Conditioning

Non-linear input signals (i.e. weirs & flumes, differential pressure, round horizontal tanks, etc.) can be linearized with the ProtEX-MAX's simple to use built-in signal input conditioning functions. These include square-root extractor, exponential linearizer, round horizontal tank linearizer, and user-customizable 32-point linearizer.

Round Horizontal Tank Linearization

This function automatically calculates the volume in a round horizontal tank with flat ends.

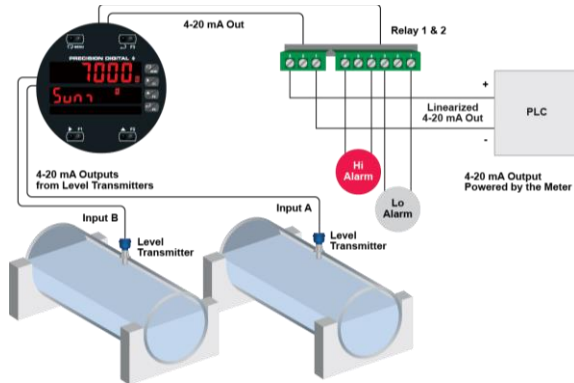

The PD8-6060 is powering and displaying the output from two level sensors in two different tanks. The meter is currently displaying the sum of these two tanks but is also programmed to toggle between the sum and the actual volume in both tanks.

Using MV Pro for RHT Function

MeterView Pro can be used to easily program the meter to display volume in a round horizontal tank. The user merely selects the RHT Signal Input Conditioning function from the drop-down menu and enters the diameter and length of the tank and the meter does the rest!

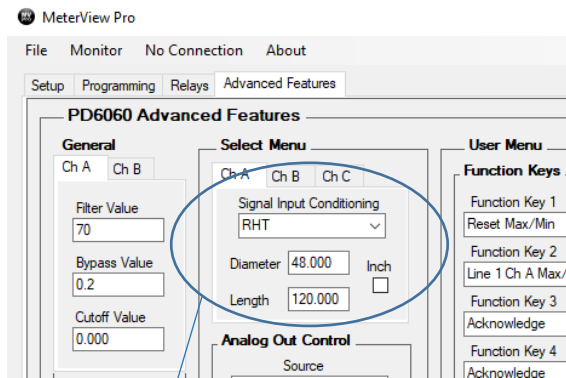

Round Horizontal Tank Function

Square Root Linearization

The square root function is used to calculate flow measured with a differential pressure transmitter. The flow rate is proportional to the square root of the differential pressure. Scale the meter so that the low input signal (e.g. 4 mA) is equal to zero flow and the high input signal (e.g. 20 mA) is equal to the maximum flow.

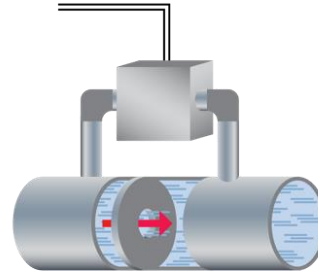

Open-Channel Flow Calculated Using Exponential Signal Input Conditioner

The programmable exponent can be used to linearize the signal from level transmitters in open-channel flow applications using weirs and flumes.

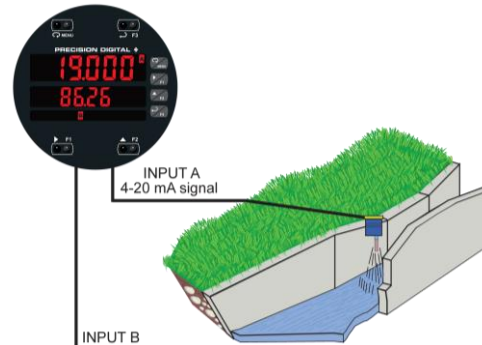

Multi-Point Linearization

The most common way to linearize a non-linear signal is to break it up into smaller ranges that are more linear than the overall range. The PD8-6060 is available with up to 32 points of linearization for both inputs. The linearization data can be imported from an Excel spreadsheet or can be exported from MeterView Pro to an Excel spreadsheet.

Using MV Pro for Multi-Point Linearization

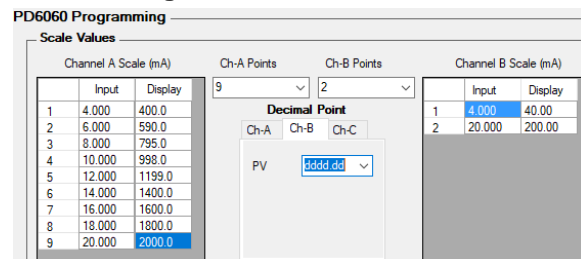

The above graphic illustrates Channel A input being linearized with nine scaling points and Channel B using the more standard two-point scaling method.

Explosion-Proof Dual-Pump Alternation in Two Tanks

The ProtEX-MAX can be used as an explosion-proof pump controller when combined with a continuous level transmitter. Since the PD8-6060 accepts two 4-20 mA inputs (from two different level transmitters) and can be equipped with four relays, it could be used to control and alternate two pumps in two different tanks as well as provide the 24 V to power the transmitters. The illustration below shows how the relays control both the main and backup pumps to maintain the levels in tanks 1 and 2.

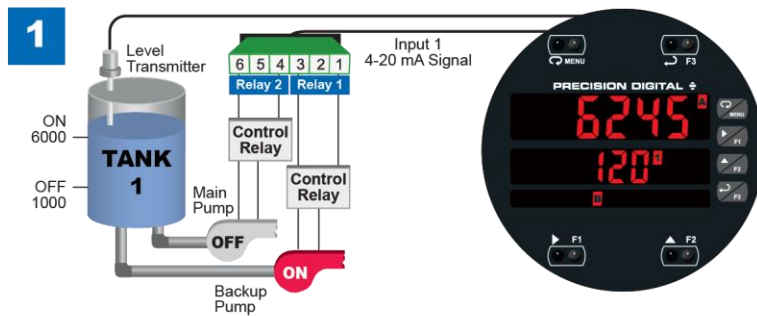
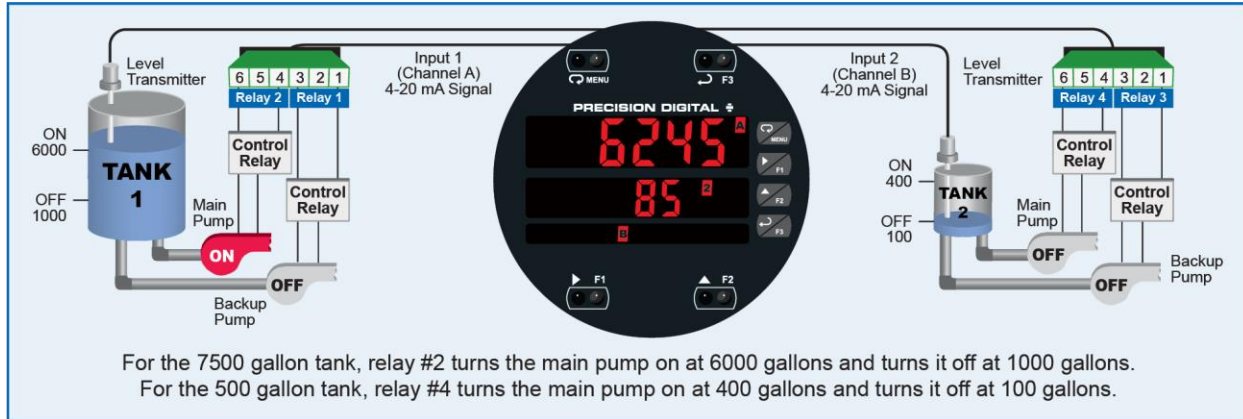

With the Pump Alternation feature activated, the next time the level reaches 6000 gallons, relay #1 transfers and starts the backup pump.

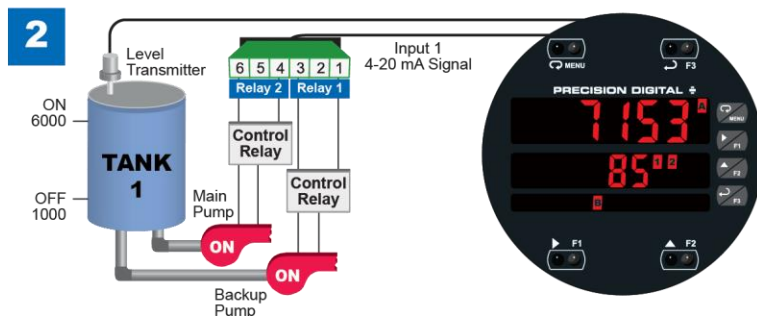

If the backup pump is not able to keep up, and the level reaches 7000 gallons, relay #2 transfers and starts the main pump as well.

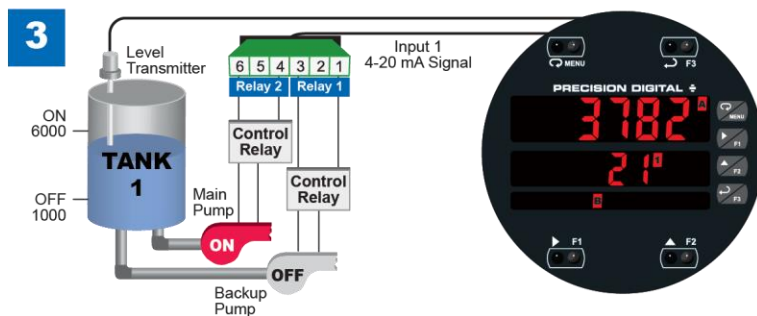

At 4000 gallons, relay 1 turns off and the system returns to normal pump alternation control.



Learn how to use the ProVu (ProtEX-MAX) meter as an explosion-proof pump controller. See how the four relays can be used to alternate two pumps and provide high and low alarms. predig.com/videos/PumpControl

Useful Tools

PD9501 Multi-Function Calibrator



This [PD9501](#) Multi-Function Calibrator has a variety of signal measurement and output functions, including voltage, current, thermocouple, and RTD.

PD9502 Low-Cost Signal Generator



The [PD9502](#) is a low-cost, compact, simple to use 4-20 mA or 0-10 VDC signal generator. It can easily be set for 0-20 mA, 4-20 mA, 0-10 V or 2-10 V ranges. Signal adjustment is made with a one-turn knob. A 15-27 VDC wall plug is provided with the instrument. Optional USB power bank is available.

Specifications

Except where noted all specifications apply to operation at +25°C.

General

Display	Display Line 1: 0.60" (15 mm) high, red LEDs Display Line 2: 0.46" (12 mm) high, red LEDs 6 digits each (-99999 to 999999), with lead zero blanking
Display Intensity	Eight user selectable intensity levels. Default intensity is six.
Display Update Rate	5/second (200 ms)
LED Status Indicators	See <i>LED Status Indicators</i> on page 33 for details.
Overrange	Display flashes 999999
Underrange	Display flashes -99999
Display Assignment	Display Line 1: Channels A (Ch-A), B (Ch-B), or C (Ch-C), toggle between (Ch-A & Ch-B, Ch-A & Ch-C, Ch-B & Ch-C, and Ch-A, Ch-B, & Ch-C), toggle between channel & units, channel gross weight, toggle net and gross weights, set points, max & min values, or Modbus® input Display Line 2: Same as Display Line 1; plus units, tag or turned off
Programming Methods	Four SafeTouch through-glass buttons when cover is installed. Mechanical buttons can be used with the cover removed. Free PC-based USB MeterView Pro programming software.
Noise Filter	Programmable from 2 to 199 (0 will disable filter)
Filter Bypass	Programmable from 0.1 to 99.9% of calibrated span
Recalibration	All ranges are calibrated at the factory. Recalibration is recommended at least every 12 months.
Max/Min Display	Max/min readings reached by the process are stored until reset by the user or until power to the meter is turned off.
Rounding	Select 1, 2, 5, 10, 20, 50, or 100 (e.g. rounding = 10, value = 123.45, display = 123.50).
Tare	Tare function zeros out the meter to remove the weight of a container. Tare function can be assigned to a function key, F4 terminal, or a digital input.
Password	Three programmable passwords restrict modification of programmed settings. Pass 1: Allows use of function keys and digital inputs Pass 2: Allows use of function keys, digital inputs and editing set/reset points Pass 3: Restricts all programming, function keys, and digital inputs

Non-Volatile Memory	All programmed settings are stored in non-volatile memory for a minimum of ten years if power is lost.
Power Options	85-265 VAC 50/60 Hz; 90-265 VDC, 20 W max; 12-24 VDC, 12-24 VAC, 15 W max. Powered over USB for configuration only.
Fuse	Required external fuse: UL Recognized, 5 A max, slow blow; up to 6 meters may share one 5 A fuse
Normal Mode Rejection	Greater than 60 dB at 50/60 Hz
Isolation	4 kV input/output-to-power line 500 V input-to-output or output-to-P+ supply
Overvoltage Category	Installation Overvoltage Category II: Local level with smaller transient overvoltages than Installation Overvoltage Category III
Environmental	T6 Class operating temperature range Ta = -40 to 60°C T5 Class operating temperature range Ta = -40 to 65°C Storage temperature range: -40 to 85°C (-40 to 185°F) Relative humidity: 0 to 90% non-condensing
Max Power Dissipation	Maximum power dissipation limited to 15.1 W
Connections	Power, signal, relays, mA out: Removable screw terminal blocks accept 12 to 22 AWG wire RS-485: Removable screw terminal block accepts 16 to 30 AWG wire Digital I/O: Removable screw terminal blocks accept 16 to 30 AWG wire
Enclosure	Explosion-proof die cast aluminum with glass window, corrosion resistant epoxy coating, color: blue NEMA 4X, 7, & 9, IP68 Default conduit connections: Four ¾" NPT threaded conduit openings and two ¼" NPT metal conduit plugs with 12 mm hex key fitting installed. Additional conduit opening configurations may be available; verify quantity and sizes on specific device labeling during installation.
Mounting	Wall Mounting: Four (4) mounting holes provided for mounting meter to wall. See <i>Wall Mounting Instructions</i> on page 24 for additional details. Pipe Mounting: Optional pipe mounting kit (PDA6848) allows for pipe mounting. Sold separately. See <i>Pipe Mounting Instructions</i> on page 25 for additional details.
Tightening Torque	Power, signal, relays, mA out terminals: 5 lb-in (0.56 Nm) Digital I/O and RS-485: 2.2 lb-in (0.25 Nm)
Overall Dimensions	6.42" x 7.97" x 8.47" (W x H x D) (163 mm x 202 mm x 215 mm)
Weight	16.0 lbs (7.26 kg)
Warranty	3 years parts & labor. See Warranty Information and Terms & Conditions on www.predig.com for complete details.

Dual Process Inputs

Two Inputs	Two non-isolated inputs, independent, field selectable: 0-20 mA, 4-20 mA, ±10 V (0-5 V, 1-5 V, 0-10 V), Modbus® PV (Slave)		
Isolated Transmitter Power Supply	Terminals P+ & P-: 24 VDC ± 10%. Isolated from the input at >500 V. Jumper selectable for 24, 10, or 5 VDC supply (internal jumper J4). All models transmitter supply rated @ 25mA max. Refer to <i>Transmitter Supply Voltage Selection (P+, P-)</i> on page 27.		
Channels	Channel A, Channel B, Channel C (Math channel)		
Programmable Constants	Constant P (Adder): -99.999 to 999.999, default: 0.000 Constant F (Factor): 0.001 to 999.999, default: 1.000		
Math Functions	Name	Function	Setting
	Addition	$(A+B+P)*F$	5 u n r
	Difference	$(A-B+P)*F$	d i F
	Absolute diff.	$((Abs(A-B))+P)*F$	d i F R b 5
	Average	$((A+B)/2+P)*F$	R u ũ
	Multiplication	$(A*B+P)*F$	n r u L t i
	Division	$(A/B+P)*F$	d i ũ i d E
	Max of A or B	$((AB-Hi)+P)*F$	H i - R b
	Min of A or B	$((AB-Lo)+P)*F$	L o - R b
	Draw	$(A/B-1)*F$	d r R u j
	Weighted avg.	$((B-A)*F)+A$	u j R u ũ
Ratio	$(A/B)*F$	r R t i o	
Ratio 2	$((B-A)/A+P)*F$	r R t i o 2	
Concentration	$(A/(A+B))*F$	C o n c E n	
	<i>Note: The F constant can be any value from 0.001 to 999.999. If the value is less than 1, it will have the same effect as a divider. For example, the average could also be derived by using $(A+B)*F$, where $F = 0.500$.</i>		
Sequence of Operations for Input Programming	<ol style="list-style-type: none"> 1. Select Input for A and B 2. Set up the engineering units for A, B, and C 3. Set up decimal point for A, B, and C 4. Program A & B 5. Set up the displays for A, B, or C 6. Select the transfer function for A & B (e.g. Linear) 7. Select Math function for Channel C 8. Program constants for Factor (F) and Adder (P) 9. Program cutoff values for A and B 		
Accuracy	±0.03% of calibrated span ±1 count, square root & programmable exponent accuracy range: 10-100% of calibrated span		
Temperature Drift	0.005% of calibrated span/°C max from 0 to 65°C ambient, 0.01% of calibrated span/°C max from -40 to 0°C ambient		
Input Signal Conditioning	Linear, square root, programmable exponent, or round horizontal tank volume calculation		
Multi-Point Linearization	2 to 32 points for channels A and B		
Programmable Exponent	User selectable from 1.0001 to 2.9999 for open channel flow		

Low-Flow Cutoff	0.1 to 999,999 (0 disables cutoff function). Point below at which display always shows zero.	
Decimal Point	Up to five decimal places or none: d d d d d d, d d d d d, d d d d, d d d, d d, d d, or d d d d d d	
Calibration Range	Input Range	Minimum Span Input 1 & 2
	4-20 mA	0.15 mA
	±10 V	0.10 V
	An error message will appear if the input 1 and input 2 signals are too close together.	
Input Impedance	Voltage ranges: greater than 500 kΩ Current ranges: 50 - 100 Ω (depending on internal resettable fuse impedance)	
Input Overload	Current input protected by an internal resettable fuse, 30 VDC max. Fuse resets automatically after fault is removed.	
HART Incompatible	<p>The meter can support ONLY one HART loop on either of the inputs. A signal isolator is required if two HART loops are being connected.</p> <p>Under the described conditions, the meter does not interfere with existing HART communications; it displays the 4-20 mA primary variable and it allows the HART communications to pass through without interruption. The meter is not affected if a HART communicator is connected to the loop. The meter does not display secondary HART variables.</p>	

Relays

Rating	4 SPDT (Form C) internal and rated 3 A @ 30 VDC and 125/250 VAC resistive load; 1/14 HP (≈ 50 W) @ 125/250 VAC for inductive loads	
Noise Suppression	Noise suppression is recommended for each relay contact switching inductive loads. See <i>Switching Inductive Loads</i> on page 32 for details.	
Relay Assignment	Relays may be assigned to Ch-A, Ch-B, Ch-C, or Modbus® input	
Deadband	0-100% of span, user programmable	
High or Low Alarm	User may program any alarm for high or low trip point. Unused alarm LEDs and relays may be disabled (turn off).	
Relay Operation	<ul style="list-style-type: none"> • Automatic (non-latching) and/or manual reset • Latching (requires manual acknowledge) with or without clear • Pump alternation control (2-4 relays) • Sampling (based on set point and time) • Off (disable unused relays and enable Interlock feature) • Manual on/off control mode 	
Relay Reset (Acknowledge)	User selectable via front panel button, F4 digital input, external contact closure on digital inputs, or through serial communications	
Time Delay	0 to 999.9 seconds, on & off relay time delays. Programmable and independent for each relay	

Fail-Safe Operation	Programmable and independent for each relay. <i>Note: Relay coil is energized in non-alarm condition. In case of power failure, relay will go to alarm state.</i>
Auto Initialization	When power is applied to the meter, relays will reflect the state of the input to the meter.

USB Connection

Function	Programming only
Compatibility	USB 2.0 Standard, Compliant
Connector Type	Micro-B receptacle
Cable	USB A Male to Micro-B Cable
Driver	Microsoft® Windows® XP/Vista/7/8/10
Power	USB port provides power to the meter. DO NOT apply AC or DC power to the meter while the USB port is in use.

Isolated 4-20 mA Transmitter Output

Output Source	Process channel A, B, or C, max or min for channel A, B, or highest or lowest of A and B, set points 1-4, Modbus® input, or manual control mode									
Scaling Range	1.000 to 23.000 mA for any display range									
Calibration	Factory calibrated: 4.000 to 20.000 = 4-20 mA output									
Analog Out Programming	23.000 mA maximum for all parameters: Overrange, underrange, max, min, and break									
Accuracy	± 0.1% of span ± 0.004 mA									
Temperature Drift	0.4 µA/°C max from 0 to 65°C ambient, 0.8 µA/°C max from -40 to 0°C ambient <i>Note: Analog output drift is separate from input drift.</i>									
Isolated Transmitter Power Supply	Terminals I+ & R: 24 VDC ± 10%. Isolated from the input at >500 V. May be used to power the 4-20 mA output or other devices. All models @ 25 mA max.									
External Loop Power Supply	35 VDC maximum									
Output Loop Resistance	<table border="1"> <thead> <tr> <th>Power supply</th> <th>Minimum</th> <th>Maximum</th> </tr> </thead> <tbody> <tr> <td>24 VDC</td> <td>10 Ω</td> <td>700 Ω</td> </tr> <tr> <td>35 VDC (external)</td> <td>100 Ω</td> <td>1200 Ω</td> </tr> </tbody> </table>	Power supply	Minimum	Maximum	24 VDC	10 Ω	700 Ω	35 VDC (external)	100 Ω	1200 Ω
Power supply	Minimum	Maximum								
24 VDC	10 Ω	700 Ω								
35 VDC (external)	100 Ω	1200 Ω								

RS-485 Serial Communications

Compatibility	EIA-485
Connectors	Removable screw terminal connector
Max Distance	3,937' (1,200 m) max
Status Indication	Separate LEDs for METER LINK, Transmit (TX), and Receive (RX)

Modbus® RTU Serial Communications

Slave Id	1 – 247 (Meter address)
Baud Rate	300 – 19,200 bps
Transmit Time Delay	Programmable between 0 and 199 ms
Data	8 bit (1 start bit, 1 or 2 stop bits)
Parity	Even, Odd, or None with 1 or 2 stop bits
Byte-To-Byte Timeout	0.01 – 2.54 second
Turn Around Delay	Less than 2 ms (fixed)

Note: Refer to the Helios Modbus® Register Tables located at www.predig.com for details.

Digital Input (F4)

Function	Remote operation of front-panel buttons, acknowledge/reset relays, reset max/min values. See <i>Function Keys & Digital I/O Available Settings</i> on page 58 for a complete list of capabilities.
Contacts	3.3 VDC on contact. Connect normally open contacts across F4 to COM
Logic Levels	Logic High: 3 to 5 VDC Logic Low: 0 to 1.25 VDC

Digital Inputs & Outputs

Function	Terminals provided for remote operation of all four programming / operation buttons. Other uses include acknowledge/reset relays and reset max/min values. See <i>Function Keys & Digital I/O Available Settings</i> on page 58 for a complete list of capabilities.
Channels	4 digital inputs & 4 digital outputs
Digital Input Logic High	3 to 5 VDC
Digital Input Logic Low	0 to 1.25 VDC
Digital Output Logic High	3.1 to 3.3 VDC
Digital Output Logic Low	0 to 0.4 VDC
Source Current	10 mA maximum output current
Sink Current	1.5 mA minimum input current
+5 V Terminal	To be used as pull-up for digital inputs only. Connect normally open push buttons across +5 V & DI 1-4.

⚠ WARNING

- **DO NOT** use +5 V terminal to power external devices.

MeterView Pro Software

Availability	Download directly from meter or from www.prediq.com/download_software
System Requirements	Microsoft® Windows® XP/Vista/7/8/10
Communications	USB 2.0 (for programming only) (Standard USB A to USB Type B) RS-485 to USB converter (programming, monitoring, and data logging)
Configuration	Configure meters one at a time
Power	USB port provides power to the meter. DO NOT apply AC or DC power to the meter while the USB port is in use.

Compliance Information

Electromagnetic Compatibility

Emissions	EN 55022 Class A ITE emissions requirements
Radiated Emissions	Class A
AC Mains Conducted Emissions	Class A
Immunity	EN 61326-1 Measurement, control, and laboratory equipment EN 61000-6-2 EMC heavy industrial generic immunity standard
RFI - Amplitude Modulated	80 -1000 MHz 10 V/m 80% AM (1 kHz) 1.4 - 2.0 GHz 3 V/m 80% AM (1 kHz) 2.0 - 2.7 GHz 1 V/m 80% AM (1 kHz)
Electrical Fast Transients	±2kV AC mains, ±1kV other
Electrostatic Discharge	±4kV contact, ±8kV air
RFI - Conducted	10V, 0.15-80 MHz, 1kHz 80% AM
AC Surge	±2kV Common, ±1kV Differential
Surge	1KV (CM)
Power-Frequency Magnetic Field	30 A/m 70%V for 0.5 period
Voltage Dips	40%V for 5 & 50 periods 70%V for 25 periods
Voltage Interruptions	<5%V for 250 periods

Note:

Testing was conducted on meters with cable shields grounded at the point of entry representing installations designed to optimize EMC performance.

Product Ratings and Approvals

FM	Enclosure: Type 4X; IP66 Class I, Division 1, Groups B, C, D Class II, Division 1, Groups E, F, G Class III, Division 1, T5/T6 Class I, Zone 1, AEx d, IIC Gb T5/T6 Zone 21, AEx tb IIIC T90°C; Ta -40°C to +65°C T6 Ta = -40°C to +60°C; T5 Ta = -40°C to +65°C Certificate Number: 3047283
CSA	Class I, Division 1, Groups B, C, D Class II, Division 1, Groups E, F, G Class III, Division 1 Class I Zone 1 Ex d IIC Zone 21 Ex tb IIIC T90°C -40°C < Tamb. < +60° C; Temperature Code T6 -40°C < Tamb. < +65° C; Temperature Code T5 Enclosure Type 4X & IP66 Certificate Number: 2531731
ATEX 	II 2 G D Ex d IIC T* Gb Ex tb IIIC T90°C Db IP68 Ta = -40°C to +*°C *T6 = -40°C to +60°C *T5 = -40°C to +65°C Certificate number: Sira 12ATEX1182
IECEX	Ex d IIC T* Gb Ex tb IIIC T90°C Db IP68 Ta = -40°C to +*°C *T6 = -40°C to +60°C *T5 = -40°C to +65°C Certificate Number: IECEX SIR 12.0073

Special Conditions for Safe Use:

Use suitably certified and dimensioned cable entry device and/or plug. The equipment shall be installed such that the supply cable is protected from mechanical damage. The cable shall not be subjected to tension or torque. If the cable is to be terminated within an explosive atmosphere, then appropriate protection of the free end of the cable shall be provided. Cable must be suitable for 90°C.

Year of Construction

This information is contained within the serial number with the first four digits representing the year and month in the YYMM format.

For European Community: The ProtEX-MAX must be installed in accordance with the ATEX directive 94/9/EC, and the product certificate Sira 12ATEX1182.

EU Declaration of Conformity

EU Declaration of Conformity is available in the Documentation CD provided with the product under the **EU DoC** menu.

Safety Information

⚠ CAUTION

- Read complete instructions prior to installation and operation of the meter.

⚠ WARNINGS

- Risk of electric shock or personal injury.
- Hazardous voltages exist within enclosure. Installation and service should be performed only by trained service personnel.

Installation

Install in accordance with applicable local and national regulations (e.g. NEC).

For Installation in USA

The ProtEX-MAX must be installed in accordance with the National Electrical Code (NEC) NFPA 70.

For Installation in Canada

The ProtEX-MAX must be installed in accordance with the Canadian Electrical Code CSA 22.1. All power supplies below 36 V and input circuits must be derived from a CSA Approved Class 2 source.

For European Community

The ProtEX-MAX must be installed in accordance with the ATEX directive 94/9/EC and the product certificate Sira 12ATEX1182.

⚠ WARNINGS

- Disconnect from supply before opening enclosure.
- Keep cover tight while circuits are live.
- Conduit seals must be installed within 18" (450mm) of the enclosure or within 2" (50mm) for Zone installations.

Wiring connectors are accessed by opening the enclosure. To access electrical connectors, remove the 2 captive screws and then remove the electronics module. Connectors are on the rear of the electronics module.

Unpacking

Remove the meter from box. Inspect the packaging and contents for damage. Report damages, if any, to the carrier.

If any part is missing or the meter malfunctions, please contact your supplier or the factory for assistance.

Pre-Installed Conduit Plugs

The ProtEX-MAX is supplied with two pre-installed conduit plugs for installations that do not require the use of all four conduit entries. The conduit/stopping plugs include an internal hexagonal socket recess for removal. The conduit plugs and their factory installation are included in all hazardous area approvals of this product.

⚠ WARNING

- In hazardous areas, conduit and conduit/stopping plugs require the application of non-setting (solvent free) thread sealant. It is critical that all relevant hazardous area guidelines be followed for the installation or replacement of conduit or plugs.

Cover Jam Screw



The cover jam screw should be properly installed once the meter has been wired and tested in a safe environment. The cover jam screw is intended to prevent the removal of the meter cover in a hazardous environment without the use of tools. Using a M2 hex wrench, turn the screw clockwise until the screw contacts the meter. Turn the screw an additional 1/4 to 1/2 turn to secure the cover.

⚠ CAUTION

- Excess torque may damage the threads and/or wrench.

Mounting

The ProtEX-MAX has four slotted mounting flanges that may be used for pipe mounting or wall mounting.

Refer to *Figure 1* and *Figure 2* below.

⚠ WARNING

- Do not attempt to loosen or remove flange bolts while the meter is in service.

Mounting Dimensions

All units: inches (mm)

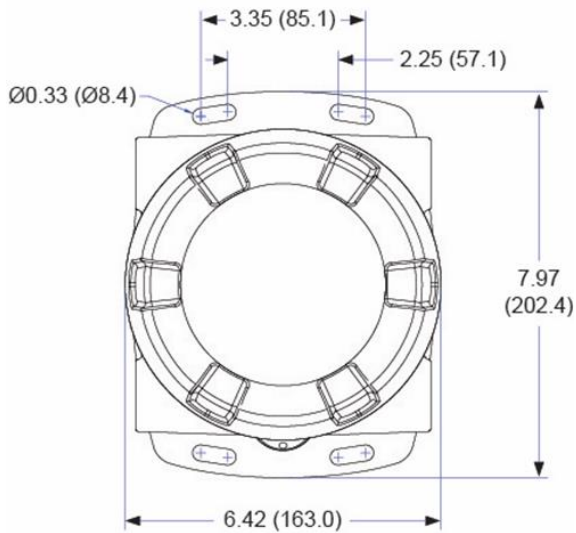

Figure 1. Enclosure Dimensions – Front View

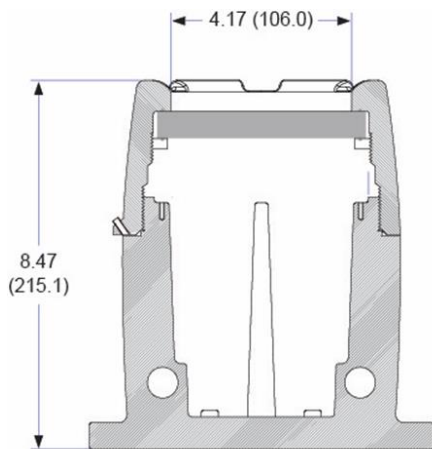

Figure 2. Enclosure Dimensions – Side Cross Section View

Wall Mounting Instructions

The meter can be mounted to any wall or flat surface using the four provided mounting holes located in the cast-in flanges. In addition, the internal electronic assembly can be rotated to allow the enclosure to be mounted in any position. To mount the meter to a wall, follow these instructions:

- Prepare a section of wall approximately 7" x 8.5" (178 mm x 216 mm) for meter mounting by marking with a pencil the mounting holes (shown in *Figure 1*) on the wall.
- Select the appropriate mounting screws for the mounting surface to be used. The mounting holes diameter is shown on *Figure 1*.

Note: Mounting screws are not included.
- Using a drill bit slightly smaller than the girth of the mounting screws, pre-drill holes at the mounting locations previously marked.
- Insert mounting screws into the four mounting holes and screw them into the pre-drilled holes.

ENCLOSURE
CAD
DIMENSIONAL DRAWINGS

Download free 3-D CAD files of these instruments to simplify your drawings!

predig.com/documentation-cad

Pipe Mounting Instructions



Vertical Pipe Mounting

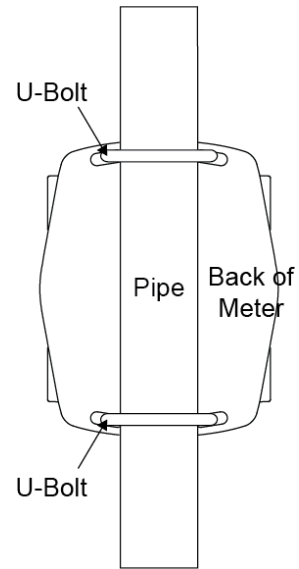

The meter can also be mounted to a pipe using an optional U-Bolt kit. This kit includes two U-bolts, the necessary hardware, and is available in zinc plated steel ([PDA6848](#)) and 316 stainless steel ([PDA6848-SS](#))

Horizontal Pipe Mounting

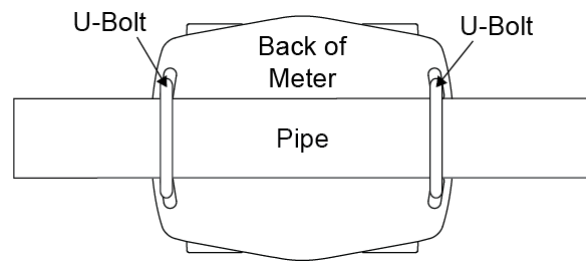

To mount the meter using a U-Bolt kit, follow these instructions:

- Orient the groove on the back of the instrument with the pipe and secure it to the pipe with the two U-bolts and hardware provided.



Installation Overview

We recommend the following sequence for getting the meter into service:

1. **DO NOT** apply AC or DC power to the meter.
2. Connect the meter to the PC with the USB cable provided. **DO NOT** use a different USB cable.
3. If MeterView Pro (MVPro) is already installed in your computer, then the program will launch automatically in most systems. If the program does not start automatically, double-click on the MVPro icon.
4. If MVPro is not installed, follow the instructions provided below.
5. Use MVPro to configure the meter for your application.
6. Disconnect the USB cable from the meter.
7. Apply power and signal and check operation of the meter.
8. Install the meter and put into service.
9. Make any programming adjustments using the programming buttons.

MeterView Pro Software

The easiest and quickest way to program your ProtEX-MAX meter is to use the FREE MeterView Pro programming software. This software is loaded into the meter and connects and installs directly to your PC with the USB cable provided. **DO NOT** use a different USB cable. We recommend that the first thing you do after taking the meter out of the box is connect the ProtEX-MAX to your PC with the provided USB cable. **DO NOT** apply AC or DC power to the meter while your PC is connected to the meter as it will disrupt the USB connection. It is not necessary to apply an input signal.

MeterView Pro programming software is intuitive, and most customers can get their meter programmed as they like without even looking in the manual.

Watch Meterview Pro Software Video at www.prediq.com/meterviewpro

MeterView Pro Installation

1. Connect one end of the provided USB cable to the meter and the other end to the computer. The computer will automatically install the driver software it needs to talk to the meter. Follow the on-screen instructions and allow sufficient time for the process to complete. This can take a few minutes. If the process is interrupted, then it could leave the system in an unstable condition.

⚠ WARNINGS

- Only one meter may be connected at a time. Attaching multiple meters will cause a conflict with the meter software.
- **DO NOT** apply AC or DC power to the meter when using the USB connection.
- The meter should only be connected to a computer while it is located in a safe area.

2. Once the driver is installed, an AutoPlay dialog should appear for the drive "MAINSTAL." Click "Open folder to view files."

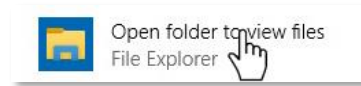

If the computer does not display an AutoPlay dialog for the drive "MAINSTAL," you should open My Computer and double-click on the drive labeled "MAINSTAL."

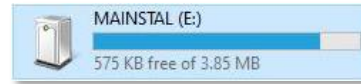

3. Double-click on the file named "MAStart." The program will open a few windows and install two programs on your computer. Simply follow the on-screen instructions until you see one of the dialogs below. If you receive a "User Account Control" warning, click "Yes."

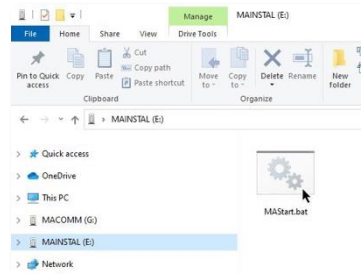

4. If there is an update available, click the "Update" button to install the new version. Otherwise, click "Configure" to begin programming your meter.

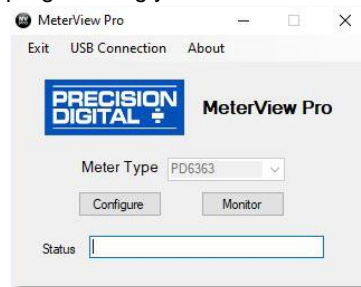

Note: If you decide to update your MeterView Pro software, once the installation has completed, you will be asked if you want to update the setup files located on the meter itself. This way, you will always have the most current version on the meter for future installs.

⚠ WARNING

- **DO NOT** unplug the meter while the new installation files are being written to it. The meter will display μA to E during the process and you will receive an on-screen notification once the process is complete.

Transmitter Supply Voltage Selection (P+, P-)

All meters, including models equipped with the 12-24 VDC power option, are shipped from the factory configured to provide 24 VDC power for the transmitter or sensor.

If the transmitter requires 5 or 10 VDC excitation, the internal jumper J4 must be configured accordingly.

To access the voltage selection jumper:

1. Remove all the wiring connectors.
2. Unscrew the back cover.
3. Slide out the back cover by about 1 inch.
4. Configure the J4 jumper, located behind the input signal connector, for the desired excitation voltage as shown.

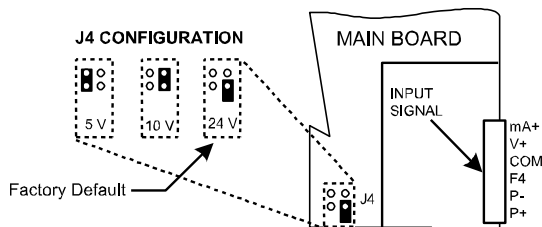

Figure 3. Transmitter Supply Voltage Selection

Connections

All connections are made to removable screw terminal connectors located at the rear of the meter.

CAUTION

- Use copper wire with 60°C or 60/75°C insulation for all line voltage connections. Observe all safety regulations. Electrical wiring should be performed in accordance with all applicable national, state, and local codes to prevent damage to the meter and ensure personnel safety.

WARNINGS

- Observe all safety regulations. Electrical wiring should be performed in accordance with all agency requirements and applicable national, state, and local codes to prevent damage to the meter and ensure personnel safety.
- Static electricity can damage sensitive components.
- Observe safe handling precautions for static-sensitive components.
- Use proper grounding procedures/codes.
- If the instrument is installed in a high voltage environment and a fault or installation error occurs, high voltage may be present on any lead or terminal.
- Follow all fusing and wiring precautions requirements for the instrument integrated to the PD8 Series model number being connected.

To access the connectors, remove the enclosure cover and unscrew the two captive screws that fasten the electronics module. Signal connections are made to de-pluggable connectors on the back of the electronics module.

Some connectors may be provided already connected. These connections are required for proper operation of the ProtEX-MAX, and should not be removed unless instructed to by this manual.

Wires marked as being used for testing purposes should be removed.

Grounding connections are made to the two ground screws provided on the base – one internal and one external.

After all connections have been completed and verified, apply power to the unit.

Required & Factory Wired Connection

The ProtEX-MAX comes with a pre-wired connection. This connection is detailed below and must be maintained in order for the instrument to function properly.

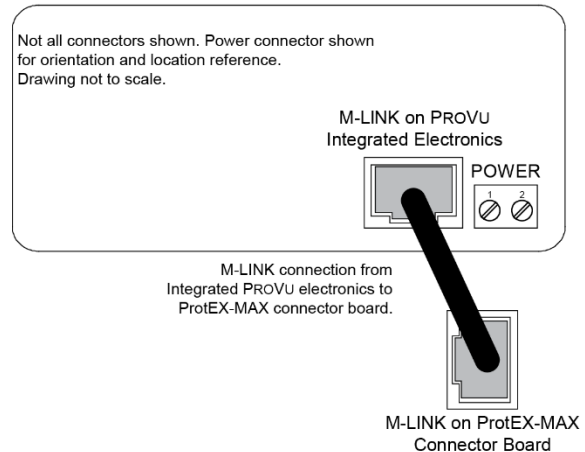
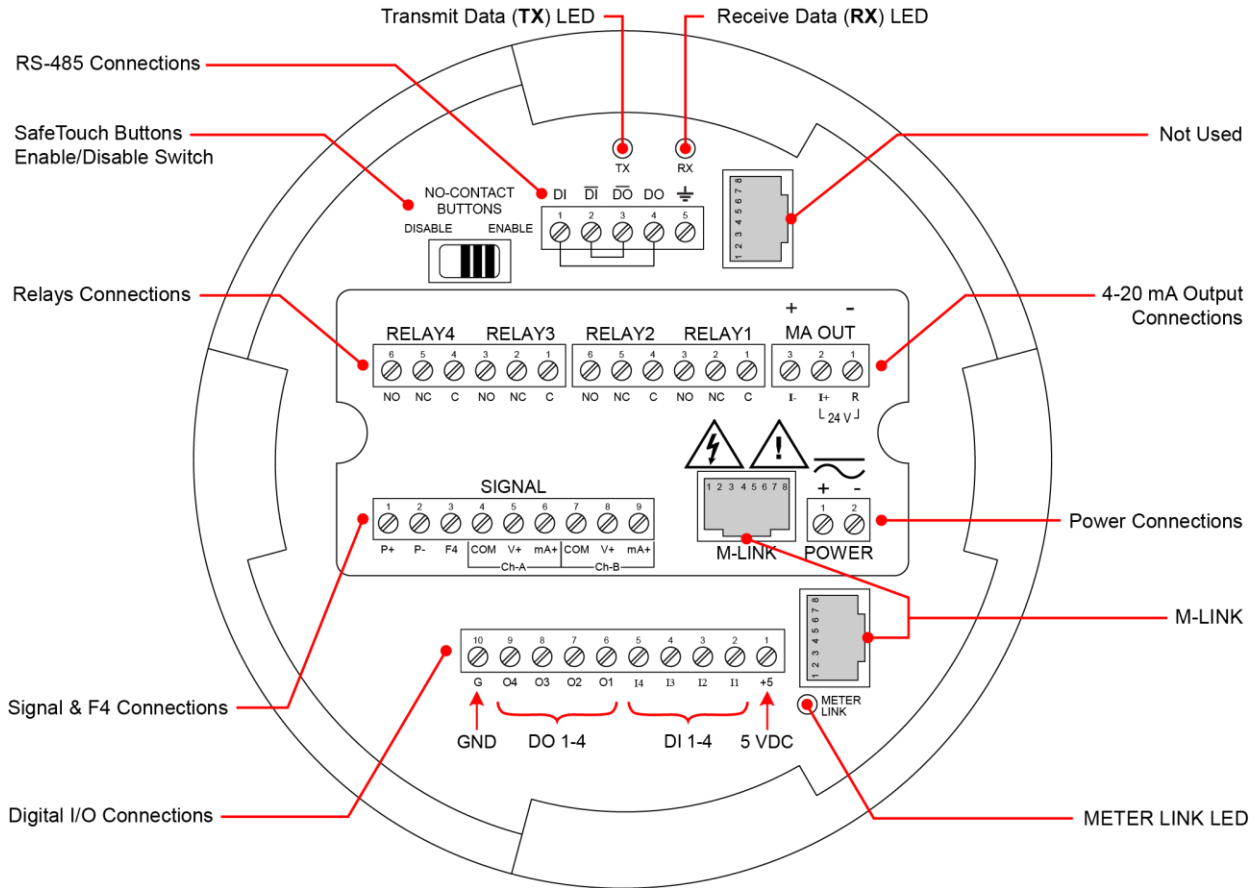

Figure 4. Integrated ProVu Required Connections

ProVu Electronics Module Layout for PD8-6060-6H7 and PD8-6060-7H7*



* For models PD8-6060-6H0 and PD8-6060-7H0, the upper set of connectors (RELAYs & MA OUT) are not present

Figure 5. ProVu Electronics Module Layout

USB Connection

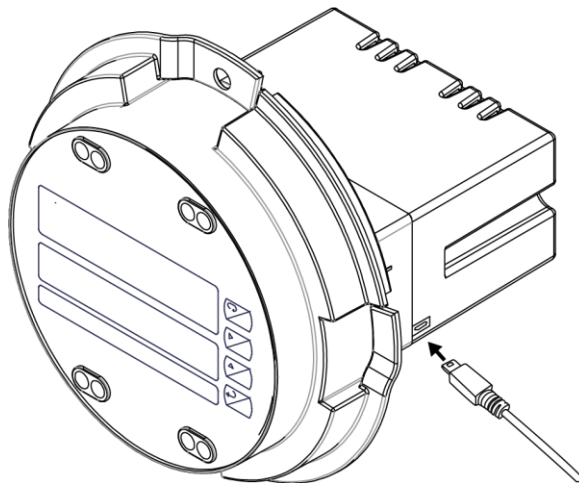

Figure 6. USB Connection

⚠ WARNINGS

- **DO NOT** disconnect the RJ45 M LINK connector cable. Otherwise the instrument will not function properly.
- The meter should only be connected to a computer while it is located in a safe area.

Power Connections

Power connections are made to a two-terminal connector labeled POWER. The meter will operate regardless of DC polarity connection. The + and - symbols are only a suggested wiring convention. There are separate models for low voltage and high voltage power. See *Ordering Information* on page 7 for details.

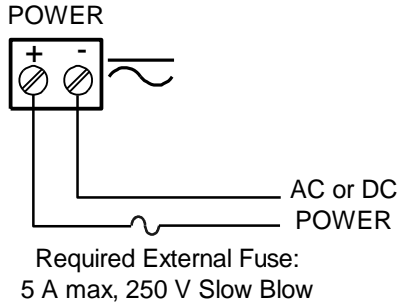

Figure 7. Power Connections

Signal Connections

Signal connections are made to a nine-terminal connector labeled SIGNAL. The COM (common) terminals are the return for the 4-20 mA and the ± 10 V input signals. The two COM terminals connect to the same common return and are not isolated.

Current (mA) Connections

The following figures show examples of current connections.

There are no switches or jumpers to set up for current and voltage inputs. Setup and programming is performed through the programming buttons or MeterView Pro software.

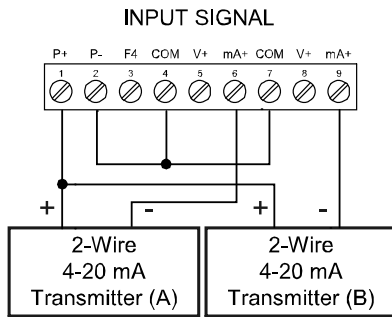

Figure 8. 2-Wire Transmitters Powered by Internal Supply

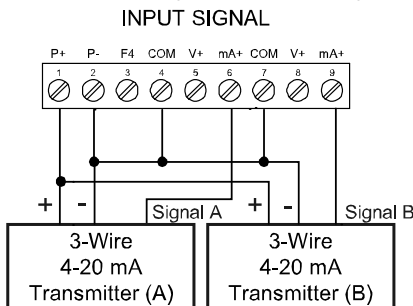

Figure 9. 3-Wire Transmitters Powered by Internal Supply

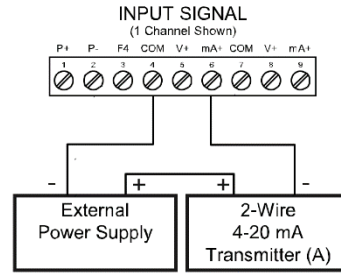

Figure 10. Transmitter Powered by External Supply

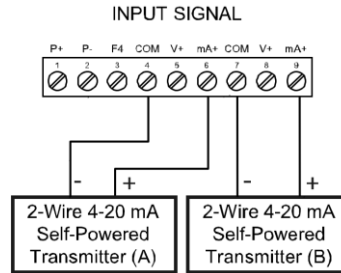

Figure 11. Self-Powered Transmitters

The current input is protected against current overload by an internal resettable fuse. The display may or may not show a fault condition depending on the nature of the overload.

The fuse limits the current to a safe level when it detects a fault condition, and automatically resets itself when the fault condition is removed.

Voltage (V) Connections

The following figures show examples of voltage connections.

There are no switches or jumpers to set up for voltage inputs. Setup and programming is performed through the programming buttons or MeterView Pro software.

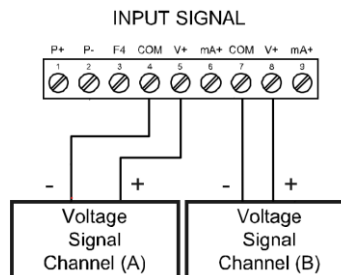

Figure 12. 2-Wire Voltage Input Connections

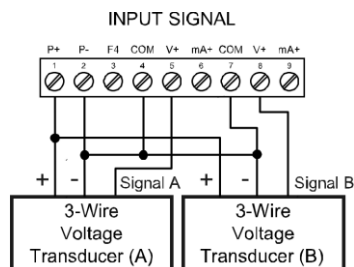

Figure 13. 3-Wire Voltage Input Connections

The meter is capable of accepting any voltage from -10 VDC to +10 VDC.

RS-485 Connections



The RS-485 connections are made to a five terminal connector used for Modbus® RTU serial communications. The RS-485 terminals include Transmit Data (DO) and (/DO), Receive Data (DI) and (/DI), and Signal Ground. See *Modbus® RTU Serial Communications (SERIAL)* on page 54 for more information.

There are three diagnostic LEDs: METER LINK, Transmit Data (TX), and Receive Data (RX) to show when the meter is transmitting and receiving data from other devices.

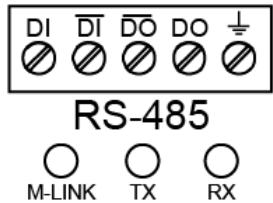

Figure 14. RS-485 Connection

RS-485 Multi-Drop Connection

When using more than one meter in a multi-drop mode, each meter must be provided with its own unique address. The meter address (Slave ID) can be programmed between 1 and 247. The transmit delay can be set between 0 and 199 ms. The parity can be set between 0 and 199 ms. The parity can be set to even, odd, or none with 1 or 2 stop bits.

To change the meter address:

1. Press and hold the Menu button for three seconds to access Advanced Features menu of the meter.
2. Press Up arrow until Serial (SERIAL) menu is displayed and press Enter, ADDR ES is displayed.
3. Press Enter to change meter address using Right and Up arrow buttons. Press Enter to accept.
4. Press Menu button to exit and return to Run Mode.

Three-Wire Connection

In order to wire the five pins for use as a three-wire half-duplex RS-485 connection, it is necessary to create a jumper connection between DI to DO and /DI to /DO- as shown below.

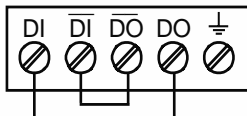
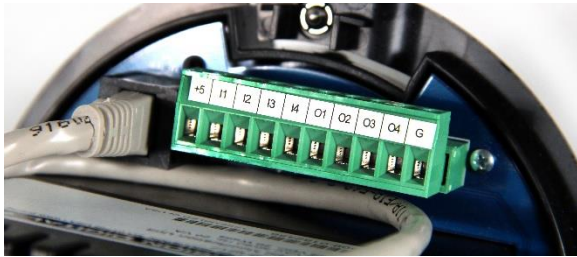

Figure 15. Three-Wire RS-485 Connection

Digital I/O Connections



The ProtEX-MAX has a 10-position terminal block for connecting digital inputs and outputs.

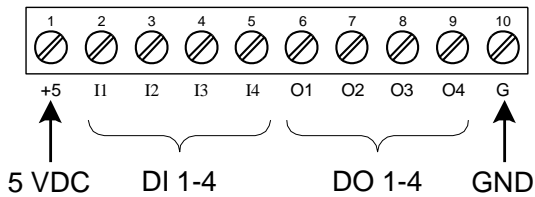

Figure 16. Digital Input and Output Connections

IMPORTANT

The onboard digital inputs (1-4) are configured at the factory to function identically to the front panel pushbuttons (Menu, F1, F2, & F3) in order to work with the SafeTouch buttons. Changing the programming of the digital inputs will affect the function of the SafeTouch buttons.

If you wish to change the behavior of the digital inputs, re-assign F1-F3 to the desired function, then change the corresponding digital input to match.

WARNING

- **DO NOT** disconnect the RJ45 M LINK connector cable. Otherwise the instrument will not function properly.

F4 Digital Input Connections

A digital input, F4, is standard on the meter. This digital input should be connected with a normally open contact across F4 and COM, or with an active low signal applied to F4. It can be used for remote operation of front-panel buttons, to acknowledge/reset relays, or to reset max/min values. See *Function Keys & Digital I/O Available Settings* on page 58 for a complete list of capabilities.

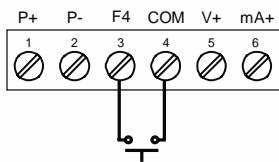

Figure 17. F4 Digital Input Connections

Remote Programming

The meter can be operated via the programming buttons or a remote control station with required approvals to be located in a hazardous area using the digital inputs and outputs.

4-20 mA Output Connections

Connections for the 4-20 mA transmitter output are made to the connector terminals labeled mA OUT. The 4-20 mA output may be powered internally or from an external power supply.

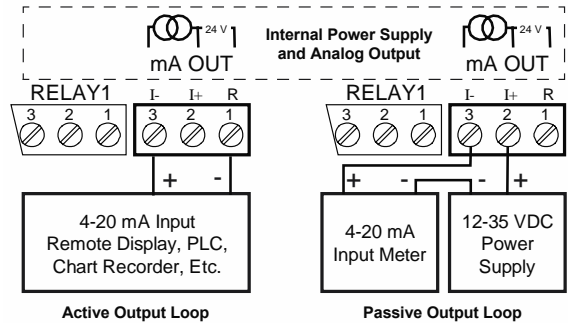

Figure 18. 4-20 mA Output Connections

Analog Output Power Supply

The internal 24 VDC power supply powering the analog output may be used to power other devices if the analog output is not used. The I+ terminal is the +24 V and the R terminal is the return.

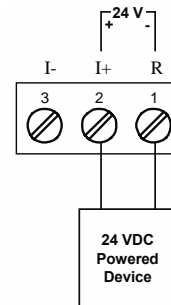

Figure 19. Analog Output Supply Powering Other Devices

Relay Connections

Relay connections are made to two six-terminal connectors labeled RELAY1 – RELAY4. Each relay's C terminal is common only to the normally open (NO) and normally closed (NC) contacts of the corresponding relay. The relays' C terminals should not be confused with the COM (common) terminal of the INPUT SIGNAL connector.

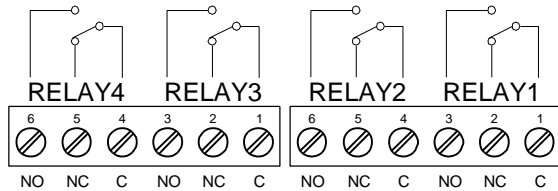

Figure 20. Relay Connections

Interlock Relay Feature

As the name implies, the interlock relay feature reassigns one, or more, alarm/control relays for use as interlock relay(s). Interlock contact(s) are wired to digital input(s) and activate the interlock relay. This feature is enabled by configuring the relay, and the corresponding digital input(s), see *Setting Up the Interlock Relay (Force On) Feature* on page 49.

In the example below, an Interlock Contact switch is connected to a digital input, which will be used to force on (energize) the Interlock Relay. The Interlock Relay and the Control Relay are connected in series with the load.

- When the Interlock Contact is closed (safe), the Interlock Relay energizes, allowing power to flow to the Control Relay; the corresponding front panel LED is on.
- When the Interlock Contact is open, the corresponding front panel LED flashes (locked out), the Interlock Relay is de-energized, preventing power from flowing to the Control Relay and the load.

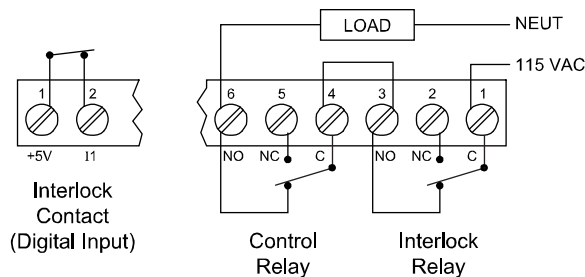

Figure 21. Interlock Connections

Switching Inductive Loads

The use of snubbers to suppress electrical noise is strongly recommended when switching inductive loads to prevent disrupting the microprocessor's operation. The snubbers also prolong the life of the relay contacts. Suppression can be obtained with resistor-capacitor (RC) networks assembled by the user or purchased as complete assemblies. Refer to the following circuits for RC network assembly and installation:

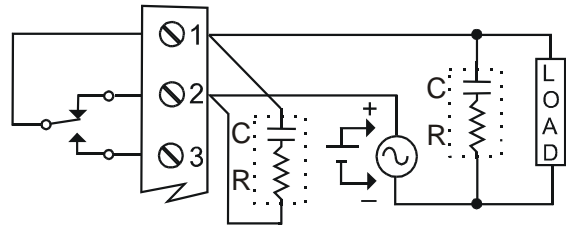

Figure 22. AC and DC Loads Protection

Choose R and C as follows:

- R: 0.5 to 1 Ω for each volt across the contacts
- C: 0.5 to 1 μF for each amp through closed contacts

Notes:

1. Use capacitors rated for 250 VAC.
2. RC networks may affect load release time of solenoid loads. Check to confirm proper operation.
3. Install the RC network at the meter's relay screw terminals. An RC network may also be installed across the load. Experiment for best results.

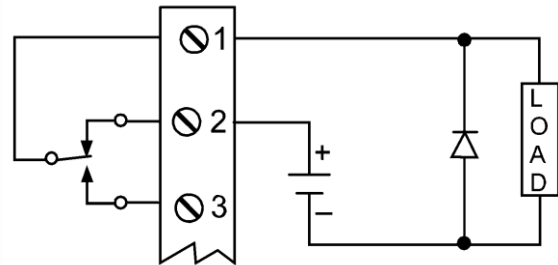

Use a diode with a reverse breakdown voltage two to three times the circuit voltage and forward current at least as large as the load current.

Figure 23. Low Voltage DC Loads Protection

RC Networks (Snubbers) Available from Precision Digital

RC networks are available from Precision Digital and should be applied to each relay contact switching an inductive load. Part number: [PDX6901](#).

Note: Relays are de-rated to 1/14th HP (50 watts) with an inductive load.

Setup and Programming

There is **no need to recalibrate** the meter when first received from the factory. The meter is **factory calibrated** prior to shipment for milliamps and volts with calibration equipment that is certified to NIST standards.

Overview





There are no jumpers to set for the meter input selection. Setup and programming is done using MeterView Pro or through the programming buttons. After power and input signal connections have been completed and verified, apply power to the meter.

LED Status Indicators



LED	State	Indication
1-4	Steady	Alarm condition based on set and reset points, independent of relay status in certain configurations. (Available on all meter configurations, including those without relays installed)
1-4	Flashing	Relay interlock switch open
1-4 & M	Flashing	Relay in manual control mode
T	Flashing	Meter in Tare mode
M	Flashing	Analog output in manual control mode
A	Steady	Channel A displayed
B	Steady	Channel B displayed
C	Steady	Channel C displayed

Programming Buttons

Button Symbol	Description
	Press to enter or exit Programming Mode, view settings, or exit max/min readings
	Press to reset max/min readings or other parameter/function assigned through the <i>User</i> menu
	Press to display max/min readings or other parameter/function assigned through the <i>User</i> menu
	Press to acknowledge relays or other parameters/function assigned through the <i>User</i> menu

- Press the Menu button to enter or exit the Programming Mode at any time.
- Press the Right arrow button to move to the next digit during digit or decimal point programming.
- Press or hold the Up arrow button to scroll through the menus, decimal point, or to increment the value of a digit.
- Press the Enter button to access a menu or to accept a setting.
- Press and hold the Menu button for three seconds to access the advanced features of the meter.

SafeTouch Buttons

The ProtEX-MAX is equipped with four sensors that operate as through-glass buttons so that it can be programmed and operated without removing the cover (and exposing the electronics) in a hazardous area.

These buttons can be disabled for security by selecting DISABLE on the switch labeled NO-CONTACT BUTTONS located on the connector board.

To actuate a button, press one finger to the glass directly over the marked button area. Then retract finger more than three inches from the glass before pressing the next button. When the cover is removed, the four mechanical buttons located next to the sensors are used. The sensors are disabled when a mechanical button is pressed and will automatically be re-enabled after 60 seconds of inactivity.

The SafeTouch Buttons are designed to filter normal levels of ambient interference and to protect against false triggering, however, it is recommended that the SafeTouch Buttons be disabled (slide switch to DISABLE) if there is an infrared interference source in line-of-sight to the display.

The SafeTouch Buttons are configured by default to duplicate the function of the front panel mechanical pushbuttons associated with the integrated meter. The symbols by each SafeTouch button correspond to a mechanical button as shown in the above table.

SafeTouch Button Tips:

- To the extent possible, install the display facing away from sunlight, windows, reflective objects and any sources of infrared interference.
- Keep the glass window clean.
- Tighten the cover securely.
- Use a password to prevent tampering.



Display Functions & Messages

The meter displays various functions and messages during setup, programming, and operation. The following table shows the main menu functions and messages in the order they appear in the menu.

Display Functions & Messages		
Display	Parameter	Action/Setting Description
ሪፎቲዎ	Setup	Enter Setup menu
ከፎቲዎ	Input	Enter Input selection menu
ከሐ-ጸ	Input	Set input type for channel A (*or B)
ጠገጸ	4-20 mA	Set meter for 4-20 mA input
ህዕሊቴ	0-10 VDC	Set meter for ±10 VDC input
ህጠቴ	Unit	Select the display units/tags
ከሐ-ጸ	Unit	Set unit or tag for channel A (*or B or C)
ደፎር ፆቴ	Decimal point	Set decimal point
ከሐ-ጸ	Decimal point	Set decimal point for channel A (*or B or C)
ፆሮፎ	Program	Enter the Program menu
ከፎርገገ	Input calibration	Enter the Input Calibration menu
ከሐ-ጸ	Input A	Set input type for channel A (*or B)
ሪፎርገገ ጸ	Scale A	Enter the Scale menu for channel A
ሪፎርገገ ሐ	Scale B	Enter the Scale menu for channel B
ፎርገገ ጸ	Calibrate A	Enter the Calibration menu for channel A
ፎርገገ ሐ	Calibrate B	Enter the Calibration menu for channel B
ከፎፆ 1	Input 1	Calibrate input 1 signal or program input 1 value
ደፆ 1	Display 1	Program display 1 value
ከፎፆ 2	Input 2	Calibrate input 2 signal or program input 2 value (up to 32 points)
ደፆ 2	Display 2	Program display 2 value (up to 32 points)
ፎሮሮ	Error	Error, calibration not successful, check signal or programmed value
ደሪፆሪገገ	Display	Enter the Display menu
ገገጠፎ 1	Line 1	Assign line 1 parameter
ገገጠፎ 2	Line 2	Assign line 2 parameter
ደ ከሐ-ጸ	Display Ch-A	Assign display to channel A
ደ ከሐ-ሐ	Display Ch-B	Assign display to channel B
ደ ከሐ-ፎ	Display Ch-C	Assign display to channel C (math)
ደ ጸሐ	Display AB	Alternate display of channel A & B
ደ ጸፎ	Display AC	Alternate display of channel A & C

Display Functions & Messages		
Display	Parameter	Action/Setting Description
ደ ሐፎ	Display BC	Alternate display of channel B & C
ደ ጸሐፎ	Display ABC	Alternate display of channel A, B, & C
ደ ሪፎፎ 1	Display set 1*	Displays relay 1(*through 4) set point.
ደ ጸገ-ጸ	Display high A	Display high value of channel A
ደ ገዕ-ጸ	Display low A	Display low value of channel A
ደ ጸገ-ጸ	Display hi/low A	Alternate between high/low value of channel A
ደ ጸገ-ሐ	Display high B	Display high value of channel B
ደ ገዕ-ሐ	Display low B	Display low value of channel B
ደ ጸገ-ሐ	Display high/low B	Alternate between high/low value of channel B
ደ ጸገ-ፎ	Display high C	Display high value of channel C
ደ ገዕ-ፎ	Display low C	Display low value of channel C
ደ ጸገ-ፎ	Display high/low C	Alternate between high/low value of channel C
ደ ጸ-ህ	Display A and units/tags	Alternate display of channel A and the unit/tag
ደ ሐ-ህ	Display B and units/tags	Alternate display of channel B and the unit/tag
ደ ፎ-ህ	Display C and units/tags	Alternate display of channel C and the unit/tag
ጸ ፎሮፆ	Display A gross	Display input channel A gross (no tare)
ጸ ጠቴ-ፎ	Display A net and gross	Alternate display of channel A net (tare) and gross (no tare)
ሐ ፎሮፆ	Display B gross	Display input channel B gross (no tare)
ሐ ጠቴ-ፎ	Display B net and gross	Alternate display of channel B net (tare) and gross (no tare)
ጠገ ሐህ	Display Modbus®	Display Modbus® input register
ደ ዕፎፎ	Display off	Display blank (line 2)
ደ ህጠቴ	Display unit	Display line 1 channel units
ደ ጠቴ	Display intensity	Set display intensity level from 1 to 8
ገፎሪገገ	Relay	Enter the Relay menu
ጸሪፎገገ	Assignment	Assign relays to channels or Modbus®
ጸሪፎገገ 1	Assign 1	Relay 1 assignment
ከሐ-ጸ	Channel A*	Assign relay to channel A (*or B or C)
ጠገ ሐህ	Modbus®	Assign relay to Modbus® register
ገፎፆ 1	Relay 1	Relay 1 setup

Display Functions & Messages		
Display	Parameter	Action/Setting Description
Rcት 1	Action 1	Set relay 1 action
ጸሀትፊ	Automatic	Set relay for automatic reset
ጸ-ጠገጸጠ	Auto-manual	Set relay for auto or manual reset any time
ጊጸትርጸ	Latching	Set relay for latching operation
ጊት-ርጊገ	Latching-cleared	Set relay for latching operation with manual reset only after alarm condition has cleared
ጸጊትፎገጠ	Alternate	Set relay for pump alternation control
ፍጸጠጋጊ	Sample	Set relay for sample time trigger control
ፀFF	Off	Turn relay off
ፍጸ ጊፊፍ	Fail-safe	Enter Fail-safe menu
ፍጊፍ 1	Fail-safe 1	Set relay 1 (*through 4) fail-safe operation
ፀጠ	On	Enable fail-safe operation
ፀFF	Off	Disable fail-safe operation
ፈፎገጸጸ	Delay	Enter relay Time Delay menu
ፈጊጸ 1	Delay 1	Enter relay 1 time delay setup
ፀጠ 1	On 1	Set relay 1 On time delay
ፀFF 1	Off 1	Set relay 1 Off time delay
ፈጊጸ 2	Delay 2	Enter relays 2-4 time delay setup
ፅገፎጸጸ	Loop break	Set relay condition if loop break detected
ፈጠጠገፎ	Ignore	Ignore loop break condition (Processed as a low signal condition)
ፀጠ	On	Relay goes to alarm condition when loop break detected
ፀFF	Off	Relay goes to non-alarm condition when loop break detected
ጸፀት	Analog output	Enter the Analog output scaling menu
ጸፀት 1	Aout channel	Analog Output source channel
ፈጊፍ 1	Display 1	Program display 1 value
ፀት 1	Output 1	Program output 1 value (e.g. 4.000 mA)
ፈጊፍ 2	Display 2	Program display 2 value
ፀት 2	Output 2	Program output 2 value (e.g. 20.000 mA)
ገፎፎፎት	Reset	Press Enter to access the Reset menu
ገፍት ጸ 1	Reset high	Press Enter to reset max display
ገፍት ጊፀ	Reset low	Press Enter to reset min display

Display Functions & Messages		
Display	Parameter	Action/Setting Description
ገፍት ጸጊ	Reset high & low	Press Enter to reset max & min displays
ገፍት ፎገ	Reset tare	Press Enter to reset (cancel) tare
ፎጠፎገጊ	Control	Enter Control menu
ጸሀትፊ	Automatic	Press Enter to set meter for automatic operation
ጠገጸጠ	Manual	Press Enter to manually control relays or analog output operation
ፆጸፍፍ	Password	Enter the Password menu
ፆጸፍፍ 1	Password 1*	Set or enter Password 1 (*through 3)
ጠጊጠ	Unlocked	Program password to lock meter
ጊጠፈ	Locked	Enter password to unlock meter
999999 -999999	Flashing	Over/under range condition

Main Menu

The main menu consists of the most commonly used functions: *Setup*, *Reset*, *Control*, and *Password*.

- Press Menu button to enter Programming Mode then press the Up arrow button to scroll main menu.
- Press Menu, at any time, to exit and return to Run Mode. Changes made to settings prior to pressing Enter are not saved.
- Changes to the settings are saved to memory only after pressing Enter/F3.
- The display moves to the next menu every time a setting is accepted by pressing Enter/F3.

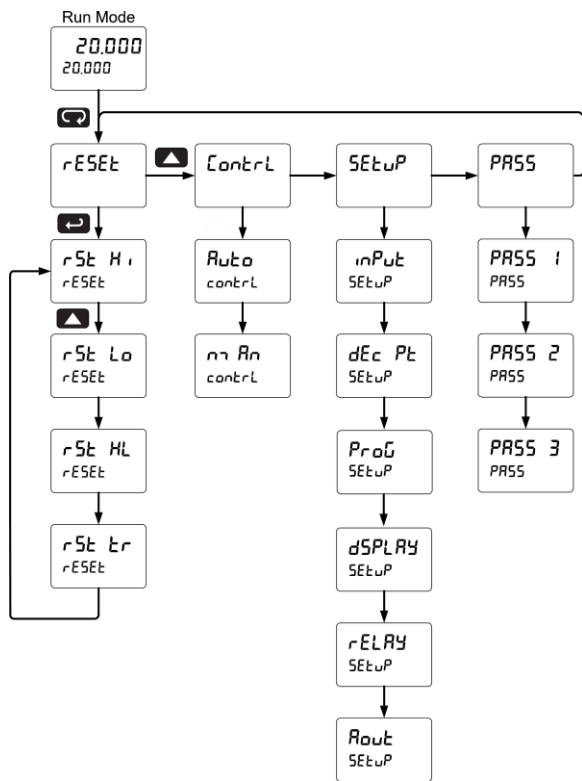

Setting Numeric Values

The numeric values are set using the Right and Up arrow buttons. Press Right arrow to select next digit and Up arrow to increment digit value. The digit being changed is displayed brighter than the rest.

Press and hold Up to auto-increment the display value. If negative numbers are allowed, the first digit position will include a negative symbol (-) after the 9. Press the Enter button, at any time, to accept a setting or Menu button to exit without saving changes.

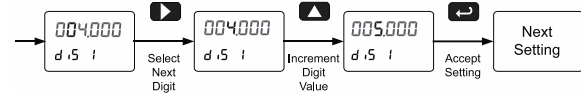

Setting Up the Meter (SEtUP)

The *Setup* menu is used to select:

1. Input signal the meter will accept for channel A and channel B
2. Units for A, B, and C
3. Decimal point position for A, B, and C
4. Program the meter using the Scale or Calibrate functions
5. Display parameter and intensity
6. Relay assignment and operation
7. 4-20 mA analog output scaling

Press the Enter button to access any menu or press Up arrow button to scroll through choices. Press the Menu button to exit at any time.

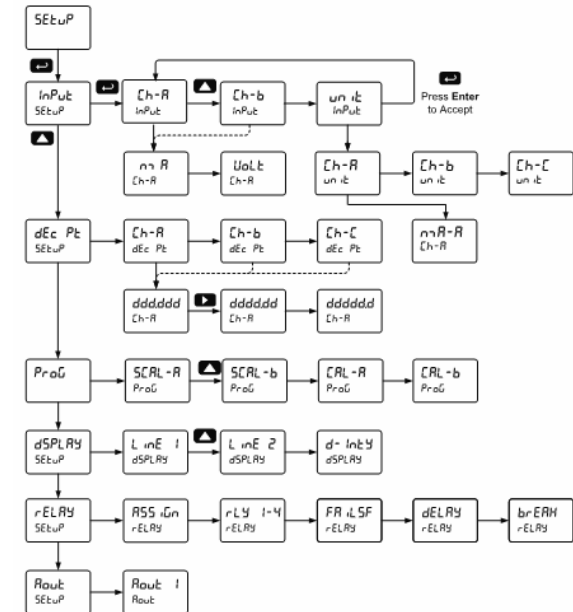

Setting the Input Signal (Input)

Enter the *Input* menu to set up the meter to display current (mA) or voltage (VDC) inputs for channel A and channel B.

The current input is capable of accepting any signal from 0 to 20 mA. Select current input to accept 0-20 mA or 4-20 mA signals.

The voltage input is capable of accepting any signal from -10 to +10 VDC. Select voltage input to accept 0-5, 1-5, 0-10, or ±10 VDC signals.

Channel C is the Math Function calculation, which is set up in the Advanced Features menu.

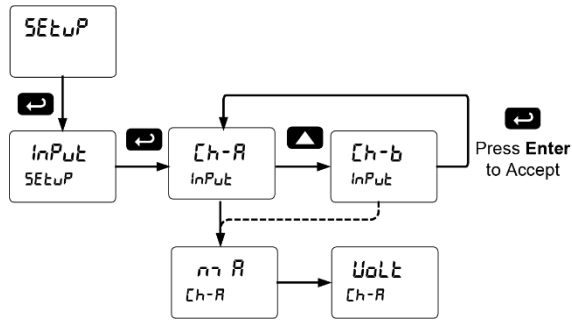

Setting the Display Units or Custom Tags (Unit)

Enter the display unit or custom tag that will be displayed if *Unit* is selected as the line 2 parameter. See the *Setting the Display Parameter & Intensity (Display)* flow chart on page 41 to access the display menu to show the unit or tag on display line 2. The engineering units or custom legends can be set using the following 7-segment character set:

Display	Character
0	0
1	1
2	2
3	3
4	4
5	5
6	6
7	7
8	8
9	9
A	A
b	b
C	C
c	c
d	d
E	E
F	F
G	G
g	g
H	H
h	h
I	I
i	i
J	J

Display	Character
K	K
L	L
m	m
n	n
O	O
o	o
P	P
q	q
r	r
S	S
t	t
u	u
V	V
w	w
X	X
Y	Y
Z	Z
.	.
/	/
]]
[[
=	=
Degree(<)	Degree(<)
Space	Space

Notes:

1. Degree symbol represented by (<) if programming with MeterView Pro.
2. The letters "m" and "w" use two 7-segment LEDs each; when selected the characters to the right are shifted one position.
3. Press and hold up arrow to auto-scroll the characters in the display.

Setting the Decimal Point (dEc Pt)

The decimal point may be set with up to five decimal places or with no decimal point at all. Pressing the Right arrow moves the decimal point one place to the right until no decimal point is displayed, and then it moves to the leftmost position. There are three decimal points to set up for three channels: Ch-A, Ch-B, and Ch-C. After the decimal points are set up, the meter moves to the *Program* menu.

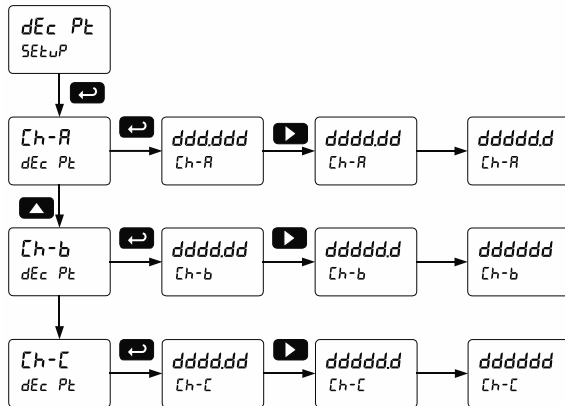

Programming the Meter (PrOG)

The meter may either be scaled (SCAL) without applying an input or calibrated (CAL) by applying an input. The meter comes factory calibrated to NIST standards, so for initial setup, it is recommended to use the (SCAL) function.

The Program menu contains the Scale (SCALE) and the Calibrate (CAL) menus.

Process inputs may be scaled or calibrated to any display within the range of the meter.

Note: The **Scale** and **Calibrate** functions are exclusive of each other. The meter uses the last function programmed. Only one of these methods can be employed at a time. The Scale and Calibrate functions can use up to 32 points (default is 2). The number of points should be set in the Advanced Menu prior to scaling and calibration of the meter. See Multi-Point Linearization (LnERr) on page 55 for details.

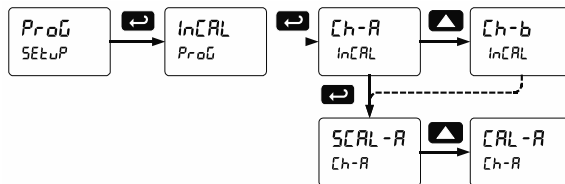

Multi-Point Linearization (LnERr)

The process inputs may be calibrated or scaled to any display value within the range of the meter. The meter is set up at the factory for 2-point linear calibration.

Up to 32 linearization points may be selected. See *Multi-Point Linearization (LnERr)* on page 55 for details.

Scaling the Meter (SCALE)

The process inputs (4-20 mA, ±10 VDC) can be scaled to display the process variables in engineering units.

A signal source is not needed to scale the meter; simply program the inputs and corresponding display values.

Scaling the Meter for Channel A (SCAL-A)

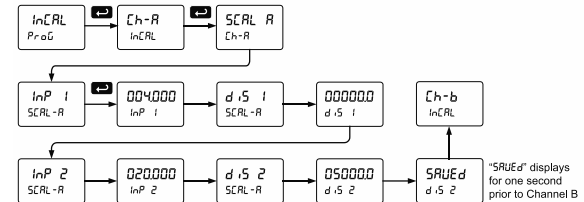

Scaling the Meter for Channel B (SCAL-b)

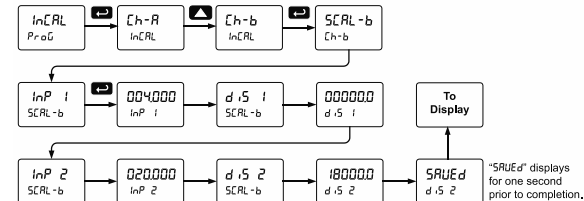

For instructions on how to program numeric values see *Setting Numeric Values*, page 37.

Error Message (Error)

An error message indicates that the calibration or scaling process was not successful.

After the error message is displayed, the meter reverts to input 2 during calibration or scaling and to input 1 during internal calibration, allowing the appropriate input signal to be applied or programmed.

The error message might be caused by any of the following conditions:

1. Input signal is not connected to the proper terminals or it is connected backwards.
2. Wrong signal selection in *Setup* menu.
3. Minimum input span requirements not maintained.
4. Input 1 signal inadvertently applied to calibrate input 2.

Minimum Input Span

The minimum input span is the minimum difference between input 1 and input 2 signals required to complete the calibration or scaling of the meter.

Input Range	Input 1 & Input 2 Span
4-20 mA	0.15 mA
±10 VDC	0.10 VDC

Calibrating the Meter with External Source (E_{RL})

Note: To scale the meter without a signal source, refer to Scaling the Meter (S_{RL}E) on page 39.

The meter can be calibrated to display the process variable in engineering units by applying the appropriate input signal and following the calibration procedure.

The use of a calibrated signal source is strongly recommended to calibrate the meter.

Warm up the meter for at least 15 minutes before performing calibration to ensure specified accuracy.

Calibrating the Meter for Channel A (E_{RL}-R)

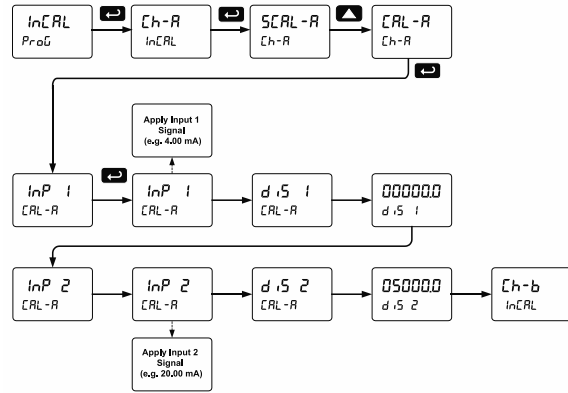

Note: Inputs for the above example are:
 Input 1: 4.00 mA; Display 1: 0.0 Gallons
 Input 2: 20.00 mA; Display 2: 5000.0 Gallons

Calibrating the Meter for Channel B (E_{RL}-b)

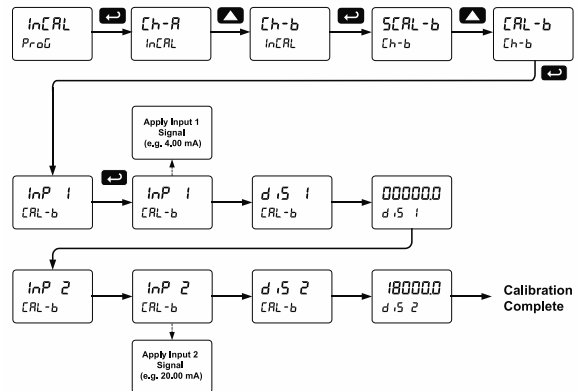

Note: Inputs for the above example are:
 Input 1: 4.00 mA; Display 1: 0.0 Gallons
 Input 2: 20.00 mA; Display 2: 18000.0 Gallons

Setting the Display Parameter & Intensity (dSPLY)

The main display (LINE 1) can be programmed to display:

1. Process value Ch-A
2. Process value Ch-B
3. Process value Ch-C
4. Toggle between Ch-A & Ch-B, Ch-A & Ch-C, Ch-B & Ch-C, and Ch-A, Ch-B, & Ch-C
5. Relay set points
6. Max & min values for each channel
7. Toggle between Channel & units
8. Channel gross value (no tare) or toggle net (tare) and gross values
9. Modbus® input

The secondary display (LINE 2) can be programmed to display:

1. Process value Ch-A
2. Process value Ch-B
3. Process value Ch-C
4. Toggle between Ch-A & Ch-B, Ch-A & Ch-C, Ch-B & Ch-C, and Ch-A, Ch-B, & Ch-C
5. Relay set points
6. Max & min values for each channel
7. Toggle between Channel & units
8. Channel gross value (no tare) or toggle net (tare) and gross values
9. Modbus® input
10. Off (no display)
11. Engineering units or custom legends

After setting up the input and display, press the Menu button to exit programming and skip the rest of the setup menu.

The displays can be set up to read channels A, B, or C, toggle between A & B, B & C, A & C, A & B & C, toggle between channels A, B, or C & units, the max/min of any of the channels, including the math channel (C), set points, gross (without tare) or net (with tare) & gross values of channel A or B, or the Modbus® input. In addition to the parameters available on the main display, the second display can display Engineering units or it could be turned off.

Display Intensity (d-INTY)

The meter has eight display intensity levels to give the best performance under various lighting conditions. Select intensity 8 for outdoor applications. The default intensity is 6.

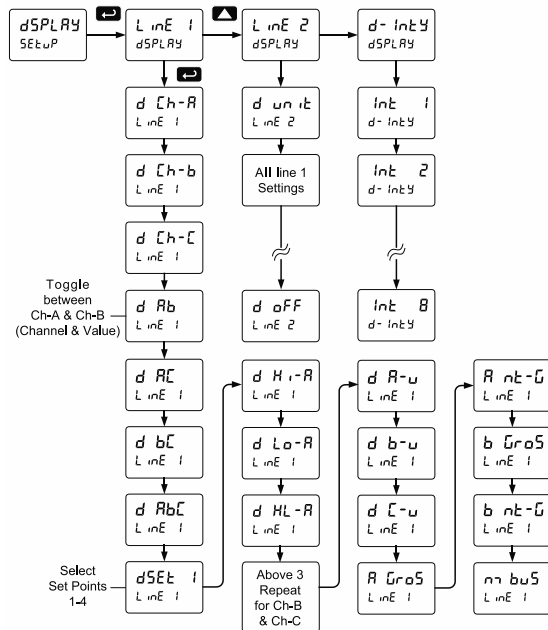

Setting the Relay Operation (rELAY)

This menu is used to set up the assignment and operation of the relays.

CAUTION

- During setup, the relays do not follow the input and they will remain in the state found prior to entering the Relay menu.

1. Relay assignment
 - a. Channel A
 - b. Channel B
 - c. Channel C (Math channel)
 - d. Modbus®
2. Relay action
 - a. Automatic reset only (non-latching)
 - b. Automatic + manual reset at any time (non-latching)
 - c. Latching (manual reset only)
 - d. Latching with Clear (manual reset only after alarm condition has cleared)
 - e. Pump alternation control (automatic reset only)
 - f. Sampling (the relay is activated for a user-specified time)
 - g. Off (relay state controlled by Interlock feature)
3. Set point
4. Reset point
5. Fail-safe operation
 - a. On (enabled)
 - b. Off (disabled)
6. Time delay
 - a. On delay (0-999.9 seconds)
 - b. Off delay (0-999.9 seconds)
7. Relay action for loss (break) of 4-20 mA input (ignore, on, off)

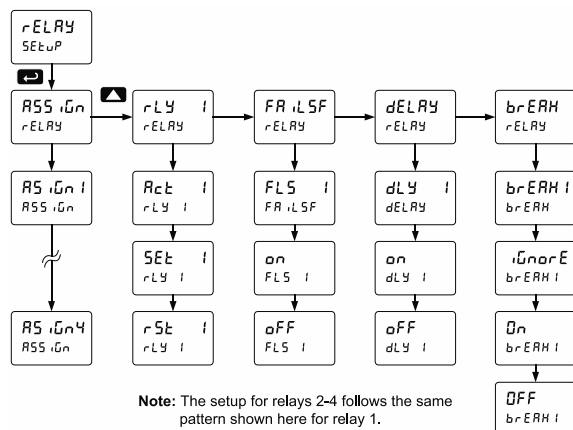

Note: The setup for relays 2-4 follows the same pattern shown here for relay 1.

Setting the Relay Assignment (ASSIGN)

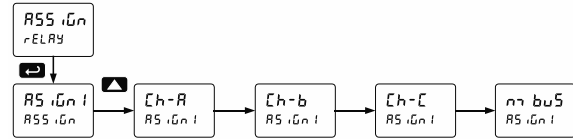

Setting the Relay Action

Operation of the relays is programmed in the Action menu. The relays may be set up for any of the following modes of operation:

1. Automatic reset (non-latching)
2. Automatic + manual reset at any time (non-latching)
3. Latching (manual reset only, at any time)
4. Latching with Clear (manual reset only after alarm condition has cleared)
5. Pump alternation control (automatic reset only)
6. Sampling (the relay is activated for a user-specified time)
7. Off (relay state controlled by Interlock feature)

The following graphic shows relay 1 action setup; relay 2-4 are set up in a similar fashion.



Programming Set and Reset Points

High alarm indication: program set point above reset point.

Low alarm indication: program set point below reset point.

The deadband is determined by the difference between set and reset points. Minimum deadband is one display count. If the set and reset points are programmed with the same value, the relay will reset one count below the set point.

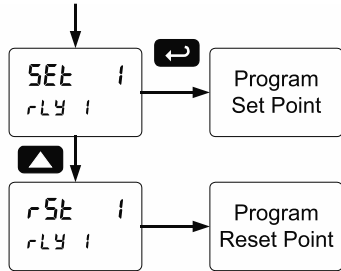

Note: Changes are not saved until the reset point has been accepted.

Setting Fail-Safe Operation

In fail-safe mode of operation, the relay coil is energized when the process variable is within safe limits and the relay coil is de-energized when the alarm condition exists. The fail-safe operation is set independently for each relay. Select **on** to enable or select **off** to disable fail-safe operation.

Programming Time Delay

The *On* and *Off* time delays may be programmed for each relay between 0 and 999.9 seconds. The relays will transfer only after the condition has been maintained for the corresponding time delay.

The *On* time delay is associated with the set point.

The *Off* time delay is associated with the reset point.

Relay Action for Loss of 4-20 mA Input (Loop Break)

The loop break feature is associated with the 4-20 mA input. Each relay may be programmed to go to one of the following conditions when the meter detects the loss of the input signal (i.e. < 0.005 mA):

1. Turn *On* (Go to alarm condition)
2. Turn *Off* (Go to non-alarm condition)
3. Ignore (Processed as a low signal condition)

Note: This is not a true loop break condition; if the signal drops below 0.005 mA, it is interpreted as a "loop break" condition.

The following graph shows the loop break relay operation for a high alarm relay.

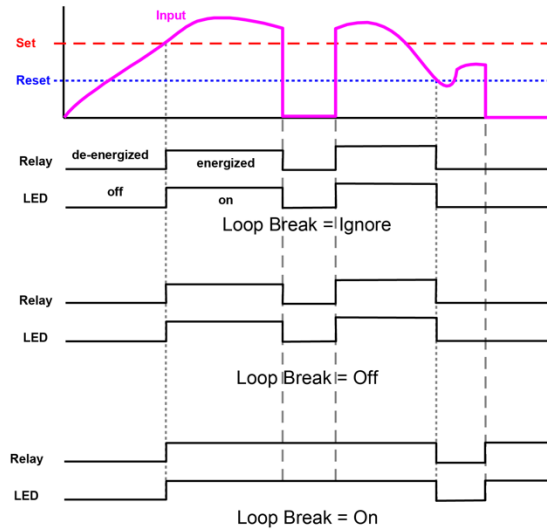

Relay and Alarm Operation Diagrams

The following graphs illustrate the operation of the relays, status LEDs, and ACK button.

High Alarm Operation (Set > Reset)

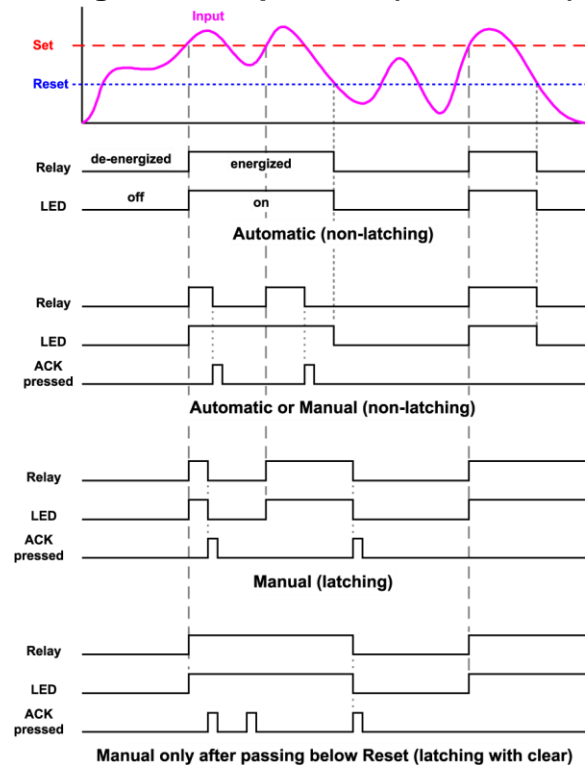

For Manual reset mode, ACK can be pressed anytime to turn "off" relay. To detect a new alarm condition, the signal must go below the set point, and then go above it.

Low Alarm Operation (Set < Reset)

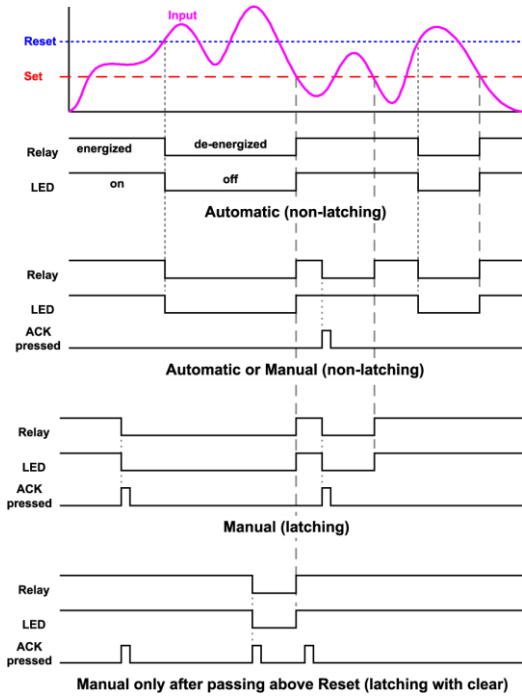

For Manual reset mode, ACK can be pressed anytime to turn "off" relay. For relay to turn back "on", signal must go above set point and then go below it.

Low Alarm with Fail-Safe Operation (Set < Reset)

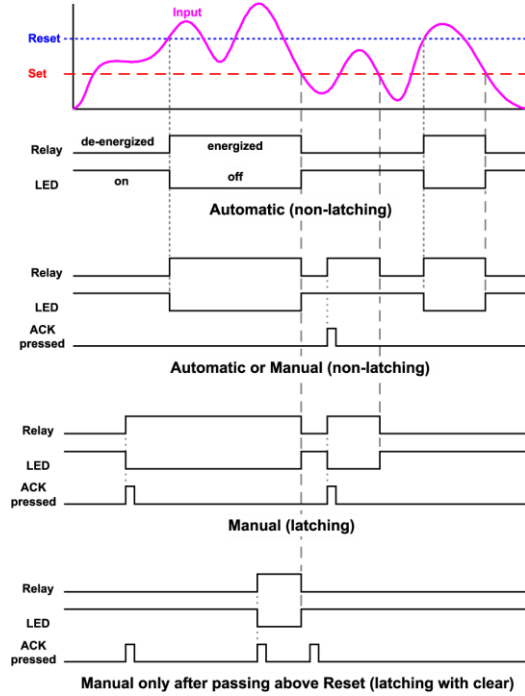

Note: Relay coil is energized in non-alarm condition. In case of power failure, relay will go to alarm state.

High Alarm with Fail-Safe Operation (Set > Reset)

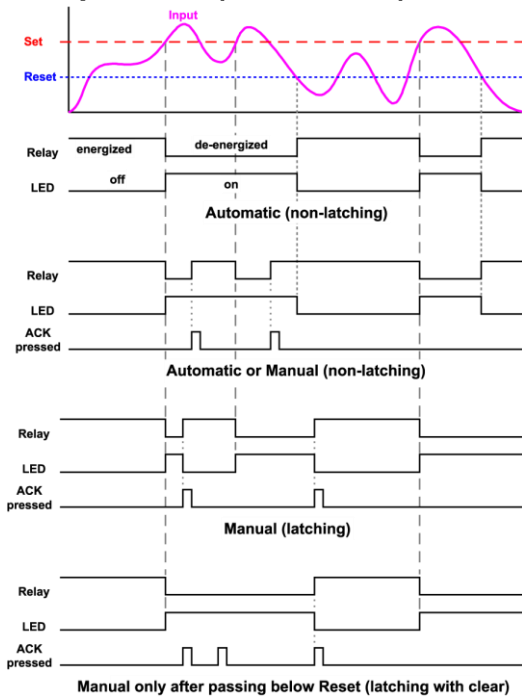

Note: Relay coil is energized in non-alarm condition. In case of power failure, relay will go to alarm state.

Time Delay Operation

The following graphs show the operation of the time delay function.

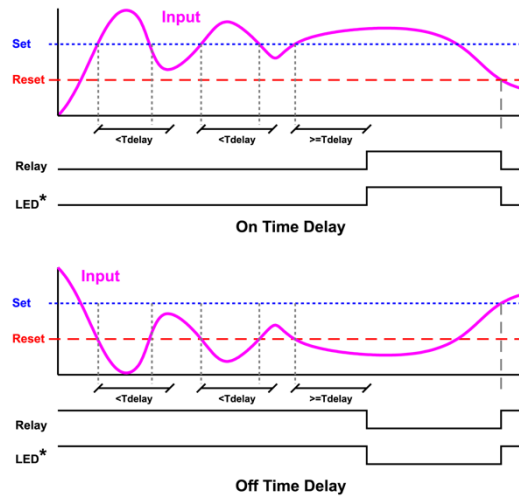

When the signal crosses the set point, the *On* time delay timer starts and the relay trips when the time delay has elapsed. If the signal drops below the set point (high alarm) before the time delay has elapsed, the *On* time delay timer resets and the relay does not change state. The same principle applies to the *Off* time delay.

Note: If "Automatic or Manual (R-n-Rn)" reset mode is selected, the LED follows the reset point and not the relay state when the relay is acknowledged.

Pump Alternation Control Operation

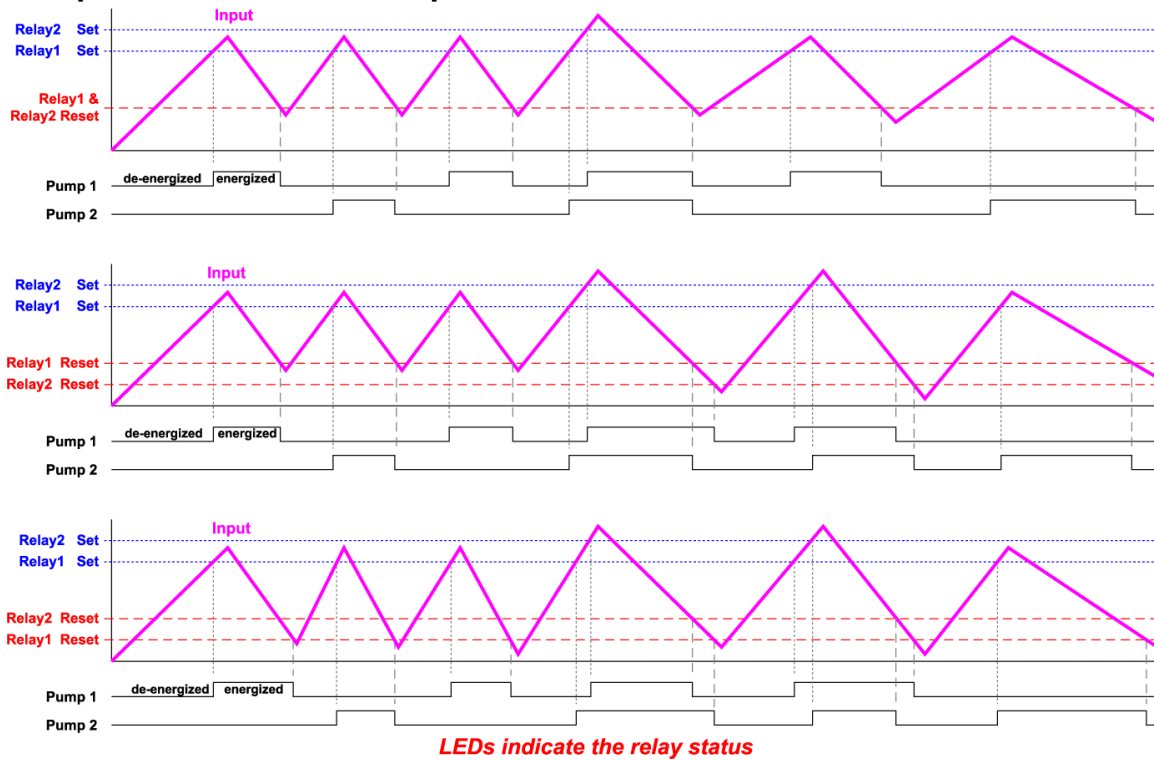

Relay Sampling Operation

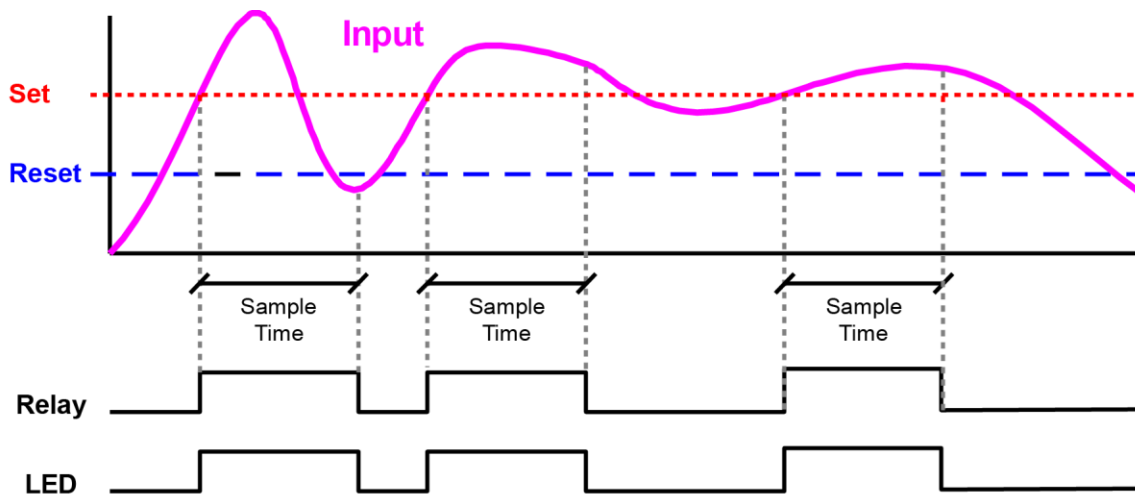

When the signal crosses the set point, the relay trips and the sample time starts. After the sample time has elapsed, the relay resets. The cycle repeats every time the set point is crossed, going up for high alarms and going down for low alarms.

The sample time can be programmed between 0.1 and 5999.9 seconds.

Relay Operation Details

Overview

The four-relays option for the meter expands its usefulness beyond simple indication to provide users with alarm and control functions. Typical applications include high and low temperature, level, pressure or flow alarms, control applications such as simple on/off pump control, and pump alternation control for up to 4 pumps. There are four basic ways the relays can be used:

1. High and Low Alarms with Latching or Non-Latching Relays
2. Simple On/Off Control with 100% Adjustable Deadband
3. Sampling (Based on Time)
4. Pump Alternation Control for up to 4 Pumps

Relays Auto Initialization

When power is applied to the meter, the front panel LEDs and alarm relays will reflect the state of the input to the meter. The following table indicates how the alarm LEDs and relays will react on power-up based on the set and reset points:

Alarm #	HI or LO Alarm	Set Point	Reset Point	Power-Up Reading	Relay & LED
1	HI	1000	500	499	Off
2	LO	700	900	499	On
3	LO	250	400	499	Off
4	HI	450	200	499	On

Fail-Safe Operation

The following table indicates how the relays behave based on the fail-safe selection for each relay:

Fail-Safe Selection	Non-Alarm State		Alarm State		Power Failure
	NO	NC	NO	NC	
Off	Open	Closed	Closed	Open	Relays go to non-alarm state
On	Closed	Open	Open	Closed	Relays go to alarm state

Note: NO = Normally Open, NC = Normally Closed. This refers to the condition of the relay contacts when the power to the meter is off.

Front Panel LEDs

The alarm status LEDs on the front panel are available on all meters, even those without relays installed, and provide status indication for the following:

LED	Status
1	Alarm 1
2	Alarm 2
3	Alarm 3
4	Alarm 4

The meter is supplied with four alarm points that include front panel LEDs to indicate alarm conditions. This standard feature is particularly useful for alarm applications that require visual-only indication. The LEDs are controlled by the set and reset points programmed by the user. When the display reaches a set point for a high or low alarm, the corresponding alarm LED will turn on. When the display returns to the reset point the LED will go off. The front panel LEDs respond differently for latching and non-latching relays.

For non-latching relays, the LED is always off during normal condition and always on during alarm condition, regardless of the state of the relay (e.g. Relay acknowledged after alarm condition).

For latching relays, the alarm LEDs reflect the status of the relays, regardless of the alarm condition. The following tables illustrate how the alarm LEDs function in relation to the relays and the acknowledge button (Default: F3 key assigned to ACK).

Latching and Non-Latching Relay Operation

The relays can be set up for latching (manual reset) or non-latching (automatic reset) operation.

Relay terminology for following tables	
Terminology	Relay Condition
On	Alarm (Tripped)
Off	Normal (Reset)
Ack	Acknowledged

The On and Off terminology does not refer to the status of the relay's coil, which depends on the fail-safe mode selected.

WARNING

- In latching relay mode, if Fail-Safe is off, latched relays will reset (unlatch) when power is cycled.

Non-Latching Relay (ꠁꠁꠂꠃ)

In this application, the meter is set up for automatic reset (non-latching relay). Acknowledging the alarm while it is still present has no effect on either the LED or the relay. When the alarm finally goes away, the relay automatically resets and the LED also goes off.

Automatic reset only		
Condition	LED	Relay
Normal	Off	Off
Alarm	On	On
Ack (No effect)	On	On
Normal	Off	Off

Non-Latching Relay with Manual Reset (ꠁꠁꠂꠃꠄꠅ꠆ꠇ)

In this application, the meter is set up for automatic and manual reset at any time (non-latching relay). The LED and the relay automatically reset when the meter returns to the normal condition.

In addition, the relay can be manually reset while the alarm condition still exists, but the LED will stay on until the meter returns to the normal condition.

Automatic + manual reset at any time		
Condition	LED	Relay
Normal	Off	Off
Alarm	On	On
Normal	Off	Off
Next Alarm	On	On
Ack	On	Off
Normal	Off	Off

Latching Relay (ꠁꠁꠂꠃꠄ)

In this application, the meter is set up for manual reset at any time. Acknowledging the alarm even if the alarm condition is still present resets the relay and turns off the LED.

Manual reset any time		
Condition	LED	Relay
Normal	Off	Off
Alarm	On	On
Ack	Off	Off

Latching Relay with Clear (ꠁꠁꠂꠃꠄꠅ꠆ꠇꠈꠉ)

In this application, the meter is set up for manual reset only after the signal passes the reset point (alarm condition has cleared). Acknowledging the alarm while it is still present has no effect on either the LED or the relay. When the alarm is acknowledged after it returns to the normal state, the LED and the relay go off. Notice that the LED remains on, even after the meter returns to the normal condition. This is because, for latching relays, the alarm LED reflects the status of the relay, regardless of the alarm condition.

Manual reset only after alarm condition has cleared		
Condition	LED	Relay
Normal	Off	Off
Alarm	On	On
Ack (No effect)	On	On
Normal	On	On
Ack	Off	Off

Acknowledging Relays

There are three ways to acknowledge relays programmed for manual reset:

1. Via the programmable front panel function keys F1-F3 (Example: F3 assigned to ACK).



2. Remotely via a normally open push button wired to the F4 terminal.

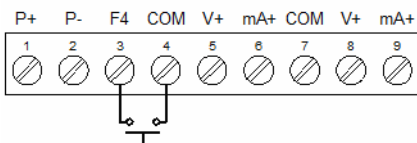

3. Remotely via a normally open push button wired to one of the digital inputs and the +5 V terminal on the digital I/O connections.

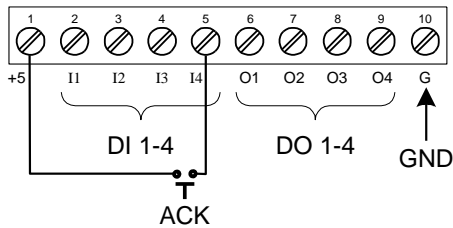

When the ACK button or the assigned digital input is closed, all relays programmed for manual reset are acknowledged.

Pump Alternation Control Applications (RL&ER)

For pump control applications where two or more similar pumps are used to control the level of a tank or a well, it is desirable to have all the pumps operate alternately. This prevents excessive wear and overheating of one pump over the lack of use of the other pumps.

Up to 4 relays can be set up to alternate every time an on/off pump cycle is completed. The set points and reset points can be programmed, so that the first pump on is the first pump off.

Application #1: Pump Alternation Using Relays 1 & 2

1. Relays 1 and 2 are set up for pump alternation.
2. Relays 3 and 4 are set up for low and high alarm indication.

Set and Reset Point Programming			
Relay	Set Point	Reset Point	Function
1	30.000	10.000	Controls pump #1
2	35.000	5.000	Controls pump #2
3	4.000	9.000	Controls low alarm
4	40.000	29.000	Controls high alarm

Pump Alternation Operation

1. Pump #1 turns on when level reaches 30.000, when level drops below 10.000, pump #1 turns off.
2. The next time level reaches 30.000, pump #2 turns on, when level drops below 10.000, pump #2 turns off.
3. If the level doesn't reach 35.000, pump #1 and pump #2 will be operating alternately.
4. If pump #1 cannot keep the level below 35.000, pump #2 will turn on at 35.000, then as the level drops to 10.000, pump #1 turns off, pump #2 is still running and shuts off below 5.000.
5. Notice that with the set and reset points of pump #2 outside the range of pump #1, the first pump on is the first pump to go off. This is true for up to 4 alternating pumps, if setup accordingly.
6. Relay #3 will go into alarm if the level drops below 4.000 and relay #4 will go into alarm if the level exceeds 40.000.

Pump Alternation Visual Representation

The following graphics provide a visual representation of a typical pump alternation application with high and low alarm monitoring using one of the PD8-6060's inputs:

1. Relay #4 turns the main pump on at 6000 gallons and turns it off at 1000 gallons.

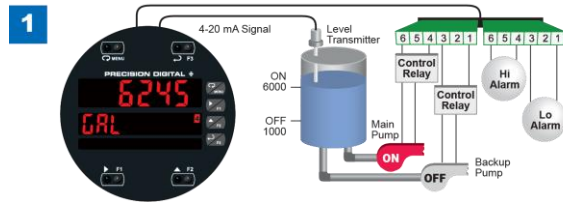

2. With the Pump Alternation feature activated, the next time the level reaches 6000 gallons, relay #3 transfers and starts the backup pump.

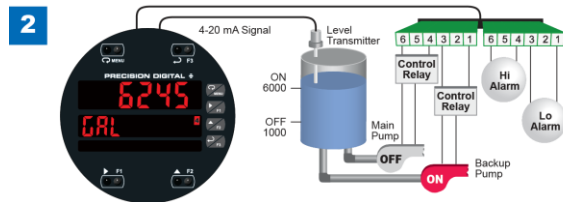

3. If the backup pump is not able to keep up, and the level reaches 7000 gallons, relay #4 transfers and starts the main pump as well.

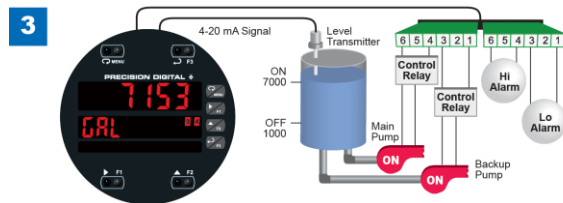

4. Relay #2 trips the High Level Alarm at 7500 gallons and resets at 6900 gallons.

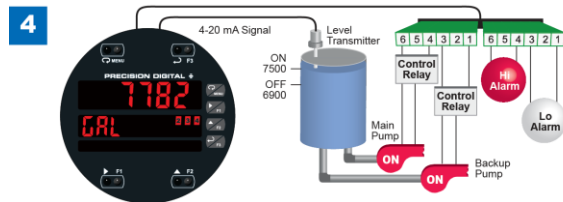

5. Relay #1 trips the Low Level Alarm at 495 gallons and resets at 750 gallons.

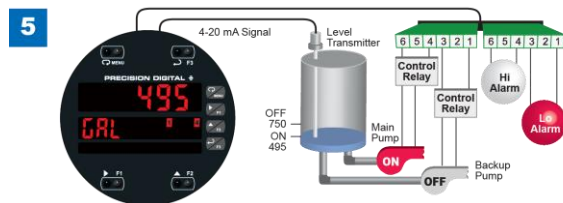

Setting Up the Interlock Relay (Force On) Feature

Relays 1-4 can be set up as interlock relays. To set up the relays for the interlock feature:

1. Access the *Setup – Relay – Action* menu and set the action to off.

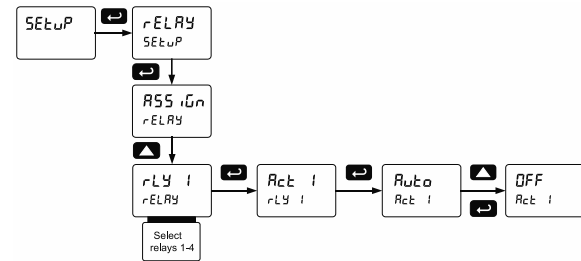

2. In the *Advanced features – User* menu program any of the digital inputs to *Force On* any of the internal relays (1-4).

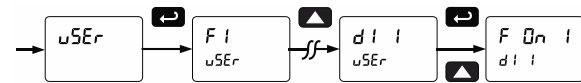

3. Connect a switch or dry contact between the +5V terminal and the corresponding digital input (dl-1 to dl-4) terminal.

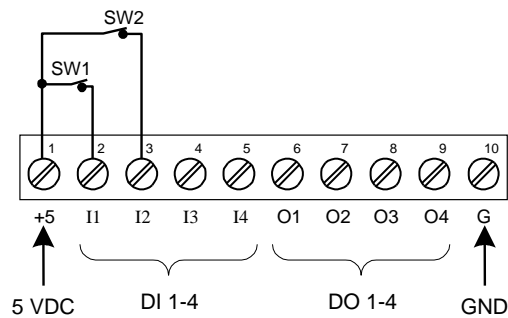

Interlock Relay Operation Example

Relays 1 & 2 are configured to energize (their front panel LEDs are steady on) when SW1 & SW2 switches (above) are closed. If the contacts to these digital inputs are opened, the corresponding front panel LEDs flash indicating this condition. The processes being controlled by the interlock relay will stop, and will re-start only after the interlock relay is re-activated by the digital inputs (switches).

Note: If multiple digital inputs are assigned to the same relay, then the corresponding logic is (AND) – i.e. both switches must be closed to activate the relay.

IMPORTANT

- If the digital inputs are assigned to the *Interlock Function*, then they cannot be used to program the meter remotely.

Scaling the 4-20 mA Analog Output (Rout)

The 4-20 mA analog output can be scaled to provide a 4-20 mA signal for any display range selected. To select the channel and source assignments the analog output is assigned to, see *Analog Output Source* on page 57.

No equipment is needed to scale the analog output; simply program the display values to the corresponding mA output signal.

The *Analog Output* menu is used to program the 4-20 mA outputs based on display values.

For further details, see *Setting Numeric Values* on page 37, *Analog Output Value for Loss of 4-20 mA Input (Loop Break)* on page 57.

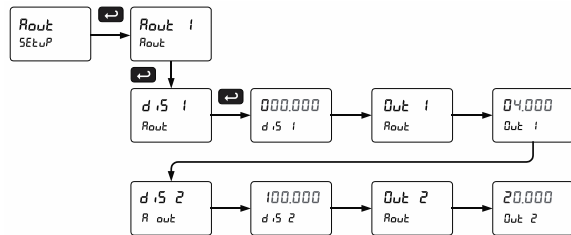

Reset Menu (rESEt)

The *Reset* menu is used to reset the maximum or minimum reading (peak or valley) reached by the process; both may be reset at the same time by selecting “reset high & low” (rSEt HL). The tare value used to zero the display may be reset by selecting “reset tare” (rSEt tr).

Manual Control Menu (Control)

The *Manual Control* menu is used to control the 4-20 mA analog output and the relays manually, ignoring the input. Each relay and analog output can be programmed independently for manual control. Selecting automatic control sets all relays and analog output for automatic operation.

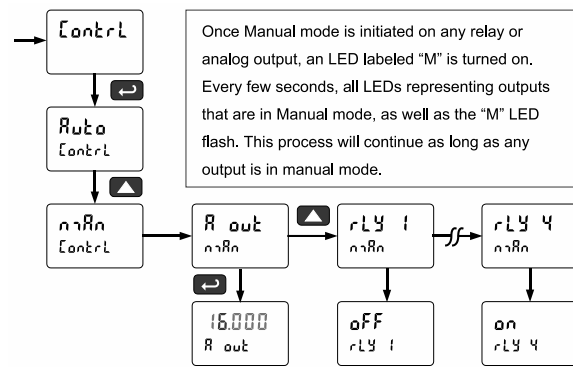

Setting Up the Password (PR55)

The *Password* menu is used for programming three levels of security to prevent unauthorized changes to the programmed parameter settings.

- Pass 1: Allows use of function keys and digital inputs
- Pass 2: Allows use of function keys, digital inputs and editing set/reset points
- Pass 3: Restricts all programming, function keys, and digital input

Protecting or Locking the Meter

Enter the *Password* menu and program a six-digit password.

For instructions on how to program numeric values see *Setting Numeric Values* on page 37.

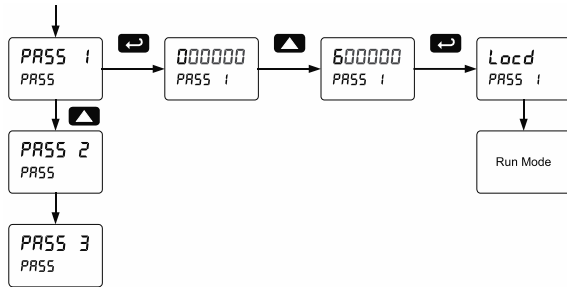

Making Changes to a Password Protected Meter

If the meter is password protected, the meter will display the message *Locd* (*Locked*) when the Menu button is pressed. Press the Enter button while the message is being displayed and enter the correct password to gain access to the menu. After exiting the programming mode, the meter returns to its password protected condition.

Disabling Password Protection

To disable the password protection, access the *Password* menu and enter the correct password twice, as shown below. The meter is now unprotected until a new password is entered.

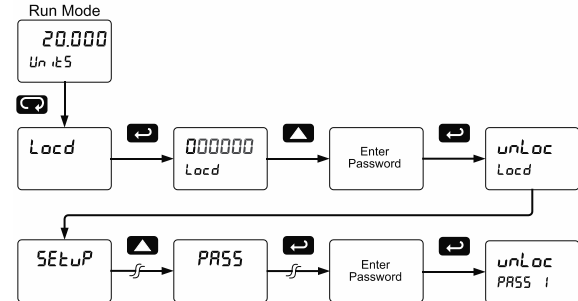

If the correct six-digit password is entered, the meter displays the message *unLoc* (*unlocked*) and the protection is disabled until a new password is programmed.

If the password entered is incorrect, the meter displays the message *Locd* (*Locked*) for about two seconds, and then it returns to Run Mode. To try again, press Enter while the *Locked* message is displayed.

Did you forget the password?

The password may be disabled by entering a master password once. If you are authorized to make changes, enter the master password 508655 to unlock the meter.

Advanced Features Menu

To simplify the setup process, functions not needed for most applications are located in the *Advanced Features* menu.

Press and hold the Menu button for three seconds to access the advanced features of the meter.

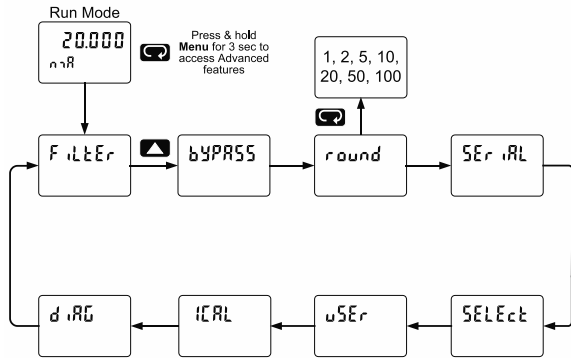

Advanced Features Menu & Display Messages

The following table shows the functions and messages of the *Advanced Features* menu in the order they appear in the menu.

Advanced Features Menu & Display Messages		
Display	Parameter	Action/Setting
F i l t e r	Filter	Set noise filter value
ƒ h - R	Channel A	Set filter value for channel A
ƒ h - b	Channel B	Set filter value for channel B
b Y P A S S	Bypass	Set filter bypass value
ƒ h - R	Channel A	Set filter bypass value for channel A
ƒ h - b	Channel B	Set filter bypass value for channel B
r o u n d	Round	Set the rounding value for display variables
S E r I A L	Serial	Set serial communication parameters
S l a v e I d	Slave ID	Set slave ID or meter address
b a u d	Baud rate	Select baud rate
t r a n s m i t	Transmit delay	Set transmit delay for serial communication
p a r i t y	Parity	Select parity Even, Odd, or None with 1 or 2 stop bits
t - b y t e	Time byte	Set byte-to-byte timeout
S E L E c t	Select	Enter the Select menu (function, cutoff, out)
F u n c t i o n	Input signal conditioning	Select linear, square root, programmable exponent, or round horizontal tank
ƒ h - R	Channel A	Select menu for channel A

Advanced Features Menu & Display Messages		
Display	Parameter	Action/Setting
ƒ h - b	Channel B	Select menu for channel B
L i n e a r	Linear	Set meter for linear function and select number of linearization points
n o P o i n t s	Number of points	Set the number of linearization points (default: 2)
S q u a r e	Square root	Set meter for square root extraction
P r o g r a m m a b l e	Programmable exponent	Set meter for programmable exponent and enter exponent value
r o u n d	Round horizontal tank	Set meter for round horizontal tank volume calculation
L e n g t h	Length	Enter the tank's length in inches
d i a m e t e r	Diameter	Enter the tank's diameter in inches
m a t h	Math	Enter the setup menu for channel C math functions
S u m	Sum	Channel C = (A+B+P)*F
d i f f e r e n c e	Difference	Channel C = (A-B+P)*F
a b s o l u t e	Absolute difference	Channel C = ((Absolute value of (A-B))+P)*F
A v e r a g e	Average	Channel C = (((A+B)/2)+P)*F
m u l t i p l y	Multiplication	Channel C = ((A*B)+P)*F
d i v i d e	Divide	Channel C = ((A/B)+P)*F
H i g h	Max of A or B	C = ((High value of channel A or B)+P)*F
L o w	Min of A or B	C = ((Low value of channel A or B)+P)*F
d r a w	Draw	Channel C = ((A/B)-1)*F
w e i g h t e d	Weighted avg.	Channel C = ((B-A)*F)+A
r a t i o	Ratio	Channel C = (A/B)*F
r a t i o 2	Ratio 2	C = ((B-A)/A)+P)*F
c o n c e n t r a t i o n	Concentration	Channel C = (A/(A+B))*F
c o n s t a n t	Constant	Constant used in channel C math
a d d e r	Adder	Addition constant used in channel C math calculations (P)
f a c t o r	Factor	Multiplication constant used in channel C math calculations (F)
c u t o f f	Cutoff	Set low-flow cutoff
ƒ h - R	Channel A	Set low-flow cutoff for Channel A
ƒ h - b	Channel B	Set low-flow cutoff for Channel B
a n a l o g	Analog output	Program analog output

Advanced Features Menu & Display Messages		
Display	Parameter	Action/Setting
	<i>programming</i>	parameters
Output	<i>Analog output</i>	Program analog output 1 parameters
Source	<i>Source</i>	Select source for the 4-20 mA output
Break	<i>Loop break</i>	Set analog output value if input loop break is detected
Overrange	<i>Overrange</i>	Program mA output for display overrange
Underrange	<i>Underrange</i>	Program mA output for display underrange
Maximum	<i>Maximum</i>	Program maximum mA output allowed
Minimum	<i>Minimum</i>	Program minimum mA output allowed
Calibrate	<i>Calibrate</i>	Calibrate 4-20 mA output (internal reference source used for scaling the output)
4 mA output	<i>4 mA output</i>	Enter mA output value read by milliamp meter with at least 0.001 mA resolution
20 mA output	<i>20 mA output</i>	Enter mA output value read by milliamp meter with at least 0.001 mA resolution
User I/O	<i>User I/O</i>	Assign function keys and digital I/O
F1	<i>F1* function key</i>	Assign F1 function key (*F1/F2/F3)
F4	<i>F4 function</i>	Assign F4 function (digital input)
Digital input 1	<i>Digital input 1</i>	Assign digital input 1 – 4
Digital output 1	<i>Digital output 1</i>	Assign digital output 1 – 4
Internal calibration	<i>Internal calibration</i>	Enter internal calibration (used for recalibrating the meter with a calibrated signal source)
Channel A	<i>Channel A</i>	Perform calibration on channel A
Channel B	<i>Channel B</i>	Perform calibration on channel B
Current calibration	<i>Current calibration</i>	Calibrate 4-20 mA current input (internal reference source used for scaling the input)
Current low	<i>Current low</i>	Calibrate low current input (e.g. 4 mA)
Current high	<i>Current high</i>	Calibrate high current input (e.g. 20 mA)
Voltage calibration	<i>Voltage calibration</i>	Calibrate voltage input
Voltage low	<i>Voltage low</i>	Calibrate low voltage input (e.g. 0 V)
Voltage high	<i>Voltage high</i>	Calibrate high voltage input

Advanced Features Menu & Display Messages		
Display	Parameter	Action/Setting
		(e.g. 10 V)
Diagnostics	<i>Diagnostics</i>	Display parameter settings
LED test	<i>LED test</i>	Test all LEDs
Info	<i>Information</i>	Display software number and version

Noise Filter (Filter)

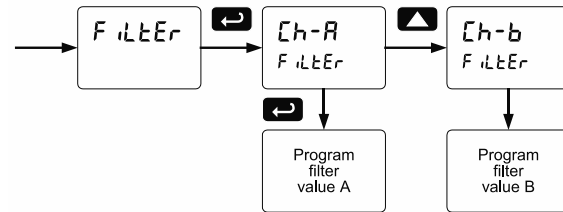

The noise filter is available for unusually noisy signals that cause an unstable process variable display. The noise filter averages the input signal over a certain period. The filter level determines the length of time over which the signal is averaged. The filter level can be set between 2 and 199. The higher the filter level, the longer the averaging time and so the longer it takes the display to settle to its final value. Setting the filter level to zero disables the filter function.

Noise Filter Bypass (bypass)

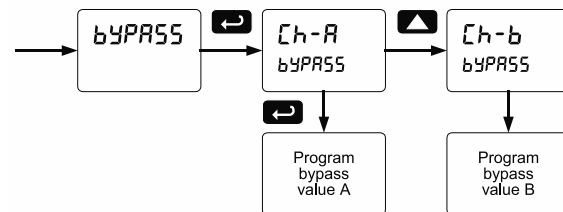

The noise filter bypass changes the behavior of the meter so that small variations in the signal are filtered out but large abrupt changes in the input signal are displayed immediately. The bypass value determines the minimum amount of signal change to be displayed immediately. All signal changes smaller than the bypass value are filtered or averaged by the meter. The noise filter bypass may be set between 0.1 and 99.9% of full scale.

Rounding Feature (round)

The rounding feature is used to give the user a steadier display with fluctuating signals. Rounding is used in addition to the filter function.

Rounding causes the display to round to the nearest value according to the rounding selected. See examples below:

Rounding Selection	Actual Value	Display Value	Actual Value	Display Value
1	12.022	12.022	12.023	12.023
5	12.022	12.020	12.023	12.025
10	12.024	12.020	12.025	12.030

Modbus® RTU Serial Communications (SERIAL)

The meter is equipped with serial communications capability as a standard feature using Modbus® RTU Serial Communication Protocol.

The meter may be connected to a PC for initial configuration via the on-board USB connection. For ongoing digital communications with a computer or other data terminal equipment, use the RS-485 connection.

CAUTION

- **DO NOT** connect any equipment to the RJ45 M-LINK connector. Otherwise damage will occur to the equipment and the meter.
- **DO NOT** disconnect the RJ45 connector located to the left of the power terminal block. Doing so will disable the on-board digital I/O, and the RS-485 serial communications.

Notes:

1. Refer to the ProtEX-MAX Modbus® Register Tables located at www.prediq.com for details.
2. Changes made to the Serial menu are initialized after the menu key is pressed or after navigating through the remainder of the serial parameters (i.e. pass the t-byte parameter).

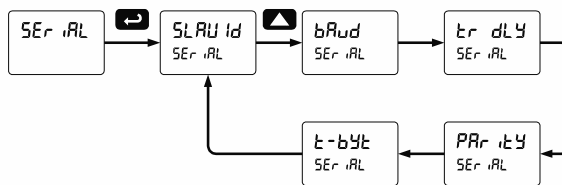

When using more than one meter in a multi-drop mode, each meter must be provided with its own unique address. The meter address (Slave ID) may be programmed between 1 and 247. The transmit delay may be set between 0 and 199 ms. The parity can be set to even, odd, or none with 1 or 2 stop bits.

Select Menu (SELECT)

The Select menu is used to select the input signal conditioning function applied to the inputs (linear, square root, programmable exponent, or round horizontal tank), math function for A & B, constants, low-flow cutoff, and analog output programming. Multi-point linearization is part of the linear function selection.

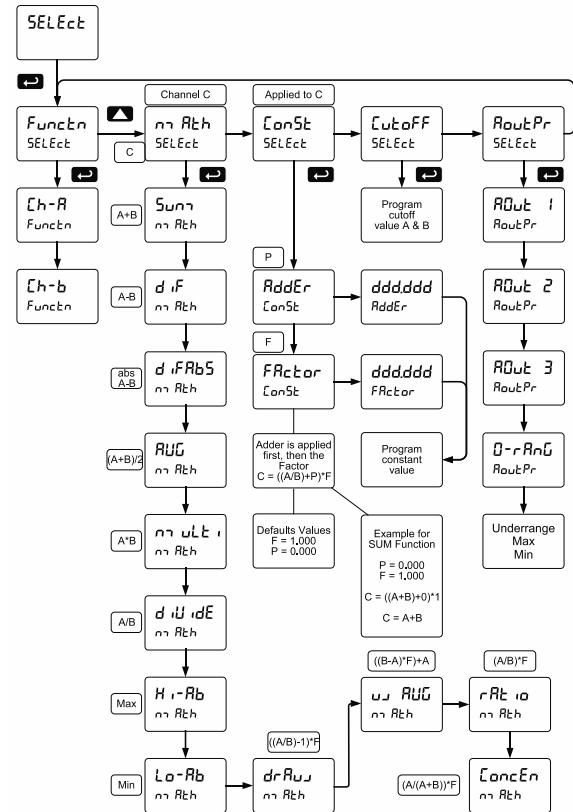

Input Signal Conditioning (Function)

The Function menu is used to select the input-to-output transfer function applied to the input signal: linear, square root, programmable exponent, or round horizontal tank volume calculation. Multi-point linearization is part of the linear function selection.

Meters are set up at the factory for linear function with 2-point linearization. The linear function provides a display that is linear with respect to the input signal.

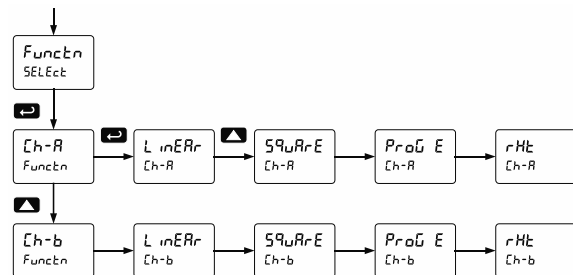

Square Root Linearization (SQR)

The square root function is used to calculate flow measured with a differential pressure transmitter. The flow rate is proportional to the square root of the differential pressure. Scale the meter so that the low input signal (e.g. 4 mA) is equal to zero flow and the high input signal (e.g. 20 mA) is equal to the maximum flow.

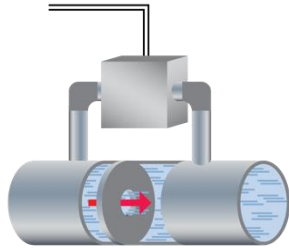

Programmable Exponent Linearization (PEL)

The programmable exponent function is used to calculate open-channel flow measured with a level transmitter in weirs and flumes. The flow rate is proportional to the head height. Scale the meter so that the low input signal (e.g. 4 mA) is equal to zero flow and the high input signal (e.g. 20 mA) is equal to the maximum flow. This method works well for all weirs and flumes that have a simple exponent in the flow calculation formula. For weirs and flumes with complex exponents it is necessary to use a strapping table and the 32-point linearization of the meter. For more information on how the Programmable Exponent Linearization feature works, see the [PD8-6262](#) manual.

Multi-Point Linearization (ML)

Meters are set up at the factory for linear function with 2-point linearization. Up to 32 linearization points can be selected for each channel under the linear function. The multi-point linearization can be used to linearize the display for non-linear signals such as those from level transmitters used to measure volume in odd-shaped tanks or to convert level to flow using weirs and flumes with complex exponent

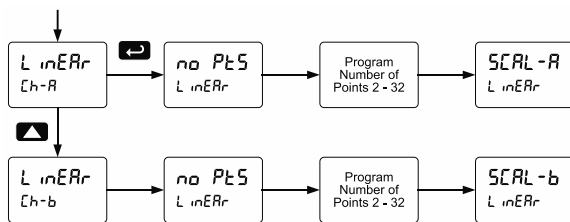

32-Point Linearization

The most common way to linearize a non-linear signal is to break it up into smaller ranges that are more linear than the overall range. The ProtEX-MAX is available with up to 32 points of linearization for each channel. The linearization data can be imported from an Excel spreadsheet or can be exported from MeterView Pro to an Excel spreadsheet.

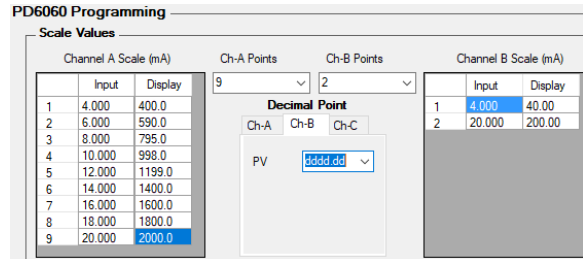

The above graphic illustrates Channel A input being linearized with nine scaling points and Channel B using the more standard two-point scaling method.

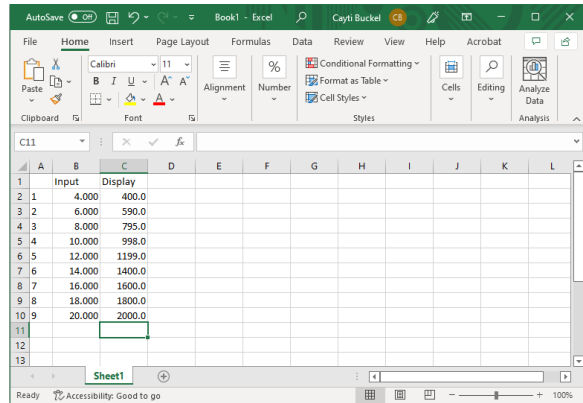

Note: Scale values can also be imported from an Excel spreadsheet.

Round Horizontal Tank Linearization (rHt)

This function automatically calculates the volume in a round horizontal tank with flat ends.

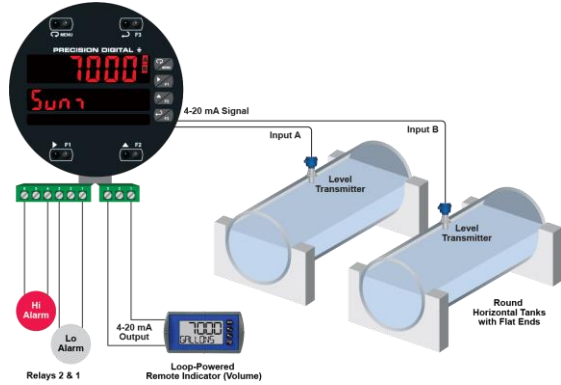

The volume is calculated based on the diameter and length of the tank. The tank's dimensions can be entered in inches or centimeters; the meter automatically calculates the volume in gallons or liters. After entering the dimensions, complete the scaling process with the display values calculated by the meter. The meter can be re-scaled to display the volume in any engineering unit without the need to re-enter the dimensions again.

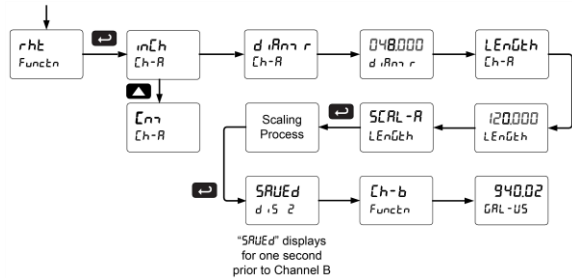

Note: After Scale is displayed continue pressing the Enter button until the meter completes the scaling of the input and display values.

Changing the Volume from Gallons to Liters

In the graphic above, entering 48" for the diameter and 120" for the length of the round horizontal tank, the meter automatically calculates that the volume of the tank is 940.02 gallons.

1. Convert gallons to liters
1 US gallon = 3.7854 L
940.02 gal = 3558.4 L
2. Go to the *Setup* menu and change the decimal point to 1 decimal.
3. Go to the *Program – Scale* menu and press Enter until d, S 2 is shown on the main display.
4. Press Enter and change display 2 value to 3558.4.
5. The meter is now displaying the volume in liters.

Note: The display can be scaled to display the volume in any engineering units.

Another way to display the volume in liters is to enter the dimensions in cm. The meter automatically calculates the volume in liters.

Math Function (nRtH)

The *Math* menu is used to select the math function that will determine the channel C value. These math functions are a combination of input channels A and B, and will display when channel C is selected in the *Display* menu.

The following math functions are available.

Name	Function	Setting
Addition	$(A+B+P)*F$	5000
Difference	$(A-B+P)*F$	d F
Absolute diff.	$((Abs(A-B))+P)*F$	d F RB5
Average	$((A+B)/2+P)*F$	RB5
Multiplication	$((A*B)+P)*F$	n Rb L
Division	$((A/B)+P)*F$	d u dE
Max of A or B	$((AB-Hi)+P)*F$	H i - RB
Min of A or B	$((AB-Lo)+P)*F$	L o - RB
Draw	$((A/B)-1)*F$	d r RB
Weighted avg.	$((B-A)*F)+A$	u j RB
Ratio	$(A/B)*F$	r Rt u
Ratio 2	$((B-A)/A+P)*F$	r Rt u 2
Concentration	$(A/(A+B))*F$	L o n E n

Math Constants (L0n5t)

The *Math Constants* menu is used to set the constants used in channel C math. The math functions include input channel A and B, as well as the adder constant P, and factor constant F.

The *Adder* constant (P) may be set from -99.999 to 999.999.

The *Factor* constant (F) may be set from 0.001 to 999.999.

The *Math Function (nRtH)* chart above details the math functions that may be selected in the *Math Functions* menu.

Low-Flow Cutoff (L0t0FF)

The low-flow cutoff feature allows the meter to be programmed so that the often-unsteady output from a differential pressure transmitter, at low flow rates, always displays zero on the meter.

The cutoff value may be programmed from 0.1 to 999999. The meter will display zero below the cutoff value. Programming the cutoff value to zero disables the cutoff feature. The cutoff can be disabled to display negative values.

Analog Output Programming (RoutPr)

The *Analog Output Programming* menu is used to program the behavior of the 4-20 mA output. The following parameters and functions are programmed in this menu:

1. Source: Source for generating the 4-20 mA output
2. Overrange: Analog output value with display in overrange condition
3. Underrange: Analog output value with display in underrange condition
4. Break: Analog output value when loop break is detected
5. Max: Maximum analog output value allowed regardless of input
6. Min: Minimum analog output value allowed regardless of input
7. Calibrate: Calibrate the internal 4-20 mA source reference used to scale the 4-20 mA output

Analog Output Source

The analog output source can be based on either of the input channels (Ch-A, Ch-B), the math channel (Ch-C), maximum stored value of either input channel (Hi-A, Hi-B), minimum stored value of either input channel (Lo-A, Lo-B), relay set points, or the Modbus® input.

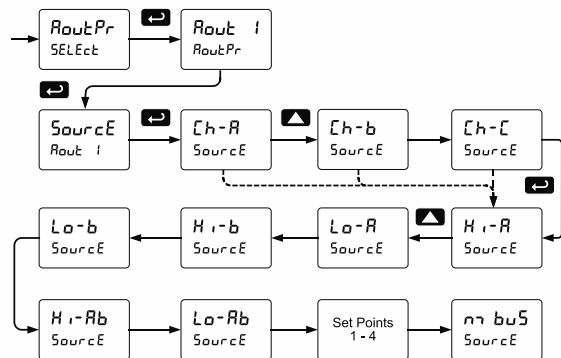

Analog Output Value for Loss of 4-20 mA Input (Loop Break)

The *RoutPr - Break* menu is used to force the analog output to go to a user-specified mA value if a break condition is detected in the 4-20 mA input loop. Selecting Ignore causes the mA output to go to the minimum value.

Analog Output Calibration

To perform the analog output calibration, it is recommended to use a milliamp meter with a resolution of at least 0.1 µA to measure the output current. The values saved internally during this procedure are used for scaling the 4-20 mA output in the *Setup* menu.

Analog Output Calibration Procedure

1. Wire the PD8-6060 4-20 mA output to a current loop that includes a power supply (internal or external 12 to 24 VDC), and the mA input on the digital meter. See *Figure 18. 4-20 mA Output Connections* on page 31 for details.
2. Turn on all devices. Allow for a 15 to 30 minute warm-up.
3. Go to the Advanced Features menu, navigate to Select (SELEct) and choose Analog Output Programming (RoutPr) → Calibration (CALib) menu and press **Enter**.
4. The display will show 4 mAR. The PD8-6060 mA output should now be close to 4 mA. Press Enter and the display will show 04.000. Enter the actual value read by the digital mA meter and press **Enter**.
5. The display will show 20 mAR. The PD8-6060 mA output should now be close to 20 mA. Press **Enter** and the display will show 20.000. Enter the actual value read by the digital mA meter and press **Enter**.
6. The meter will now calculate the calibration factors and store them.
7. Press **Menu** to exit and return to Run mode.

Programmable Function Keys User Menu (uSEr)

The *User* menu allows the user to assign the front programming buttons function keys F1, F2, and F3, the digital input F4 (located on the input signal connector), and four digital inputs (located on the digital I/O connector) to access most of the menus or to activate certain functions immediately (e.g. reset max & min, hold relay states, etc.). This allows the meter to be greatly customized for use in specialized applications.

The four digital outputs can be assigned to a number of actions and functions executed by the meter (i.e. alarms, relay acknowledgement, reset max, min, or max & min, tare, and reset tare). The digital outputs can be used to trigger external alarms or lights to indicate these specific events.

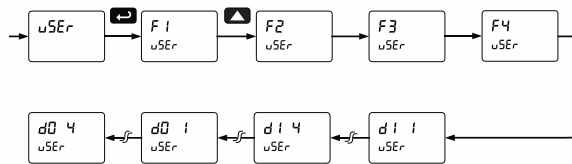

Function Keys & Digital I/O Available Settings

Refer to the following table for descriptions of each available function key or digital I/O setting.

Display	Description
r 5t H i	Reset the stored maximum display values for all channels
r 5t Lo	Reset the stored minimum display values for all channels
r 5t H L	Reset the stored maximum & minimum display values for all channels
t R r E A	Capture tare and zero the display for channel A (A LED flashes – same rate as M)**
t R r E b	Capture tare and zero the display for channel B (B LED flashes – same rate as M)**
r 5t t r	Reset captured tare and resume normal operation for both channels A & B
r E L R Y	Directly access the relay menu
5 E t i *	Directly access the set point menu for relay 1 (*through 4)
r L Y d	Disable all relays until a button assigned to <i>enable relays</i> (r L Y E) is pressed
r L Y E	Enable all relays to function as they have been programmed
H o L d	Hold current relay states and analog output as they are until a button assigned to <i>enable relays</i> (r L Y E) is pressed

Display	Description
d H o L d	Hold the current display value, relay states, and analog output momentarily while the function key or digital input is active. The process value will continue to be calculated in the background.
d R b C	Scrolls values for A, B & C when activated. Keeps the last value for 10 seconds and then it returns to its assignment. Values are displayed on display line 1 and the corresponding channel and units on display line 2.
L n 1 H i	Display maximum channel A display value on line 1
L n 1 Lo	Display minimum channel A display value on line 1
L n 1 H L	Display maximum & minimum channel A display values on line 1
L n 2 H i	Display maximum channel B display value on line 2
L n 2 Lo	Display minimum Channel B display value on line 2
L n 2 H L	Display maximum & minimum channel B display values on line 2
L 3 H L C	Display maximum channel C display value on line 2
L n 2 H C	Display minimum channel C display value on line 2
L n 2 H C	Display maximum & minimum channel C display values on line 2
F O n i *	Force relay 1 (*through 4) into the on state. This function is used in conjunction with a digital input to achieve interlock functionality. See <i>Setting Up the Interlock Relay (Force On) Feature</i> on page 49 for details.
C o n t r L	Directly access the control menu
d i S A b L	Disable the selected function key or digital I/O
R c H	Acknowledge all active relays that are in a manual operation mode such as auto-manual or latching
r E 5 E t	Directly access the reset menu
n r E n u	Mimic the menu button functionality (digital inputs only)
r i G H t	Mimic the right arrow/F1 button functionality (digital inputs only)
u P	Mimic the up arrow/F2 button functionality (digital inputs only)
E n t E r	Mimic the enter/F3 button functionality (digital inputs only)
R L n r i *	Provide indication when alarm 1 (*through 4) has been triggered (digital outputs only)

** If math functions are displayed, the math function indicator LED “C” will flash when either A or B channel is using a tare value (net value).

Tare (tARE)

The tare function zero's out the display. In the case of scale weight, tare is used to eliminate container weight and provide net weight readings. There are two tare functions; Capture Tare for channel A and B, and Reset Tare. Display channel indicator letter flashes when a tare is used. It will flash until the tare is reset. The tare can be reset via the Reset menu, a function key, or a digital input.

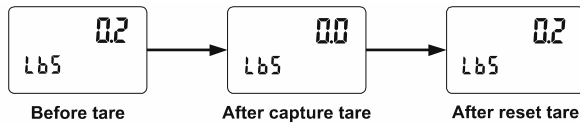

Gross (without tare) and net (with tare) values can be viewed simultaneously. See *Setting the Display Parameter & Intensity (dSPLR)* on page 41.

Internal Calibration (ICRL)

The meter is **factory calibrated** prior to shipment for milliamps and volts with calibration equipment that is certified to NIST standards.

The use of calibrated signal sources is necessary to perform the internal calibration of the meter.

Check calibration of the meter at least every 12 months. Each input and input type must be recalibrated separately.

Notes:

1. If meter is in operation and it is intended to accept only one input type (e.g. 4-20 mA), recalibration of other input is not necessary.
2. Allow the meter to warm up for at least 15 minutes before performing the internal calibration procedure.

The *Internal calibration* menu is part of the *Advanced Features* menu.

1. Press and hold the Menu button for three seconds to access the advanced features of the meter.
2. Press the Up arrow button to scroll to the *Internal calibration* menu (ICRL) and press Enter.
3. Select channel A (Ch-A) or channel B (Ch-b) and press enter.
4. The meter displays either current calibration (ICRL) or voltage calibration (IVRL), according to the input setup. Press Enter to start the calibration process.

Example of Internal Calibration for current input:

5. The meter displays *low* input current message (CLo). Apply the low input signal and press Enter. The display flashes for a moment while the meter is accepting the low input signal.
6. After the display stops flashing, a number is displayed with the leftmost digit brighter than the rest. The bright digit is the active digit that can be changed by pressing the Up arrow button. Press the Right arrow button to move to the next digit.

7. Set the display value to correspond to the input signal being calibrated, typically 4.000 mA.
8. The display moves to the *high* input calibration (CHi). Apply the high input signal and press Enter.
9. Set the display for the high input calibration, in the same way as it was set for the low input calibration, typically 20.000 mA.

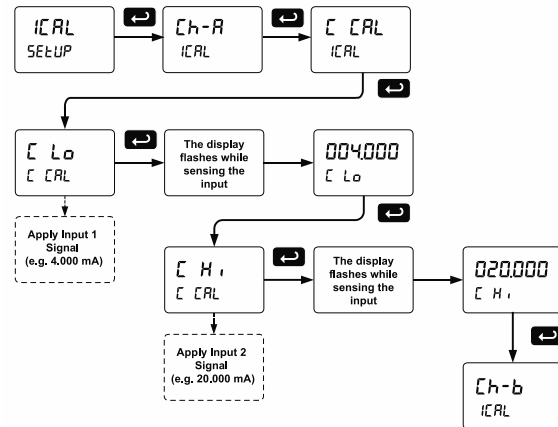

The graphic shows the calibration of the current input. The voltage input is calibrated in a similar way.

Tips:

- Low and high input signals can be any valid values within the range of the meter.
- Observe minimum input span requirements between input 1 and input 2.
- Low input should be less than high input signal.

Error Message (Error)

An error message indicates that the calibration or scaling process was not successful.

After the error message is displayed, the meter reverts to the input prior to the failure during calibration or scaling and to input 1 during internal calibration, allowing the appropriate input signal to be applied or programmed.

The error message might be caused by any of the following conditions:

1. Input signal is not connected to the proper terminals or it is connected backwards*.
2. Wrong signal selection in *Setup* menu*.
3. Minimum input span requirements not maintained.
4. Input 1 signal inadvertently applied to calibrate input 2*.

*Not relevant when scaling the meter.

Meter Operation

When installed, the primary way to operate the meter is with the SafeTouch through-glass buttons that allow the user to perform various operations without removing the cover and exposing the electronics to the hazardous environment. The user can also operate the meter by connecting a suitable control station or switch to one of the digital inputs that can be used to perform various operations on the meter based on the Programmable Function Keys. Finally, certain operations can be performed on the meter with MeterView Pro software or through Modbus® commands.









The two default operations that can be performed with the meter's SafeTouch buttons are:

1. Display the maximum and minimum readings
2. Acknowledge the relays

In addition, the user can program the SafeTouch Buttons to perform a variety of useful operations by reassigning them to other functions per *Function Keys & Digital I/O Available Settings* on page 58.

Button Operation

The following table shows the default operations for the F1, F2, and F3 SafeTouch Buttons, Displaying and resetting the maximum and minimum values and resetting the relays:

Button Symbol	Description
 	Press to enter or exit Programming Mode, view settings, or exit max/min readings
 	Press to reset max/min readings or other parameter/function assigned through the <i>User</i> menu
 	Press to display max/min readings or other parameter/function assigned through the <i>User</i> menu
 	Press to acknowledge relays or other parameters/function assigned through the <i>User</i> menu



To learn more about SafeTouch buttons, see this video: predig.com/videos/Safetouch_Buttons

SafeTouch Buttons

The ProtEX-MAX is equipped with four sensors that operate as through-glass buttons so that it can be programmed and operated without removing the cover (and exposing the electronics) in a hazardous area.

These buttons can be disabled for security by selecting DISABLE on the switch labeled NO-CONTACT BUTTONS located on the connector board.



To actuate a button, press one finger to the glass directly over the marked button area. Then retract finger more than three inches from the glass before pressing the next button. When the cover is removed, the four mechanical buttons located next to the sensors are used. The sensors are disabled when a mechanical button is pressed and will automatically be re-enabled after 60 seconds of inactivity.

The SafeTouch Buttons are designed to filter normal levels of ambient interference and to protect against false triggering, however, it is recommended that the SafeTouch Buttons be disabled (slide switch to DISABLE) if there is an infrared interference source in line-of-sight to the display.

The SafeTouch Buttons are configured by default to duplicate the function of the front panel mechanical pushbuttons associated with the integrated meter. The symbols by each SafeTouch button correspond to a mechanical button as shown in the above table.

SafeTouch Button Tips:

- To the extent possible, install the display facing away from sunlight, windows, reflective objects, and any sources of infrared interference.
- Keep the glass window clean.
- Tighten the cover securely.
- Use a password to prevent tampering.

Function Keys Operation

During operation, the programmable function keys operate according to the way they have been programmed in the *Advanced Features – User* menu. See *Programmable Function Keys User Menu (u5Er)* on page 58 for details.

The Meter Operation

When installed, the primary way to operate the meter is with the SafeTouch through-glass buttons that allow the user to perform various operations without removing the cover and exposing the electronics to the hazardous environment. The user can also operate the meter by connecting a suitable control station or switch to one of the digital inputs that can be used to perform various operations on the meter based on the Programmable Function Keys. Finally, certain operations can be performed on the meter with MeterView Pro software or through Modbus® commands.

The two default operations that can be performed with the meter's SafeTouch buttons are:

1. Display the maximum and minimum readings
2. Acknowledge the relays

In addition, the user can program the SafeTouch Buttons to perform a variety of useful operations by reassigning them to other functions per *Function Keys & Digital I/O Available Settings* on page 58.

Button Operation table on page 60 shows the factory default settings for F1, F2, and F3.

Digital Inputs Operation

Five (5) digital inputs, F4, DI-1 to DI-4, come standard on the meter. These digital inputs are programmed identically to function keys F1, F2, and F3. The inputs are triggered with a contact closure to +5 in the case of digital inputs 1-4 or with an active high signal, see *Digital I/O Connections* on page 31 for details. The F4 is triggered with a contact closure to COM or with an active low signal. During operation, digital inputs operate according to the way they are programmed in the *Advanced Features – User* menu. See *Programmable Function Keys User Menu (u5Er)* on page 58 for details.

Maximum/Minimum Readings

The max & min readings (peak & valley) reached by the process can be displayed either continuously or momentary:

1. Display briefly by assigning to the F1-F3 function keys or to the digital inputs in the *User* menu.
2. Display continuously by assigning either display to max/min through the *Display* menu.

Any of the F1-F3 function keys (buttons) and the digital inputs can be programmed to reset the max & min readings. The meters are set at the factory to display the max reading by pressing the Up arrow/F2 button and to use the Right arrow/F1 button to access the *Reset* menu.

To display max and min channel A reading using function key with factory defaults:

1. Press Up arrow/F2 button to display minimum reading of channel A since the last reset/power-up. The display will then display the maximum reading of channel A since the last reset/power-up.
2. Press the Up arrow/F2 button again to display the minimum reading of channel A since the last reset/power up.
3. To reset max/min press Right arrow/F1 button to access the *Reset* menu. The max & min displays are reset to actual values.

Press Menu to exit max/min display reading.

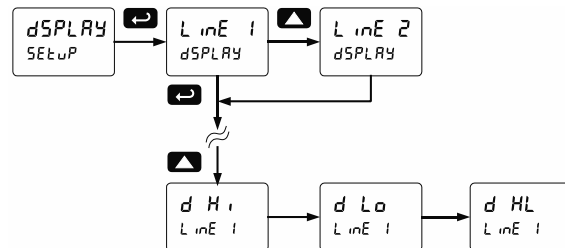

Troubleshooting

The rugged design and the user-friendly interface of the meter should make it unusual for the installer or operator to refer to this section of the manual. However, due to the many features and functions of the meter, it's possible that the setup of the meter does not agree with what an operator expects to see.

If the meter is not working as expected, refer to the *Diagnostics* menu and recommendations below.

Diagnostics Menu (d ,RŁ)

The *Diagnostics* menu is located in the *Advanced Features* menu, to access *Diagnostics* menu see *Advanced Features Menu* on page 52.

This menu allows the user to test the functionality of all the meter LEDs, check the meter's software and version information, and erase the MeterView Pro software installation files from the meter. Press the Enter button to view the settings and the Menu button to exit at any time.

For a description of the diagnostic messages, see *Advanced Features Menu & Display Messages* on page 52.

Testing the Display LEDs

To test all LEDs on the display:

1. Go to the *Diagnostics* menu (d ,RŁ) and press Enter button.
2. Press Up arrow button and scroll to *LED Test* menu (LŁd Ł).
3. Press the Enter button to activate the LED Test. The meter will cycle through all digits, decimal points, and relay indicators to enable the operator to check that all LEDs are functioning properly.
4. Press the Enter button again to access the *Information* menu (,nFŁ) or press the Menu button to return to Run Mode.

Determining Software Version

To determine the software version of a meter:

1. Go to the *Diagnostics* menu (d ,RŁ) and press Enter button.
2. Press Up arrow button and scroll to *Information* menu (,nFŁ).
3. Press Enter to access the software number (5FŁ) and version (WŁr) information. Write down the information as it is displayed. Continue pressing Enter until all the information is displayed.
4. The meter returns to Run Mode after displaying all the settings.

Reset Meter to Factory Defaults

When the parameters have been changed in a way that is difficult to determine what's happening, it might be better to start the setup process from the factory defaults.

Instructions to load factory defaults:

1. Enter the *Advanced Features* menu. See *Advanced Features Menu* on page 52.
2. Press Up arrow to go to *Diagnostics* (d ,RŁ) menu
3. Press and hold Right arrow for three seconds, press Enter when display flashes rŁŁŁŁ.
4. The meter goes through an initialization sequence (similar as on power-up), and loads the factory default settings.

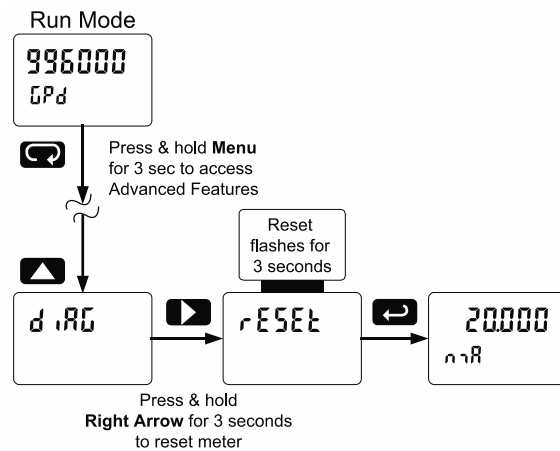

Factory Defaults & User Settings

The following table shows the factory setting for most of the programmable parameters on the meter.

Factory Defaults & User Settings		
Parameter	Display	Default Setting
Input type	inPut	
Input type, channel A	[h-R	4-20 mA
Input type, channel B	[h-b	4-20 mA
Unit	unit	
Unit, channel A	[h-R	mA-A
Unit, channel B	[h-b	mA-b
Unit, channel C	[h-[-	mA-C
Number of points	no Pts	
Number of points, ch A	[h-R	2
Number of points, ch B	[h-b	2
Scaling, (channel A)	ScAL R	
Input 1, channel A	inP 1	4.000 mA
Display 1, channel A	d 15 1	4.000
Input 2, channel A	inP 2	20.000 mA
Display 2, channel A	d 15 2	20.000
Scaling (channel B)	ScAL b	
Input 1, channel B	inP 1	4.000 mA
Display 1, channel B	d 15 1	4.000
Input 2, channel B	inP 2	20.000 mA
Display 2, channel B	d 15 2	20.000
Math, channel C	Sum	Sum
Adder (constant P)	AddEr	0.000
Factor (constant F)	FActoR	1
Filter	FiLTER	
Filter, channel A	[h-R	70
Filter, channel B	[h-b	70
Bypass, channel A	bYPASS	0.2
Bypass, channel B	bYPASS	0.2
Round	round	1
Cutoff	CuTOff	
Cutoff value, channel A	[h-R	0.0 (disabled)
Cutoff value, channel B	[h-b	0.0 (disabled)
Display assignment	dSPLY	
Display line 1	d [h-R	Channel A
Display line 2	d [h-b	Channel B
Display intensity	d-IntY	6
Relay 1 assignment	[h-R	Channel A
Relay 1 action	Rct 1	Automatic
Relay 1 set point	SEt 1	1.000
Relay 1 reset point	rSEt 1	0.500
Relay 2 assignment	[h-R	Channel A

Factory Defaults & User Settings

Parameter	Display	Default Setting
Relay 2 action	Rct 2	Automatic
Relay 2 set point	SEt 2	2.000
Relay 2 reset point	rSEt 2	1.500
Relay 3 assignment	[h-R	Channel A
Relay 3 action	Rct 3	Automatic
Relay 3 set point	SEt 3	3.000
Relay 3 reset point	rSEt 3	2.500
Relay 4 assignment	[h-R	Channel A
Relay 4 action	Rct 4	Automatic
Relay 4 set point	SEt 4	4.000
Relay 4 reset point	rSEt 4	3.500
Fail-safe relay 1	FLS 1	Off
Fail-safe relay 2	FLS 2	Off
Fail-safe relay 3	FLS 3	Off
Fail-safe relay 4	FLS 4	Off
On delay relay 1	On 1	0.0 sec
Off delay relay 1	OFF 1	0.0 sec
On delay relay 2	On 2	0.0 sec
Off delay relay 2	OFF 2	0.0 sec
On delay relay 3	On 3	0.0 sec
Off delay relay 3	OFF 3	0.0 sec
On delay relay 4	On 4	0.0 sec
Off delay relay 4	OFF 4	0.0 sec
Loop break relay 1	LnbrE	Ignore
Loop break relay 2	LnbrE	Ignore
Loop break relay 3	LnbrE	Ignore
Loop break relay 4	LnbrE	Ignore
Display 1 analog out	d 15 1	4.000
Output 1 value	Out 1	4.000 mA
Display 2 analog out	d 15 2	20.000
Output 2 value	Out 2	20.000 mA
Source analog output	Source	Channel A
Overrange output	o-rAnG	21.000 mA
Underrange output	u-rAnG	3.000 mA
Loop break output	brERH	3.000 mA
Maximum output	maxH	23.000 mA
Minimum output	min	3.000 mA
Slave ID (Address)	SLRu Id	247
Baud rate	bAud	9600
Transmit delay	tr dLY	50 ms
Parity	PRr lTY	Even
Byte-to-byte timeout	b-bTY	010 (0.1 sec)
F1 function key	F 1	Reset max & min

Factory Defaults & User Settings		
Parameter	Display	Default Setting
F2 function key	F2	Upper Max & Min
F3 function key	F3	Acknowledge relays
F4 function (digital input)	F4	Acknowledge relays
Digital input 1	d 1 1	Menu
Digital input 2	d 1 2	Right arrow
Digital input 3	d 1 3	Up arrow
Digital input 4	d 1 4	Enter
Digital output 1	d0 1	Alarm 1

Factory Defaults & User Settings		
Parameter	Display	Default Setting
Digital output 2	d0 2	Alarm 2
Digital output 3	d0 3	Alarm 3
Digital output 4	d0 4	Alarm 4
Password 1	PR55 1	000000 (unlocked)
Password 2	PR55 2	000000 (unlocked)
Password 3	PR55 3	000000 (unlocked)

Troubleshooting Tips

This meter is a highly sophisticated instrument with an extensive list of features and capabilities. If the programming buttons are used to program the meter, it may be a difficult task to keep everything straight. That is why we strongly recommend the use of the free [MeterView Pro](#) software for all programming activities. A USB cable is provided with the meter for programming with MeterView Pro software.

If you have programmed the meter with the programming buttons and it is not working as intended, try re-programming the meter using MeterView Pro software.

Symptom	Check/Action
No display at all	Check power at power connector
Not able to change setup or programming, LoCd is displayed	Meter is password-protected; enter correct six-digit password to unlock or Master Password of 508655
Meter does not respond to input change	If a <i>Low-Flow Cutoff Value</i> has been programmed, the meter will display zero below that point, regardless of the input – which can appear like the meter is not responding to an input change. Check to make sure the problem is not being caused by an undesired low-flow cutoff value. To prevent the display from showing a negative value, set the low-flow cutoff to a value greater than zero.
Meter displays error message during calibration (Error)	Check: <ol style="list-style-type: none"> 1. Signal connections 2. Input selected in <i>Setup</i> menu 3. Minimum input span requirements
Meter displays <ol style="list-style-type: none"> 1. 999999 2. -999999 	Check: <ol style="list-style-type: none"> 1. Input selected in <i>Setup</i> menu 2. Corresponding signal at Signal connector
Display is unstable	Check: <ol style="list-style-type: none"> 1. Input signal stability and value 2. Display scaling vs. input signal 3. Filter and bypass values (increase)
Display response is too slow	Check filter and bypass values
Display reading is not accurate	Check: <ol style="list-style-type: none"> 1. Input signal conditioner selected: Linear, square root, etc. 2. Scaling or calibration
Display does not respond to input changes, reading a fixed number	Check display assignment, it might be displaying max, min, or set point
Display alternates between <ol style="list-style-type: none"> 1. H and a number 2. Lo and a number 	Press Menu to exit max/min display readings
Relay operation is reversed	Check: <ol style="list-style-type: none"> 1. Fail-safe in <i>Setup</i> menu 2. Wiring of relay contacts
Relay and status LED do not respond to signal	Check: <ol style="list-style-type: none"> 1. Relay action in <i>Setup</i> menu 2. Set and reset points
Flashing relay status LEDs	Relays in manual control mode or relay interlock switches opened
Meter not communicating with application programs	Check: <ol style="list-style-type: none"> 1. M-Link Connector installed between PROVU electronics and ProtEX-MAX connector board. See <i>Figure 4: Integrated PROVU Required Connections</i> on page 27 2. Serial settings 3. Meter address and baud rate
If the display locks up or the meter does not respond at all	Cycle the power to reboot the microprocessor

Troubleshooting Tips

Symptom	Check/Action
SafeTouch buttons do not respond	<ol style="list-style-type: none"> 1. If mechanical button was pushed, the SafeTouch buttons will be re-enabled automatically 60 seconds after the last button push. 2. If slide switch on connector board is in DISABLE position, switch to ENABLE. 3. Strong direct sunlight may interfere with SafeTouch button operation. It is recommended to operate the buttons by standing so as to block direct sunlight.
Serial Communications Power LED Indicator is off	Check: <ol style="list-style-type: none"> 1. Modular cable connection 2. Power to the device
If only the TX (or DATA IN) data status LED is flashing when serial communications attempted	Check: <ol style="list-style-type: none"> 1. Serial cable 2. Protocol selected on device 3. Instrument address & baud rate 4. Program address & baud rate
If both data status LEDs (TX and RX) are off when trying to communicate	Remove all unnecessary cables and instruments from the bus. Try getting the system to work with only one device (to ease troubleshooting) and then expand the system one device at a time.
Communications slow	Increase the baud rate
Random communication errors	<ol style="list-style-type: none"> 1. Increase the TX delay time 2. Decrease the baud rate
Other symptoms not described above	Call Technical Support for assistance

Note: Certain sequences of events can cause unexpected results. To solve these issues, it is best to start fresh from factory defaults and use the manual as a step by step programming guide, rather than a random approach to programming. To reset the meter to factory defaults, see Reset Meter to Factory Defaults on page 62. In addition, for best results, we recommend using the free MeterView Pro software for all programming needs.

Complete Product Line of Displays and Controllers IN ALL SHAPES, SIZES & LOCATIONS



Big, Bright Displays
For Indoor or Outdoor
in Bright Sunlight



Large Dual-Line
6-Digit Display



24 VDC
Transmitter
Power Supply



MeterView® Pro USB
Programming Software



Universal 85-265
VAC or 12-24 VDC
Input Power
Options



4-20 mA, 0-10 V,
Thermocouple, RTD,
Strain Gauge, High
Voltage, & Modbus Inputs



Up To Four
3 A Form C
Relays (SPDT)



FM APPROVED SP Ex CE IECEX

EXPLOSION-PROOF ProtEX-MAX Series

- NEMA 4X, IP68 Rated Enclosure
- SafeTouch® Through-Glass Buttons
- Operating Temperature of -40 to 65°C
- Worldwide Approvals

LARGE DISPLAYS Helios Series

- 1.8" Digits Readable From 100 Feet
- NEMA 4X, IP65 Rated Enclosure
- Operating Temperature of -40 to 65°C
- Now UL and C-UL Approved!

CE .UL

PANEL METERS ProVu Series

- NEMA 4X, IP65 Rated Front
- Programmable Function Keys
- UL, C-UL, and CE Approvals
- 1/8 DIN Size

Go to PREDIG.COM for details on ProVu, ProtEX-MAX and Helios Series Meters

Contact Precision Digital

Technical Support

Call: (800) 610-5239 or (508) 655-7300

Fax: (508) 655-8990

Email: support@predig.com

Sales Support

Call: (800) 343-1001 or (508) 655-7300

Fax: (508) 655-8990

Email: sales@predig.com

Place Orders

Email: orders@predig.com

For the latest version of this manual please visit

www.predig.com

PRECISION DIGITAL CORPORATION

233 South Street • Hopkinton MA 01748 USA

Tel (800) 343-1001 • Fax (508) 655-8990

www.predig.com

