

PD8-6100 Strain Gauge, Load Cell, and mV Meter

Instruction Manual



IECEX

MeterView Pro

USB Install

- Fully-Approved Explosion-Proof Meter
- 15, 30, 150, 300 mV unipolar; ± 15 , ± 25 , ± 150 , ± 250 mV bipolar Inputs
- Dual-Line 6-Digit Display, 0.6" (15 mm) & 0.46" (12 mm)
- Selectable 5 or 10 VDC Sensor Excitation @ 25 mA Max
- SafeTouch Through-Glass Button Programming
- Display Mountable at 0°, 90°, 180°, & 270°
- 4 Relays with Interlocking Capability + Isolated 4-20 mA Output Option
- Free PC-Based, On-Board, MeterView Pro USB Programming Software
- SunBright Display Standard Feature; Great for Outdoor Applications
- Operating Temperature Range: -40 to 60°C (-40 to 140°F)
- FM Approved as Explosion-Proof / Dust-Ignition-Proof / Flame-Proof
- CSA Certified as Explosion-Proof / Dust-Ignition-Proof / Flame-Proof
- ATEX and IECEx Certified as Flame-Proof
- Input Power Options: 85-265 VAC / 90-265 VDC or 12-24 VDC / 12-24 VAC
- Supports One (1) 350 Ω Load Cell
- Capture or Programmable Tare Feature
- Auto-Zero Feature Eliminates Zero Drift
- Ratiometric Operation
- Programmable Display, Function Keys & Digital Inputs
- Flanges for Wall or Pipe Mounting
- Explosion-Proof, IP68, NEMA 4X Die-Cast Aluminum Enclosure
- On-Board RS-485 Serial Communications
- Modbus RTU Communication Protocol Standard
- Password Protection
- Four 3/4" NPT Threaded Conduit Openings (Two Plugs Installed)
- Pipe Mounting Kits
- Stainless Steel Tag Available
- 3-Year Warranty

PRECISION DIGITAL CORPORATION

233 South Street • Hopkinton MA 01748 USA
Tel (800) 343-1001 • Fax (508) 655-8990

www.prediq.com



The Complete **ProtEX™** Series

MAX



PD8-154
**4-Point Alarm
Annunciator**



PD8-6100
Strain Gauge Meter



PD8-158
**8-Point Alarm
Annunciator**



PD8-6200
**Analog Input
Flow Rate/Totalizer**



PD8-765
**Process &
Temperature Meter**



PD8-6210
**Analog Input Batch
Controller**



PD8-6000
Process Meter



PD8-6262
**Analog Dual-Input
Flow Rate/Totalizer**



PD8-6001
**Feet & Inches
Level Meter**



PD8-6300
**Pulse Input
Flow Rate/Totalizer**



PD8-6060
**Dual-Input
Process Meter**



PD8-6310
**Pulse Input
Batch Controller**



PD8-6080
**Modbus® Scanner
with Dual Analog Input**



PD8-6363
**Pulse Dual-Input
Flow Rate/Totalizer**



PD8-6081
**Feet & Inches
Modbus® Scanner**



PD8-7000
Temperature Meter

Go to PREDIG.COM for details on the entire ProtEX-MAX Series Meters

Disclaimer

The information contained in this document is subject to change without notice. Precision Digital makes no representations or warranties with respect to the contents hereof and specifically disclaims any implied warranties of merchantability or fitness for a particular purpose. See Warranty Information and Terms & Conditions on www.prediq.com for complete details.

CAUTION

- Read complete instructions prior to installation and operation of the meter.

WARNINGS

- Risk of electric shock or personal injury.
- This product is not recommended for life support applications or applications where malfunctioning could result in personal injury or property loss. Anyone using this product for such applications does so at his/her own risk. Precision Digital Corporation shall not be held liable for damages resulting from such improper use.
- Failure to follow installation guidelines could result in death or serious injury. Make sure only qualified personnel perform the installation.
- Never remove the meter cover in explosive environments when the circuit is live.
- Cover must be fully engaged to meet explosion-proof/dust-ignition-proof/flame-proof requirements.

WARNING

Cancer and Reproductive Harm - www.P65Warnings.ca.gov

Limited Warranty

Precision Digital Corporation warrants this product against defects in material or workmanship for the specified period under "Specifications" from the date of shipment from the factory. Precision Digital's liability under this limited warranty shall not exceed the purchase value, repair, or replacement of the defective unit. See Warranty Information and Terms & Conditions on www.prediq.com for complete details.

Registered Trademarks

All trademarks mentioned in this document are the property of their respective owners.

© 2022 Precision Digital Corporation.
All rights reserved.

FREE MeterView Pro Programming Software

The meter can be powered from the USB connection. When using the USB connection, **DO NOT** apply AC or DC power to the meter.

The easiest and quickest way to program your ProtEX-MAX meter is to use the FREE MeterView Pro programming software. This software is loaded into the meter and connects and installs directly to your PC with a USB cable. We recommend that the first thing you do after taking the meter out of the box is connect the ProtEX-MAX to your PC with the provided USB cable – do not use a different cable. **DO NOT** apply AC or DC power to the meter while your PC is connected to the meter as it will disrupt the USB connection. You don't even have to apply an input signal.

MeterView Pro programming software is intuitive, and most customers can get their meter programmed as they like without even looking in the manual.

Watch MeterView Pro Software Video at
www.prediq.com/meterviewpro

In addition to programming, the software may be used for:

- Monitoring
- Datalogging using your PC
- Generating and saving programming files for later use

Once your meter is programmed the way you want it, you can wire it up for your application per the instructions in this manual and install it. If you find that you need to make adjustments to the programming after the meter is installed, you can use the programming panel buttons and the instructions in this manual to do so.

WARNING

- When using the USB connection, the meter should only be connected to a computer when both devices are in a non-hazardous area.

Table of Contents

Introduction.....	7
Ordering Information.....	7
Key Features.....	9
Specifications	14
General.....	14
Strain Gauge Input	15
Relays.....	15
USB Connection.....	15
Isolated 4-20 mA Transmitter Output Option	16
RS-485 Serial Communications	16
Modbus® RTU Serial Communications.....	16
Digital Input (F4).....	16
MeterView Pro Software	16
Compliance Information.....	17
Electromagnetic Compatibility.....	17
Product Ratings and Approvals.....	17
EU Declaration of Conformity.....	18
Safety Information	18
Installation.....	18
Unpacking.....	18
Mounting.....	19
Installation Overview	21
MeterView Pro Software	21
Sensor Excitation Voltage Selection (EX+, EX-).....	22
Connections	22
Required & Factory Wired Connection.....	22
ProVu Electronics Module Layout	23
USB Connection	23
Power Connections.....	24
Signal Connections	25
Switch Configuration	25
Shunt Calibration	27
Relay Connections.....	27
Interlock Relay Feature	27
Switching Inductive Loads.....	28
RS-485 Connections.....	28
RS-485 Multi-Drop Connection	28
F4 Digital Input Connections.....	29
4-20 mA Output Connections.....	29
Analog Output Power Supply.....	29
Remote Programming.....	29
Setup and Programming.....	30
Overview	30
LED Status Indicators	30
Programming Buttons	31
SafeTouch Buttons	31
Display Functions & Messages.....	32
Main Menu.....	34
Setting Numeric Values	34
Setting Up the Meter (SEtUP).....	34
Setting the Input Signal (InPUt).....	35
Setting the Display Units (uNItS).....	35
Setting the Display Units or Custom Tags (uNItS)	36
Programming the Meter (PrOg).....	36
Calibrating the Meter with Strain Gauge/Load Cell (rEL).....	37
Setting the Display Parameter & Intensity (dSPLY)	39
Display Intensity (d-IntY).....	39
Setting the Relay Operation (rELRY).....	40
Setting the Relay Action.....	40
Programming Set and Reset Points	41
Setting Fail-Safe Operation.....	41
Programming Time Delay	41

- Relay and Alarm Operation Diagrams 41**
 - High Alarm Operation (Set > Reset) 41
 - Low Alarm Operation (Set < Reset) 42
 - High Alarm with Fail-Safe Operation (Set > Reset) 42
 - Low Alarm with Fail-Safe Operation (Set < Reset) 42
 - Time Delay Operation 42
 - Pump Alternation Control Operation 43
 - Relay Sampling Operation 43
- Relay Operation Details 44**
 - Overview 44
 - Relays Auto Initialization 44
 - Fail-Safe Operation 44
 - Front Panel LEDs 44
 - Latching and Non-Latching Relay Operation 44
 - Non-Latching Relay (Rule) 45
 - Non-Latching Relay with Manual Reset (Rule Reset) 45
 - Latching Relay (Loule) 45
 - Latching Relay with Clear (Loule Clear) 45
 - Acknowledging Relays 46
 - Pump Alternation Control Applications (Rule Error) 46
 - Setting Up the Interlock Relay (Force On) Feature 47
- Scaling the 4-20 mA Analog Output (Rule) 48**
- Reset Menu (rESEt) 48**
- Tare Menu (tArE) 48**
 - Tare Functionality (tArE) 48
- Manual Control Menu (MAnUal Control) 48**
- Setting Up the Password (PASS) 49**
 - Protecting or Locking the Meter 49
 - Making Changes to a Password Protected Meter 49
 - Disabling Password Protection 49
- Advanced Features Menu 50**
 - Advanced Features Menu & Display Messages 50
 - Noise Filter (FILTER) 51
 - Noise Filter Bypass (bYPASS) 51
 - Rounding Feature (round) 51
 - Modbus RTU Serial Communications (SErial) 51
 - Select Menu (SELEct) 52
 - Input Signal Conditioning (Function) 52
 - Auto-Zero (Rule 0) 52
 - Low-Value Cutoff (Loule off) 52
 - Analog Output Programming (Rout Program) 53
 - Programmable Function Keys User Menu (uSEr) 54
 - Internal Source Calibration (ISRL) 55
 - Error Message (Error) 55
- Meter Operation 56**
 - Button Operation 56**
 - SafeTouch Buttons 56**
- Function Keys Operation 57**
 - Digital Inputs Operation 57**
 - Maximum/Minimum Readings 57**
- Troubleshooting 58**
 - Diagnostics Menu (diagnostic) 58**
 - Testing the Display LEDs 58
 - Determining Software Version 58
 - Reset Meter to Factory Defaults 58**
 - Factory Defaults & User Settings 59
 - Troubleshooting Tips 60**

Table of Figures

Figure 1. Enclosure Dimensions – Front View.....	19
Figure 2. Enclosure Dimensions – Side Cross Section View	19
Figure 3. Sensor Excitation Voltage Selection.....	22
Figure 4. Integrated ProVu Required Connections	22
Figure 5. ProVu Electronics Module Layout	23
Figure 6. USB Connection	23
Figure 7. Power Connections	24
Figure 8. Strain Gauge Configuration Switch	25
Figure 9. Strain Gauge Powered by Internal Supply	26
Figure 10. Strain Gauge Powered by External Supply	26
Figure 11. mV Transducer Input Connections	26
Figure 12. Four-wire mV Transducer Connections.....	26
Figure 13. Shunt Resistor	27
Figure 14. Relay Connections	27
Figure 15. Interlock Connections	27
Figure 16. AC and DC Loads Protection.....	28
Figure 17. Low Voltage DC Loads Protection	28
Figure 18. RS-485 Diagnostic LEDs	28
Figure 19. Digital Input and Output Connections	29
Figure 20. F4 Digital Input Connections	29
Figure 21. 4-20 mA Output Connections	29
Figure 22. Analog Output Supply Powering Other Devices.....	29

Introduction

The ProtEX-MAX PD8-6100 is an explosion-proof digital strain gauge & load cell meter, ideal for weighing and force measurement applications. It features a dual-line display, with a main display 0.60" (15 mm) high, and a second display of 0.46" (12 mm) high superluminous LED digits, which can be read in any lighting condition, including direct sunlight. The meter is housed in a die-cast aluminum, field-mountable, NEMA 4X/IP68 rated enclosure for convenient indoor and outdoor installation.

The meter accepts mV input signals up to 300 mV. Three of the programming buttons can be custom-programmed for a specific operation. The mV input can be scaled to display the process in two different scales; for example, pounds on the main display and gallons on the second display.

A fully loaded ProtEX-MAX PD8-6100 meter comes with four SPDT relays, a 4 20 mA output, one 10 VDC sensor excitation, one 24 VDC power supply, five digital inputs and four digital outputs, and onboard RS-485 serial communications.

The four relays can be used for alarm indication or process control applications. The 4-20 mA isolated output, Modbus RTU serial communications, and digital I/O features make the ProtEX-MAX an excellent addition to any system.

SafeTouch Buttons

To make it possible to program and operate the ProtEX-MAX in a hazardous area, the programming buttons that are located behind the glass window can be operated without removing the cover by using the SafeTouch through-glass buttons. The operator puts their finger on the glass over the button and the button is actuated.



To learn more about SafeTouch buttons, see this video:

predig.com/videos/Safetouch_Buttons

Ordering Information

85-265 VAC Models

Model	Standard Features	Options Installed
PD8-6100-6H0	5 Digital Inputs, 4 Digital Outputs, RS-485 Communications	No options
PD8-6100-6H7		4 relays 4-20 mA output

12-24 VDC Models

Model	Standard Features	Options Installed
PD8-6100-7H0	5 Digital Inputs, 4 Digital Outputs, RS-485 Communications	No options
PD8-6100-7H7		4 relays 4-20 mA output

Accessories

Model	Description
PDA0001	3/4" M-NPT to F-M20 Reducer
PDA0002	3/4" M-NPT to 1/2" F-NPT Reducer
PDAPLUG75	3/4" Metal Conduit/Stopping Plug
PDA-SSTAG	Custom Stainless Steel Tag (see website for convenient ordering form)
PDA6848	2" U-Bolt Kit Zinc Plated Steel
PDA6848-SS	2" U-Bolt Kit Stainless Steel
PDA7485-I	RS-232 to RS-485 isolated converter
PDA8485-I	USB to RS-485 isolated converter

Helpful Videos

There are several videos that will help you get a better understanding of the features and functionality of the ProtEX-MAX products. Since the ProtEX-MAX meters have the same general features and functionality of the ProVu meters, appropriate videos for the ProVu meter are also included.

ProtEX-MAX Products Overview

Learn about the complete line of ProtEX-MAX products.



predig.com/videos/ProtEXMAX_Overview

MeterView Pro Programming Software

Learn how easy it is to program the ProVu (ProtEX-MAX) process meter using MeterView Pro software.



predig.com/videos/MVPro_SW

MeterView Pro Software Demonstration

Learn how easy it is to program Precision Digital's ProVu (ProtEX-MAX) process meter for a level application using MeterView Pro PC-based programming software.



predig.com/videos/MVPro_Demo

Connect to PC for Programming

Learn how to connect a ProVu (ProtEX-MAX) process meter to your PC and install free MeterView Pro programming software.



predig.com/videos/PC_Connect

Key Features

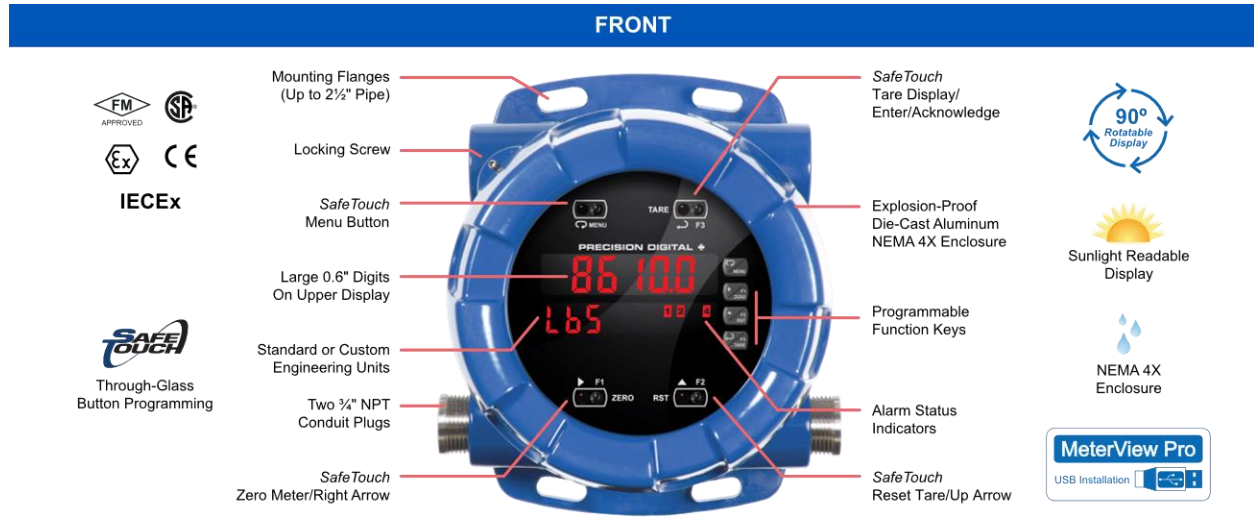

CONNECTIONS

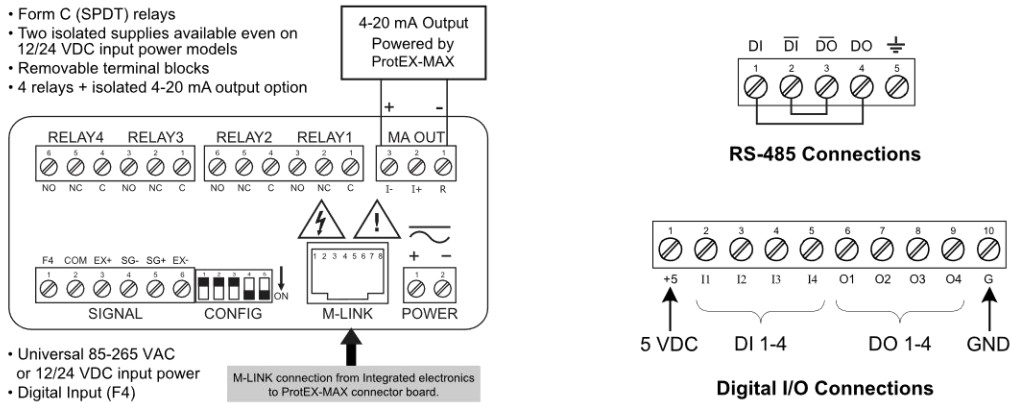

Connections for PD8-6100-6H7 & PD8-6100-7H7

The Only Explosion-Proof Strain Gauge and Load Cell Meter You Will Ever Need

The ProtEX-MAX PD8-6100 is a full-featured multipurpose, easy-to-use digital strain gauge & load cell meter ideal for weight and force measurement applications. The meter boasts specifications, features and functionality that make it the only hazardous area strain gauge and load cell meter you will ever need.

The PD8-6100 has all the same features as our PD6100 1/8 DIN meter, but it is not just a meter stuffed in an explosion-proof enclosure like many of our competitors offer. The PD8-6100 is approved as a complete product by FM and CSA and also carries IECEx approvals. Besides being suitable for hazardous areas, the number one feature that makes the PD8-6100 such a useful device is its built-in 5, 10 or 24 VDC power supply. This feature not only saves the cost of an external power supply, but also greatly simplifies wiring. In addition, there is a second 24 VDC @ 25 mA power supply provided with the 4-20 mA output option.

The first thing you notice about the PD8-6100 is its modern looking, rugged, die-cast aluminum housing with convenient mounting flanges. Housed inside this enclosure is a dual-line, 6-digit display with high-intensity LEDs that can be read in direct sunlight. The main display can be programmed to indicate PV, maximum (peak), minimum (valley), alternating max/min, one of four alarm set points, or Modbus input. The second display can also be configured to display engineering units, set points, user defined legends, or simply turned off.

The four relays can be used for alarm indication or process control such as pump alternation control. The 4-20 mA isolated output, Modbus RTU serial communications, and digital I/O options make the PD8-6100 an excellent addition to any system. Finally, all these features and capabilities can easily be programmed without removing the cover using SafeTouch buttons in a hazardous area or with free MeterView Pro PC-based software in a safe area.

Easy Programming Methods

The ProtEX-MAX can be programmed in a hazardous area with the through-glass SafeTouch buttons without removing the cover, in a safe area with the front panel push buttons with the cover removed, or in a safe area with free, PC-based MeterView Pro software. MeterView Pro is resident on the ProtEX-MAX and is accessed by a provided USB cable, so it is by far the easiest way to program the ProtEX-MAX. The ProtEX-MAX can be calibrated either by applying a known signal or scaled by entering a desired value with the front panel buttons or MeterView Pro software. Most customers will use the scaling method because it is simpler and does not require a calibrated signal source. Selecting the input to be current or voltage is done with the front panel buttons or MeterView Pro software. Once programming is completed it can be locked with a password.

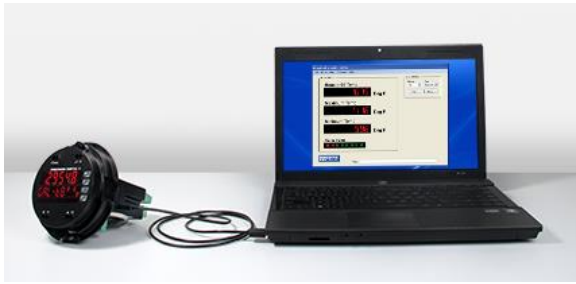

The ProtEX-MAX comes preloaded with free MeterView Pro programming software that connects and installs directly to your PC with a standard USB cable, also provided free with each instrument. This eliminates the need to insert CDs, install drivers, or download software from the internet. When you connect your ProtEX-MAX to your PC, MeterView Pro is downloaded to your PC, the software automatically selects the model you are programming, and you're ready to start programming immediately. Further simplifying the programming process, the ProtEX-MAX can be powered from the USB port, so no need to apply external power while programming your meter. In addition to programming, the software will also allow you to monitor, and datalog a ProtEX-MAX using your PC. You can also generate and save programming files for later use.

Feature Rich and Flexible

Zero the Meter

The zero function zeroes out the display. In the case where there has been drift in the strain gauge output over time, zero is used to eliminate this drift and provide a true zero reading. For example, if an empty scale were to display a value other than zero, the zero function would tell the meter to show zero regardless of the current input signal.

Capture Tare

The tare function also zeroes out the display. In the case of scale weight, tare is used to eliminate container weight and provide net weight readings. If the tare value is a known constant, such as a container weight, this may be programmed in manually. The captured tare may be reset manually with any function key or digital input.

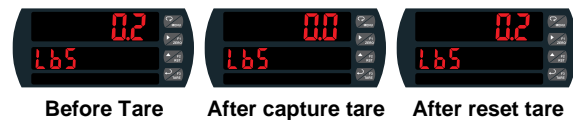

Automatic Unit Conversion

In addition to entering a custom unit or tag, pre-defined engineering units may be selected: lb, kg, ounce, gram, ton (short), tonne (metric ton). Automatic unit conversions are done when switching between pre-defined units, without the need for additional scaling. The meter converts the reading according to the unit selected. (e.g. 100.00 lb = 45.36 kg = 45359.2 g = 1600 oz).

Auto-Zero

The auto-zero feature corrects for drift that can occur over time that causes the input signal to slowly change. The meter will continue to read zero despite slow and small changes to the input signal around zero. The auto-zero sensitivity is set by the user as a percent of full scale.

Shunt Calibration Check

The PD8-6100 is equipped with a means of simulating strain in a strain gauge bridge circuit, via an included shunt resistor in the meter. This technique can be used as a means of verifying the meter setup and output behavior by simulating a physical input. With no load connected, the enabling of the shunt resistor will simulate a 70% full scale load in the case of a 350 Ω Strain Bridge.

Ratiometric Compensation

This feature compensates for changes in the strain gauge input signal that are due to variations in the internal or external excitation voltage. The compensation is effective for up to $\pm 5\%$ variation in the excitation power supply.

Advanced Display Features

Dual-Line Makes All the Difference

The main display can be programmed to indicate PV, maximum (peak), minimum (valley), alternating maximum/minimum, one of four alarm set points, or Modbus® input. The second display can be configured to display the input in a different scale, engineering units, set points, user defined messages, or simply turned off.

The ProtEX-MAX's dual-line display makes all the difference both when programming the instrument and when using it in the field. When programming the instrument, the dual-line display prompts for the needed information and also helps you keep track of where you are in the setup process. When using the instrument, the dual-line display provides more information such as displaying the input in two different scales like height and volume for a level application. We call this the Dual-Scale feature.

Programming Assistance

The ProtEX-MAX's dual-line display makes programming the instrument much easier because the second display prompts for the needed information and also helps you keep track of where you are in the setup process.



The ProtEX-MAX is prompting for the value for Input 2 and displaying the default value of 100 mV. The "0" is brighter than the rest of the digits indicating that it is the number that will be changed by the Up arrow.



The ProtEX-MAX is now prompting for what the user wants Display 2 to be; that is the value that corresponds to 100 mV. In this case Display 2 is currently set to 100.00.

Dual-Scale Display Feature

The ProtEX-MAX PD8-6100 has a rather unique, and very flexible dual-scale capability; a second scaled display can represent the measured input in a different form (i.e. gallons & height). This is of particular value in weight applications. Please see the examples shown below.

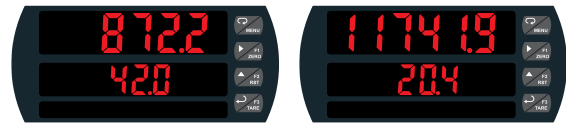

Volume & Height

Force & mV

Other Uses for Second Line

The second line can also be used indicate units, net and gross, a tag, or even a setpoint as the following pictures illustrate:

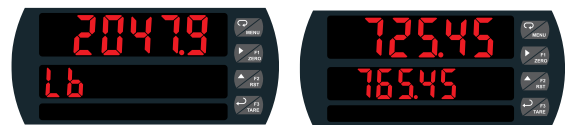

Weight & Units

Net & Gross



mV & Setpoint

Weight & Max (Peak)

Rounding for Steadier Display

The rounding feature is used to give the user a steadier display with fluctuating signals. It causes the display to round to the nearest value according to the rounding value selected (1, 2, 5, 10, 20, 50, or 100). For example, with a rounding value of 10, and an input of 12346, the display would indicate 12350.

Super-Bright Display

The ProtEX-MAX comes standard with a super-bright display, with LEDs that are visible even in direct sunlight. The display also has up to eight levels of adjustable intensity for optimum visibility in any lighting condition.

Physical Features

The ProtEX-MAX is designed for ease-of-use in safe and hazardous applications. The ProtEX-MAX is housed in a rugged NEMA 4X explosion-proof enclosure, can operate over a wide temperature range, includes removable screw terminal connectors, has worldwide approvals for use in hazardous areas, and features through-glass buttons for easy controller operation without the need to remove the cover. All of these features are backed by a 3-year warranty.

Super-Bright LED Display

The ProtEX-MAX features a dual-line 6-digit display with super-bright LEDs, our brightest ever. These allow the display to be read in any lighting condition, even in direct sunlight.



SafeTouch Through-Glass Buttons

The ProtEX-MAX is equipped with four sensors that operate as through-glass buttons so that it can be programmed and operated without removing the cover (and exposing the electronics) in a hazardous area. These buttons can be disabled for security by selecting the DISABLE setting on the NO-CONTACT BUTTONS switch located on the back of the electronics module, inside the enclosure.

Rugged, Heavy-Duty Enclosure

The ProtEX-MAX is housed in a rugged NEMA 4X, 7, & 9, IP68 die-cast aluminum enclosure, designed to withstand harsh environments in safe and hazardous areas over a wide temperature range.



Wide Viewing Angle

Customers can't always look at the display from straight on, so the window and display module have been optimized to provide a wide viewing angle of approximately $\pm 40^\circ$; nearly twice that of the competition.



Built-In Mounting Flanges

The ProtEX-MAX is equipped with four slotted flanges for wall mounting or NPS 1½" to 2½" or DN 40 to 65 mm pipe mounting.



Flexible Mounting & Wiring

The ProtEX-MAX features four ¾" NPT threaded conduit openings so that wiring can be routed to the most convenient conduit connection(s). Two ¾" NPT metal conduit plugs with 12 mm hex key fitting come installed.



Rotatable Display

The ProtEX-MAX rotatable display, along with four available conduit connections, provide for numerous installation options. The display can be rotated in 90° increments. Rotate it 90° for horizontal mounting.



Vertical Mounting

Horizontal Mounting

Perfect & Secure Fit Every Time

The internal cast rails ensure the ProtEX-MAX assembles together perfectly, quickly and securely; and everything lines up for optimal viewing every time. There are no standoffs to worry about breaking or getting out of alignment. Two spring-loaded, self-retaining, thumbscrews make the assembly a snap, while pressing the display as close to the glass as possible to improve wide angle viewing.

Stainless Steel Tags

PDA-SSTAG is a laser etched stainless steel tag accessory for any of your Precision Digital meters. The tag features custom text for equipment identification, instruction, or whatever else is needed in your facility. Each tag comes with a stainless steel wire and lead seal for easy mounting wherever you need it.



Removable Screw Terminals

Industrial applications require screw terminal connections for easy field wiring, and the ProtEX-MAX goes one step further in convenience by also making them removable.



Note: The above photograph is representative of the back of the PD8-6100 in every regard except for the signal input connector. See *PROVu Electronics Module Layout for PD8-6100-6H7 and PD8-6100-7H7* on page 23 for actual input signal connections.

USB Port MeterView Pro

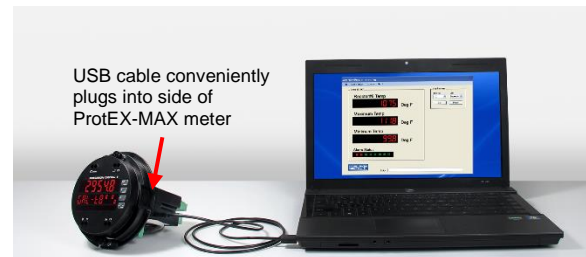

USB cable conveniently plugs into side of ProtEX-MAX meter

Hazardous Area Approvals

The ProtEX-MAX's approvals allow it to be used in hazardous areas around the world. These include: FM Approved as Explosion-Proof / Dust-Ignition-Proof / Flame-Proof, CSA Certified as Explosion-Proof / Dust-Ignition-Proof, and ATEX and IECEx Certified as Flame-Proof.

Wide Operating Temperature Range

The ProtEX-MAX can operate from -40 to 60°C (-40 to 140°F) meaning it can be installed in a wide variety of indoor and outdoor industrial applications. And over this range, the ProtEX-MAX will drift no more than 0.005% of calibrated span/°C max from 0 to 65°C ambient and 0.01% of calibrated span/°C max from -40 to 0°C ambient.

Specifications

Except where noted all specifications apply to operation at +25°C.

General

Display	Display Line 1: 0.60" (15 mm) high, red LEDs Display Line 2: 0.46" (12 mm) high, red LEDs 6 digits each (-99999 to 999999), with lead zero blanking
Display Intensity	Eight user selectable intensity levels. Default value is six.
Display Update Rate	5/second (200 ms)
LED Status Indicators	See <i>LED Status Indicators</i> on page 30 for details.
Overrange	Display flashes 999999
Underrange	Display flashes -99999
Display Assignment	Display Line 1: PV1, PV2, PCT, max & min, set points, PV & units, net & gross weight, Modbus input, millivolts. Display line 2: Same as Display Line 1; plus units, tag or turned off.
Units	Predefined: lb, kg, ounce, gram, ton, metric ton (tonne); and custom units.
Programming Methods	Four SafeTouch through-glass buttons when cover is installed. Mechanical buttons can be used with the cover removed. Free PC-based USB MeterView Pro programming software.
Noise Filter	Programmable from 2 to 199 (0 will disable filter)
Filter Bypass	Programmable from 0.1 to 99.9% of calibrated span
Recalibration	All ranges are calibrated at the factory. Recalibration is recommended at least every 12 months.
Max/Min Display	Max/min readings reached by the process are stored until reset by the user or until power to the meter is cycled.
Rounding	Select 1, 2, 5, 10, 20, 50, or 100 (e.g. rounding = 10, value = 123.45, display = 123.50).
Tare	There are three modes of tare operation: Capture Tare, Programmable Tare, and Off. See <i>Tare Functionality (t Rr E)</i> on page 48 for details.
Password	Three programmable passwords restrict modification of programmed settings. Pass 1: Allows use of function keys and digital inputs Pass 2: Allows use of function keys, digital inputs and editing set/reset points Pass 3: Restricts all programming, function keys, and digital inputs.
Non-Volatile Memory	All programmed settings are stored in non-volatile memory for a minimum of ten years if power is lost.

Power Options	85-265 VAC 50/60 Hz; 90-265 VDC, 20 W max; 12-24 VDC, 12-24 VAC, 15 W max. Powered over USB for configuration only.
Fuse	Required external fuse: UL Recognized, 5 A max, slow blow; up to 6 meters may share one 5 A fuse
Normal Mode Rejection	Greater than 60 dB at 50/60 Hz
Isolation	4 kV input-to-power line 500 V input-to-output (powered by external supply)
Overvoltage Category	Installation Overvoltage Category II: Local level with smaller transient overvoltages than Installation Overvoltage Category III.
Environmental	T6 Class operating temperature range Ta = -40 to 60°C T5 Class operating temperature range Ta = -40 to 65°C Storage temperature range: -40 to 85°C (-40 to 185°F) Relative humidity: 0 to 90% non-condensing
Max Power Dissipation	Maximum power dissipation limited to 15.1 W
Connections	Power, signal, relays, mA out: Removable screw terminal blocks accept 12 to 22 AWG wire. RS-485: Removable screw terminal block accepts 16 to 30 AWG wire. Digital I/O: Removable screw terminal blocks accept 16 to 30 AWG wire.
Enclosure	Explosion-proof die-cast aluminum with glass window, corrosion resistant epoxy coating, color: blue NEMA 4X, 7, & 9, IP68 Default conduit connections: Four ¾" NPT threaded conduit openings and two ¾" NPT metal conduit plugs with 12 mm hex key fitting installed. Additional conduit opening configurations may be available; verify quantity and sizes on specific device labeling during installation.
Mounting	Wall Mounting: Four (4) mounting holes provided for mounting meter to wall. See <i>Wall Mounting Instructions</i> on page 19 for additional details Pipe Mounting: Optional pipe mounting kit (PDA6848) allows for pipe mounting. Sold separately. See <i>Pipe Mounting Instructions</i> on page 20 for additional details.
Tightening Torque	Power, signal, relays, mA out terminals: 5 lb-in (0.56 Nm) Digital I/O and RS-485: 2.2 lb-in (0.25 Nm)
Overall Dimensions	6.42" x 7.97" x 8.47" (W x H x D) (163 mm x 202 mm x 215 mm)
Weight	16.0 lbs (7.26 kg)
Warranty	3 years parts & labor. See Warranty Information and Terms & Conditions on www.prediq.com for complete details.

Strain Gauge Input

Inputs	Field selectable: 0-15 mV, 0-30 mV, 0-150 mV, 0-300 mV, ±15 mV, ±25 mV, ±150 mV, ±250 mV, or Modbus PV (Slave)	
Isolated Sensor Power Supply	Terminals EX+ & EX-: 10 VDC or 5 VDC ± 10%, rated @ 25 mA max. Note: Do not use 24 VDC to power strain gauge bridge.	
Accuracy	±0.03% of calibrated span ±1 count	
Minimum Load Resistance	14 Ω @ 5 V 28 Ω @ 10 V	
Maximum Excitation Current	25 mA @ 5 V or 10 V	
Temperature Drift	0.002% of calibrated span/°C max from 0 to 65°C ambient, 0.005% of calibrated span/°C max from -30 to 0°C ambient	
Functions	Linear with multi-point linearization	
Multi-Point Linearization	2 to 32 points for PV or PV1 2 to 8 points for PV2 (Dual-scale feature)	
Low Cutoff	0.1 to 999,999 (0 disables cutoff function). Point below at which display always shows zero.	
Decimal Point	Up to five decimal places or none: dddddd, dddddd, dddd, dddd, dd, or dddddd	
Calibration Range	Input Range	Minimum Span Input 1 & Input 2
	15 mV	0.2 mV
	25 mV, 30 mV	0.4 mV
	150 mV	2.0 mV
	250 mV, 300 mV	4.0 mV
	An Error message will appear if the input 1 and input 2 signals are too close together.	
Input Impedance	Strain Gauge Bridge: Greater than 10 MΩ mV Source: 200 kΩ	

Relays

Rating	4 SPDT (Form C) internal and rated 3 A @ 30 VDC and 125/250 VAC resistive load; 1/14 HP (≈ 50 W) @ 125/250 VAC for inductive loads
Noise Suppression	Noise suppression is recommended for each relay contact switching inductive loads; see <i>Switching Inductive Loads</i> on page 27 for details.
Deadband	0-100% of span, user programmable
High or Low Alarm	User may program any alarm for high or low trip point. Unused alarm LEDs and relays may be disabled (turn off).
Relay Operation	<ul style="list-style-type: none"> • Automatic (non-latching) and/or manual reset • Latching (requires manual acknowledge) with or without clear • Pump alternation control (2 to 4 relays) • Sampling (based on time) • Off (disable unused relays and enable Interlock feature) • Manual on/off control mode
Relay Reset (Acknowledge)	User selectable via front panel button, F4 digital input, external contact closure on digital inputs, or through serial communications.
Time Delay	0 to 999.9 seconds, on & off relay time delays. Programmable and independent for each relay
Fail-Safe Operation	Programmable and independent for each relay. Note: Relay coil is energized in non-alarm condition. In case of power failure, relay will go to alarm state.
Auto Initialization	When power is applied to the meter, relays will reflect the state of the input to the meter.

USB Connection

Function	Programming only
Compatibility	USB 2.0 Standard, Compliant
Connector Type	Micro-B receptacle
Cable	USB A Male to Micro-B Cable
Driver	Microsoft® Windows® XP/Vista/7/8/10
Power	USB port provides power to the meter. DO NOT apply AC or DC power to the meter while the USB port is in use.

Isolated 4-20 mA Transmitter Output Option

Output Source	Process variable (PV), max, min, set points 1-4, Modbus input, or manual control mode		
Scaling Range	1.000 to 23.000 mA for any display range		
Calibration	Factory calibrated: 0.00 to 100.00 = 4-20 mA output		
Analog Output Programming	1.000 mA minimum and 23.000 mA maximum for all parameters: overrange, underrange, max, min, and break		
Accuracy	± 0.1% of span ± 0.004 mA		
Temperature Drift	0.4 µA/°C max from 0 to 65°C ambient, 0.8 µA/°C max from -40 to 0°C ambient Note: Analog output drift is separate from input drift.		
Isolated Transmitter Power Supply	Terminals I+ & R: 24 VDC ± 10% isolated from the input at >500 V. Used to power the 4-20 mA output Refer to <i>Figure 5. PROVu Electronics Module Layout</i> on page 23 and <i>Figure 21. 4-20 mA Output Connections</i> on page 29. All models rated @ 25 mA max.		
External Loop Power Supply	35 VDC maximum		
Output Loop Resistance	Power supply	Minimum	Maximum
	24 VDC	10 Ω	700 Ω
	35 VDC (external)	100 Ω	1200 Ω

RS-485 Serial Communications

Compatibility	EIA-485
Connectors	Removable screw terminal connector
Max Distance	3,937' (1,200 m) max
Status Indication	Separate LEDs for Power (METER LINK), Transmit (TX), and Receive (RX)

Modbus® RTU Serial Communications

Slave ID	1 – 247 (Meter address)
Baud Rate	300 – 19,200 bps
Transmit Time Delay	Programmable between 0 and 199 ms
Data	8 bit (1 start bit, 1 or 2 stop bits)
Parity	Even, Odd, or None with 1 or 2 stop bits
Byte-to-Byte Timeout	0.01 – 2.54 second
Turn Around Delay	Less than 2 ms (fixed)

Note: Refer to the *ProtEX-MAX Modbus Register Tables* located at www.predig.com for details.

Digital Input (F4)

Function	Operate tare function, remote operation of front-panel buttons, acknowledge/reset relays, reset max/min values. See <i>Function Keys & Digital I/O Available Settings</i> on page 54 for a complete list of capabilities.
Contacts	3.3 VDC on contact. Connect normally open contacts across F4 to COM
Logic Levels	Logic High: 3 to 5 VDC Logic Low: 0 to 1.25 VDC

MeterView Pro Software

Availability	Download directly from meter or from www.predig.com/download_software
System Requirements	Microsoft® Windows® XP/Vista/7/8/10
Communications	USB 2.0 (for programming only) (USB A Male to Micro-B Cable) RS-485 to USB converter (programming, monitoring, and data logging)
Configuration	Configure meters one at a time
Power	USB port provides power to the meter. DO NOT apply AC or DC power to the meter while the USB port is in use.

Compliance Information

Electromagnetic Compatibility

Emissions	EN 55022 Class A ITE emissions requirements
Radiated Emissions	Class A
AC Mains Conducted Emissions	Class A
Immunity	EN 61326-1 Measurement, control, and laboratory equipment EN 61000-6-2 EMC heavy industrial generic immunity standard
RFI - Amplitude Modulated	80 -1000 MHz 10 V/m 80% AM (1 kHz) 1.4 - 2.0 GHz 3 V/m 80% AM (1 kHz) 2.0 - 2.7 GHz 1 V/m 80% AM (1 kHz)
Electrical Fast Transients	±2kV AC mains, ±1kV other
Electrostatic Discharge	±4kV contact, ±8kV air
RFI - Conducted	10V, 0.15-80 MHz, 1kHz 80% AM
AC Surge	±2kV Common, ±1kV Differential
Surge	1KV (CM)
Power-Frequency Magnetic Field	30 A/m 70%V for 0.5 period
Voltage Dips	40%V for 5 & 50 periods 70%V for 25 periods
Voltage Interruptions	<5%V for 250 periods

Note: Testing was conducted on meters with cable shields grounded at the point of entry representing installations designed to optimize EMC performance.

Product Ratings and Approvals

FM	Enclosure: Type 4X; IP66 Class I, Division 1, Groups B, C, D Class II, Division 1, Groups E, F, G Class III, Division 1, T5/T6 Class I, Zone 1, AEx d, IIC Gb T5/T6 Zone 21, AEx tb IIIC T90°C; Ta = -40°C to +65°C T6 Ta = -40°C to +60°C; T5 Ta = -40°C to +65°C Certificate Number: 3047283
CSA	Class I, Division 1, Groups B, C, D Class II, Division 1, Groups E, F, G Class III, Division 1 Class I Zone 1 Ex d IIC Zone 21 Ex tb IIIC T90°C -40°C < Tamb. < +60°C; Temperature Code T6 -40°C < Tamb. < +65°C; Temperature Code T5 Enclosure Type 4X & IP68 Certificate Number: 2531731
ATEX 	II 2 G D Ex d IIC T* Gb Ex tb IIIC T90°C Db IP68 Ta = -40°C to +°C *T6 = -40°C to +60°C *T5 = -40°C to +65°C Certificate number: Sira 12ATEX1182
IECEx	Ex d IIC T* Gb Ex tb IIIC T90°C Db IP68 Ta = -40°C to +°C *T6 = -40°C to +60°C *T5 = -40°C to +65°C Certificate Number: IECEx SIR 12.0073

Special Conditions for Safe Use:

Use suitably certified and dimensioned cable entry device and/or plug. The equipment shall be installed such that the supply cable is protected from mechanical damage. The cable shall not be subjected to tension or torque. If the cable is to be terminated within an explosive atmosphere, then appropriate protection of the free end of the cable shall be provided. Cable must be suitable for 90°C.

Year of Construction

This information is contained within the serial number with the first four digits representing the year and month in the YYMM format.

For European Community: The ProtEX-MAX must be installed in accordance with the ATEX directive 94/9/EC, and the product certificate Sira 12ATEX1182.

EU Declaration of Conformity

EU Declaration of Conformity is available in the Documentation CD provided with the product under the EU DoC menu.

Safety Information

⚠ CAUTION

- Read complete instructions prior to installation and operation of the meter.

⚠ WARNINGS

- Risk of electric shock or personal injury.
- Hazardous voltages exist within enclosure. Installation and service should be performed only by trained service personnel.

Installation

Install in accordance with applicable local and national regulations (e.g. NEC).

For Installation in USA

The ProtEX-MAX must be installed in accordance with the National Electrical Code (NEC) NFPA 70.

For Installation in Canada

The ProtEX-MAX must be installed in accordance with the Canadian Electrical Code CSA 22.1. All power supplies below 36 V and input circuits must be derived from a CSA Approved Class 2 source.

For European Community

The ProtEX-MAX must be installed in accordance with the ATEX directive 94/9/EC and the product certificate Sira 12ATEX1182.

⚠ WARNINGS

- Disconnect from supply before opening enclosure.
- Keep cover tight while circuits are live.
- Conduit seals must be installed within 18" (450mm) of the enclosure or within 2" (50mm) for Zone installations.

Wiring connectors are accessed by opening the enclosure. To access electrical connectors, remove the 2 captive screws and then remove the electronics module. Connectors are on the rear of the electronics module.

Unpacking

Remove the meter from box. Inspect the packaging and contents for damage. Report damages, if any, to the carrier.

If any part is missing or the meter malfunctions, please contact your supplier or the factory for assistance.

Pre-Installed Conduit Plugs

The ProtEX-MAX is supplied with two pre-installed conduit plugs for installations that do not require the use of all four conduit entries. The conduit/stopping plugs include an internal hexagonal socket recess for removal. The conduit plugs and their factory installation are included in all hazardous area approvals of this product.

⚠ WARNING

- In hazardous areas, conduit and conduit/stopping plugs require the application of non-setting (solvent free) thread sealant. It is critical that all relevant hazardous area guidelines be followed for the installation or replacement of conduit or plugs.

Cover Jam Screw



The cover jam screw should be properly installed once the meter has been wired and tested in a safe environment. The cover jam screw is intended to prevent the removal of the meter cover in a hazardous environment without the use of tools. Using a M2 hex wrench, turn the screw clockwise until the screw contacts the meter. Turn the screw an additional 1/4 to 1/2 turn to secure the cover.

⚠ CAUTION

- Excess torque may damage the threads, screw head, and wrench.

Mounting

The ProtEX-MAX has four slotted mounting flanges that may be used for pipe mounting or wall mounting. Refer to *Figure 1* and *Figure 2* below.

WARNING

- Do not attempt to loosen or remove flange bolts while the meter is in service.

Mounting Dimensions

All units: inches (mm)

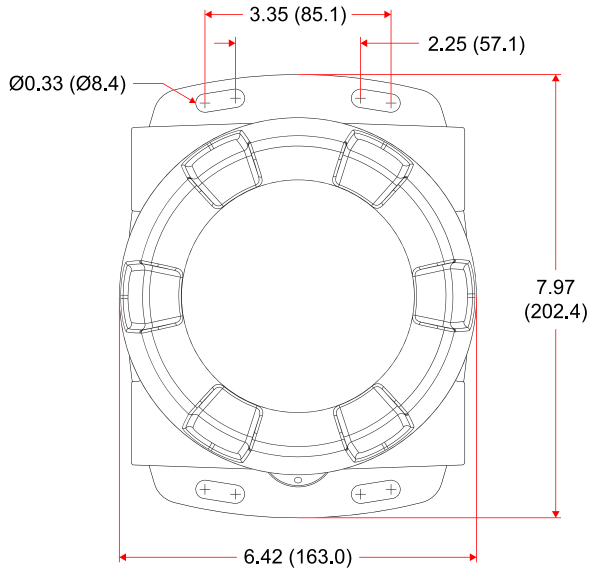

Figure 1. Enclosure Dimensions – Front View

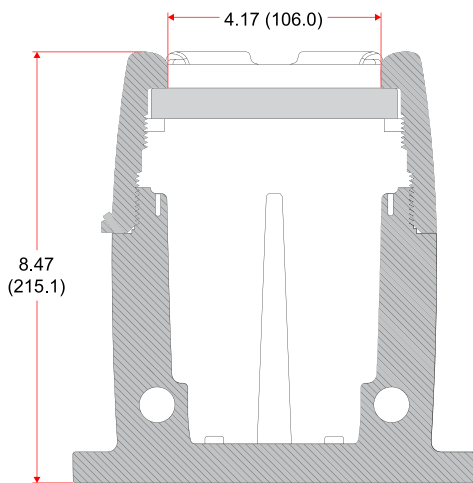

Figure 2. Enclosure Dimensions – Side Cross Section View

Wall Mounting Instructions

The meter can be mounted to any wall or flat surface using the four provided mounting holes located in the cast-in flanges. In addition, the internal electronic assembly can be rotated to allow the enclosure to be mounted in any position. To mount the meter to a wall, follow these instructions:

- Prepare a section of wall approximately 7" x 8.5" (178 mm x 216 mm) for meter mounting by marking with a pencil the mounting holes (shown in *Figure 1*) on the wall.
- Select the appropriate mounting screws for the mounting surface to be used. The mounting holes diameter is shown on *Figure 1*.

Note: Mounting screws are not included.

- Using a drill bit slightly smaller than the girth of the mounting screws, pre-drill holes at the mounting locations previously marked.
- Insert mounting screws into the four mounting holes and screw them into the pre-drilled holes.



Download free 3-D CAD files of these instruments to simplify your drawings!

predig.com/documentation-cad

Pipe Mounting Instructions



The meter can also be mounted to a pipe using an optional U-Bolt kit. This kit includes two U-bolts, the necessary hardware, and is available in zinc plated steel ([PDA6848](#)) and 316 stainless steel ([PDA6848-SS](#)).



To mount the meter using a U-Bolt kit, follow these instructions:

- Orient the groove on the back of the instrument with the pipe and secure it to the pipe with the two U-bolts and hardware provided.



Vertical Pipe Mounting

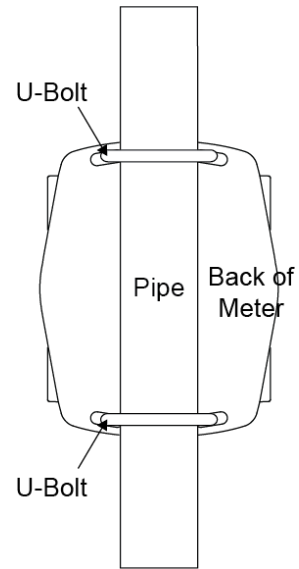

Horizontal Pipe Mounting

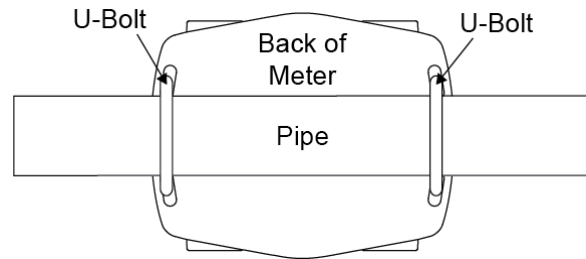

Installation Overview

We recommend the following sequence for getting the meter into service:

1. **DO NOT** apply AC or DC power to the meter.
2. Connect the meter to the PC with the USB cable provided. **DO NOT** use a different USB cable.
3. If MeterView Pro (MVPro) is already installed in your computer, then the program will launch automatically in most systems. If the program does not start automatically, double-click on the MVPro icon.
4. If MVPro is not installed, follow the instructions provided below.
5. Use MVPro to configure the meter for your application.
6. Disconnect the USB cable from the meter.
7. Apply power and signal and check operation of the meter.
8. Install the meter and put into service.
9. Make any programming adjustments using the programming buttons.

MeterView Pro Software

The easiest and quickest way to program your ProtEX-MAX meter is to use the FREE MeterView Pro programming software. This software is loaded into the meter and connects and installs directly to your PC with the USB cable provided. **DO NOT** use a different USB cable. We recommend that the first thing you do after taking the meter out of the box is connect the ProtEX-MAX to your PC with the provided USB cable. **DO NOT** apply AC or DC power to the meter while your PC is connected to the meter as it will disrupt the USB connection. It is not necessary to apply an input signal.

MeterView Pro programming software is intuitive, and most customers can get their meter programmed as they like without even looking in the manual.

Watch Meterview Pro Software Video at www.prediq.com/meterviewpro

MeterView Pro Installation

1. Connect one end of the provided USB cable to the meter and the other end to the computer. The computer will automatically install the driver software it needs to talk to the meter. Follow the on-screen instructions and allow sufficient time for the process to complete. This can take a few minutes. If the process is interrupted, then it could leave the system in an unstable condition.

⚠ WARNINGS

- Only one meter may be connected at a time. Attaching multiple meters will cause a conflict with the meter software.
- **DO NOT** apply AC or DC power to the meter when using the USB connection.
- When using the USB connection, the meter should only be connected to a computer when both devices are in a non-hazardous area.

2. Once the driver is installed, an AutoPlay dialog should appear for the drive "MAINSTAL." Click "Open folder to view files."

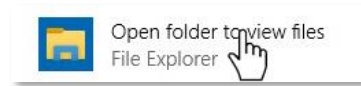

If the computer does not display an AutoPlay dialog for the drive "MAINSTAL," you should open My Computer and double-click on the drive labeled "MAINSTAL."

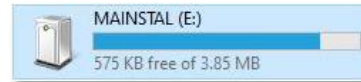

3. Double-click on the file named "MAStart." The program will open a few windows and install two programs on your computer. Simply follow the on-screen instructions until you see one of the dialogs below. If you receive a "User Account Control" warning, click "Yes."

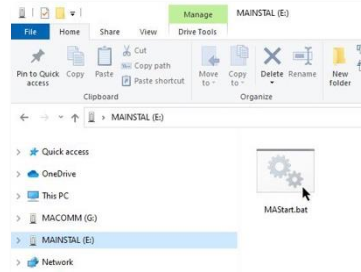

4. If there is an update available, click the "Update" button to install the new version. Otherwise, click "Configure" to begin programming your meter.

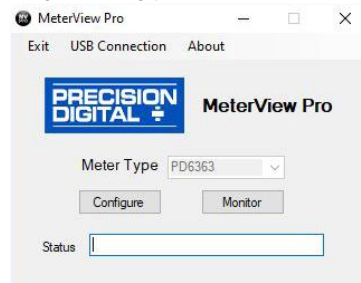

Note: If you decide to update your MeterView Pro software, once the installation has completed, you will be asked if you want to update the setup files located on the meter itself. This way, you will always have the most current version on the meter for future installs.

⚠ WARNING

- **DO NOT** unplug the meter while the new installation files are being written to it. The meter will display  during the process and you will receive an on-screen notification once the process is complete.
- Do not disconnect and reconnect the scanner rapidly. Allow at least 10 seconds from disconnection before reconnecting USB to the meter.

Sensor Excitation Voltage Selection (EX+, EX-)

All meters, including models equipped with the 12-24 VDC power option, are shipped from the factory configured to provide 10 VDC excitation for the sensor.

If the sensor requires 5 VDC excitation, the internal jumper J3 must be configured accordingly.

To access the voltage selection jumper:

1. Remove all the wiring connectors.
2. Unscrew the back cover.
3. Slide out the back cover by about 1½ inches.
4. Configure the J3 jumper, located behind the input signal connector, for the desired excitation voltage as shown.

CAUTION

- Do not use 24 V to power a strain gauge bridge. The 24 V jumper configuration should only be used for mV input applications from 4-wire sensors.

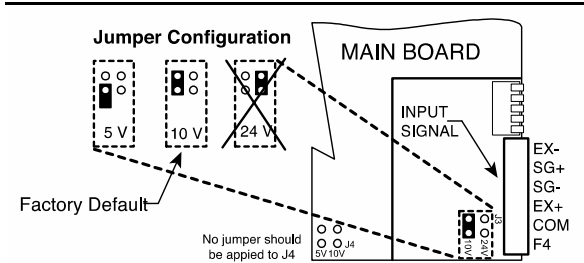

Figure 3. Sensor Excitation Voltage Selection

Connections

All connections are made to removable screw terminal connectors located at the rear of the meter.

CAUTION

- Use copper wire with 60°C or 60/75°C insulation for all line voltage connections. Observe all safety regulations. Electrical wiring should be performed in accordance with all applicable national, state, and local codes to prevent damage to the meter and ensure personnel safety.

WARNINGS

- Observe all safety regulations. Electrical wiring should be performed in accordance with all agency requirements and applicable national, state, and local codes to prevent damage to the meter and ensure personnel safety.
- Static electricity can damage sensitive components.
- Observe safe handling precautions for static-sensitive components.
- Use proper grounding procedures/codes.
- If the instrument is installed in a high voltage environment and a fault or installation error occurs, high voltage may be present on any lead or terminal.
- Follow all fusing and wiring precautions requirements for the instrument integrated to the PD8 Series model number being connected.

To access the connectors, remove the enclosure cover and unscrew the two captive screws that fasten the electronics module. Signal connections are made to de-pluggable connectors on the back of the electronics module.

Some connectors may be provided already connected. These connections are required for proper operation of the ProtEX-MAX and should not be removed unless instructed to by this manual.

Wires marked as being used for testing purposes should be removed.

Grounding connections are made to the two ground screws provided on the base – one internal and one external.

After all connections have been completed and verified, apply power to the unit.

Required & Factory Wired Connection

The ProtEX-MAX comes with a pre-wired connection. This connection is detailed below and must be maintained in order for the instrument to function properly.

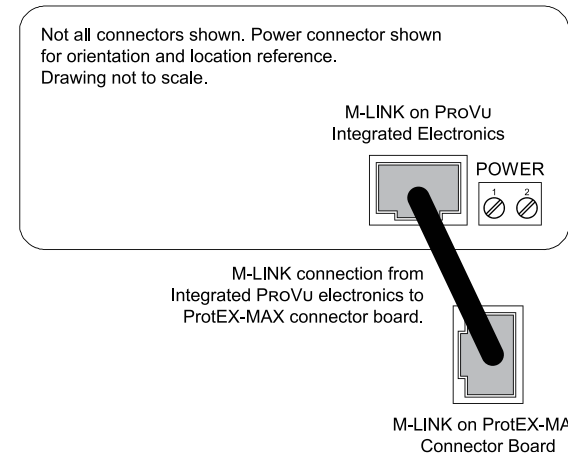

Figure 4. Integrated PROVu Required Connections

ProVu Electronics Module Layout for PD8-6100-6H7 and PD8-6100-7H7

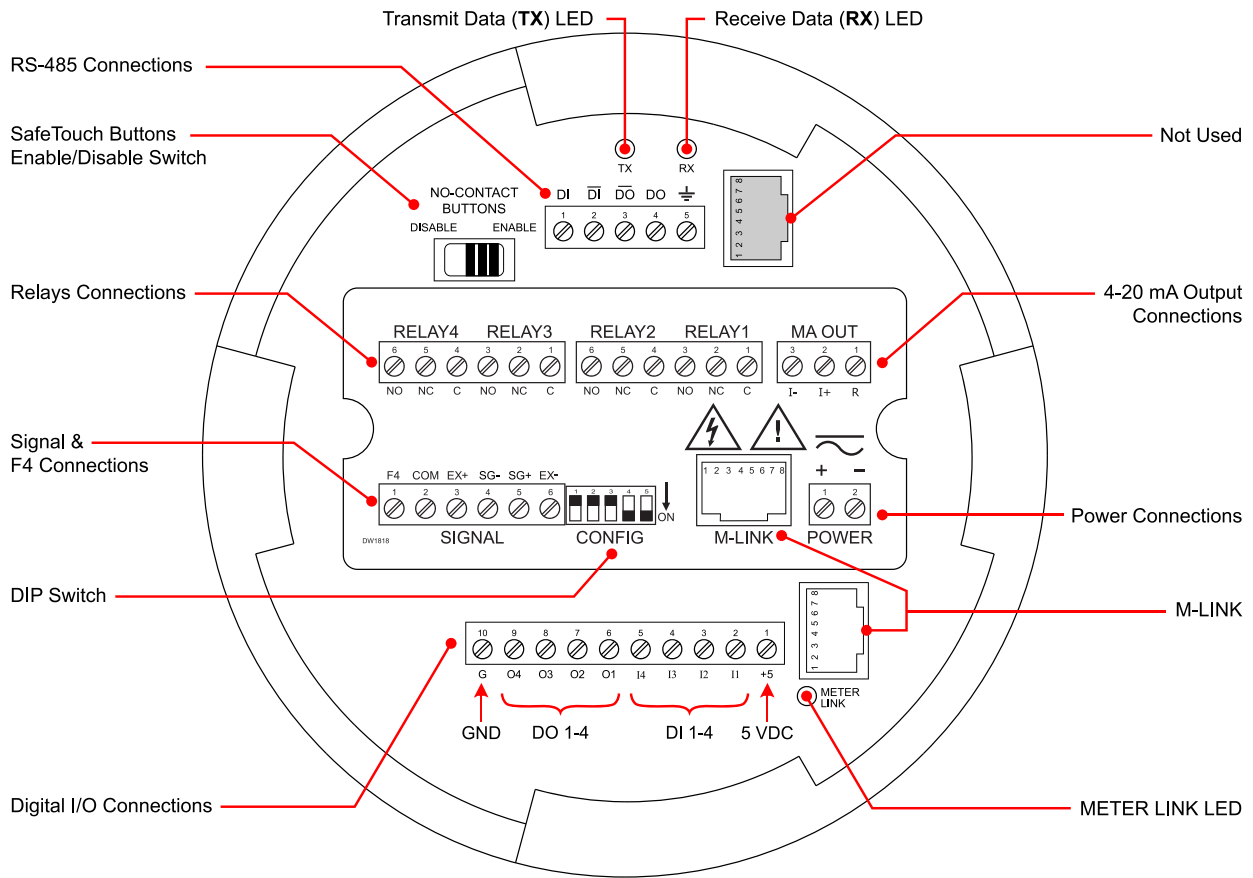

Figure 5. ProVu Electronics Module Layout

USB Connection

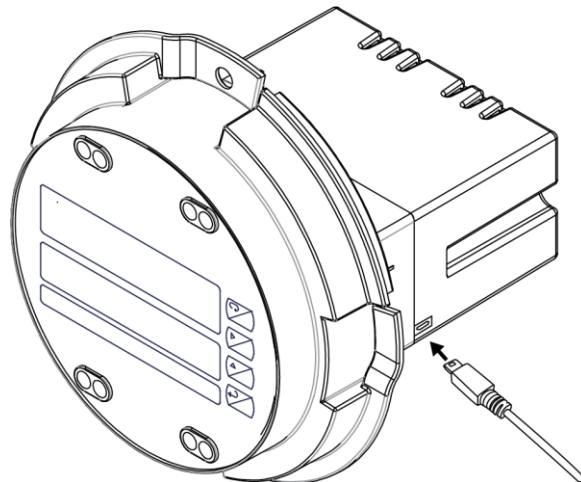

Figure 6. USB Connection

⚠ WARNINGS

- **DO NOT** disconnect the RJ45 M-LINK connector cable. Otherwise the instrument will not function properly.
- When using the USB connection, the meter should only be connected to a computer when both devices are in a non-hazardous area.

Power Connections

Power connections are made to a two-terminal connector labeled POWER. The meter will operate regardless of DC polarity connection. The + and - symbols are only a suggested wiring convention. There are separate models for low voltage and high voltage power. See *Ordering Information* on page 7 for details.

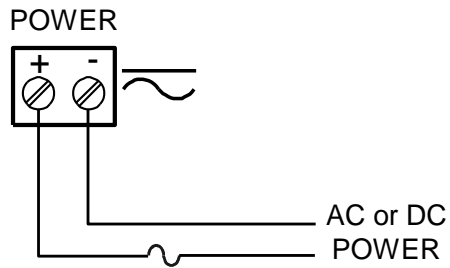

Required External Fuse:
5 A max, 250 V Slow Blow

Figure 7. Power Connections

Signal Connections

Signal connections are made to a six-terminal connector labeled SIGNAL. The EX+ and EX- terminals are used to sense the sensor excitation voltage for ratiometric operation when the sensor is powered externally (switch 1 is off).

Switch Configuration

Setup and programming is performed both through the programming buttons and switch settings shown below. The switch configuration must correspond to the *Setup and Programming* starting on page 30 (same range, type, etc.).

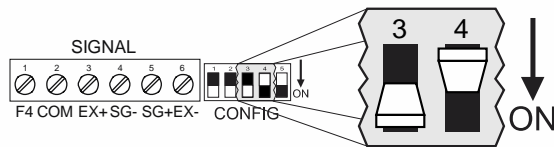

Figure 8. Strain Gauge Configuration Switch

Excitation (Switch 1)

The excitation switch designates whether the meter will use its internal power supply or an external power supply.

OFF	Excitation	<u>External</u> Excitation	When switch is turned OFF, an external power supply is used.
ON	Excitation	<u>Internal</u> Excitation	When switch is turned ON, the ProtEX-MAX's power supply is used.

Range (Switch 2)

The range switch adjusts the gain of the internal circuitry. Narrower ranges require more amplification.

OFF	Range	<u>Lower</u> internal gain	Turn this switch OFF for the following input ranges: 150, 300, ±150, or ±250 mV.
ON	Range	<u>Higher</u> internal gain	Turn this switch ON for the following input ranges: 15, 30, ±15, or ±25 mV.

Polarity (Switch 3)

The polarity switch selects whether the range is unipolar and starts at zero (i.e. 0 to 30 mV) or bipolar and starts at a negative value, or below zero (i.e. -15 to +15 mV).

OFF	Polarity	Range <u>starts</u> below zero (bipolar)	Turn this switch OFF for the following input ranges: ±15, ±25, ±150, or ±250 mV.
ON	Polarity	Range <u>starts</u> at zero (unipolar)	Turn this switch ON for the following input ranges: 15, 30, 150, or 300.

Source (Switch 4)

The source switch tells the ProtEX-MAX whether the input is a strain gauge bridge or it is a signal from a 2 or 4 wire transducer, or mV source (i.e. *Figure 11. mV Transducer Input Connections*, page 26)

OFF	Source	Source is strain gauge bridge	Turn this switch OFF if the source is a strain gauge bridge
ON	Source	Source is mV input transducer	Turn this switch ON if the connected source is a transducer*

*Ratio should be set to NO in Setup Input Menu

Shunt Resistor (Switch 5)

The PD8-6100 provides a means of simulating strain in a strain gauge bridge circuit via a 60.4KΩ shunt resistor included in the meter. This will simulate an approximate 70% full-scale load in the case of a 350Ω strain bridge.

OFF	Shunt	Shunt resistor is <u>disconnected</u> from the input bridge.	Turn this switch OFF to remove the shunt resistor
ON	Shunt	Shunt resistor is <u>connected</u> to the input bridge.	Turn switch ON when you want to simulate a strain load

Strain Gauge Connections

The following figures show examples of strain gauge connections.

There is a 5-position DIP switch (CONFIG) to set up the input ranges and sensor excitation.

Note: Refer to Switch Configuration on page 25 for proper configuration switch positioning.

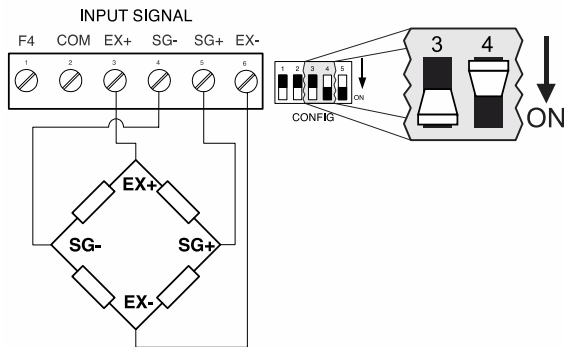

Figure 9. Strain Gauge Powered by Internal Supply

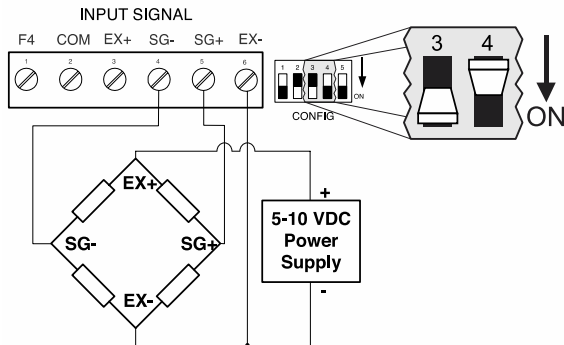

Figure 10. Strain Gauge Powered by External Supply

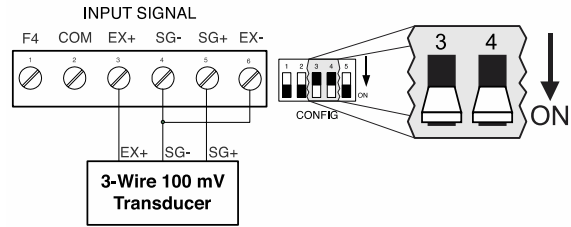

Figure 11. mV Transducer Input Connections

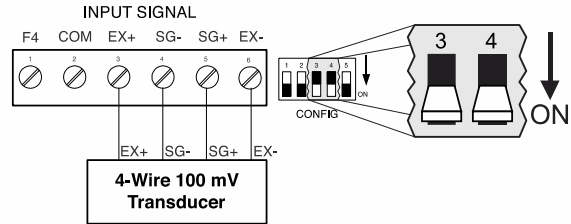

Figure 12. Four-wire mV Transducer Connections

Notes

- Two-wire mV signals: Connect positive to SG+ and negative to SG-
- Three-wire transducer: Connect EX- to SG-

Shunt Calibration

The PD8-6100 is equipped with a means of simulating strain in a strain gauge bridge circuit, via a shunt resistor included inside the meter. This technique is performed by enabling the “shunt resistor” switch (switch 5), which in turn shunts one leg of a connected strain bridge with a predetermined resistive load (60.4k). This technique can be used as a means of verifying instrumentation by simulating a physical input. With no load connected, the enabling of the shunt resistor (switch 5) will simulate approximately a 70% F.S. load in the case of a 350Ω Strain Bridge.

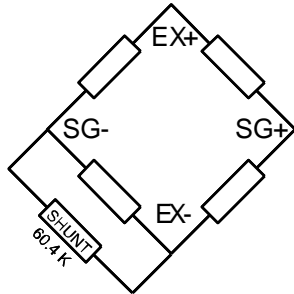

Figure 13. Shunt Resistor

Relay Connections

Relay connections are made to two six-terminal connectors labeled RELAY1 – RELAY4. Each relay’s C terminal is common only to the normally open (NO) and normally closed (NC) contacts of the corresponding relay. The relays’ C terminals should not be confused with the COM (common) terminal of the INPUT SIGNAL connector.

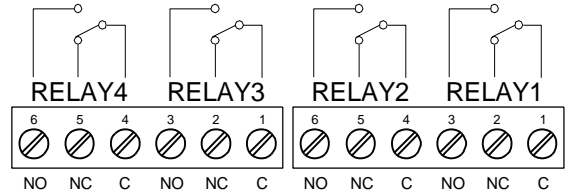

Figure 14. Relay Connections

Interlock Relay Feature

As the name implies, the interlock relay feature reassigns one, or more, alarm/control relays for use as interlock relay(s). Interlock contact(s) are wired to digital input(s) and activate the interlock relay. This feature is enabled by configuring the relay, and the corresponding digital input(s), see *Setting Up the Interlock Relay (Force On) Feature* on page 47.

In the example below, an Interlock Contact switch is connected to a digital input, which will be used to force on (energize) the Interlock Relay. The Interlock Relay and the Control Relay are connected in series with the load.

- When the Interlock Contact is closed (safe), the Interlock Relay energizes, allowing power to flow to the Control Relay; the corresponding front panel LED is on.
- When the Interlock Contact is open, the corresponding front panel LED flashes (locked out), the Interlock Relay is de-energized, preventing power from flowing to the Control Relay and the load.

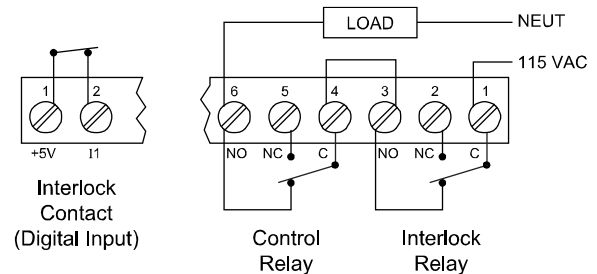

Figure 15. Interlock Connections

Switching Inductive Loads

The use of snubbers to suppress electrical noise is strongly recommended when switching inductive loads to prevent disrupting the microprocessor's operation. The snubbers also prolong the life of the relay contacts. Suppression can be obtained with resistor-capacitor (RC) networks assembled by the user or purchased as complete assemblies. Refer to the following circuits for RC network assembly and installation:

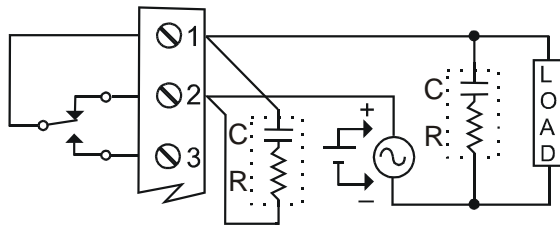

Figure 16. AC and DC Loads Protection

Choose R and C as follows:

R: 0.5 to 1 Ω for each volt across the contacts

C: 0.5 to 1 μF for each amp through closed contacts

Notes:

1. Use capacitors rated for 250 VAC.
2. RC networks may affect load release time of solenoid loads. Check to confirm proper operation.
3. Install the RC network at the meter's relay screw terminals. An RC network may also be installed across the load. Experiment for best results.

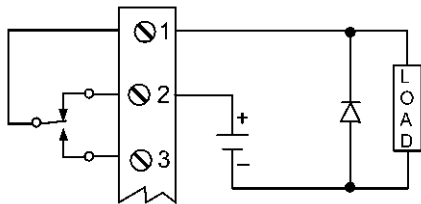

Use a diode with a reverse breakdown voltage two to three times the circuit voltage and forward current at least as large as the load current.

Figure 17. Low Voltage DC Loads Protection

RC Networks (Snubbers) Available from Precision Digital

RC networks are available from Precision Digital and should be applied to each relay contact switching an inductive load. Part number: [PDX6901](#).

Note: Relays are de-rated to 1/14th HP (50 watts) with an inductive load.

RS-485 Connections



The RS-485 connections are made to a five terminal connector used for Modbus RTU serial communications. The RS-485 terminals include Transmit Data (DO) and (/DO), Receive Data (DI) and (/DI), and Signal Ground. See *Modbus RTU Serial Communications (5E r iRL)* on page 51 for more information.

There are three diagnostic LEDs: Transmit Data (TX), Receive Data (RX) and METER LINK to show when the meter is transmitting and receiving data from other devices.



Figure 18. RS-485 Diagnostic LEDs

RS-485 Multi-Drop Connection

When using more than one meter in a multi-drop mode, each meter must be provided with its own unique address. The meter address (Slave ID) can be programmed between 1 and 247. The transmit delay can be set between 0 and 199 ms. The parity can be set to even, odd, or none with 1 or 2 stop bits.

To change the meter address:

1. Press and hold the Menu button for three seconds to access Advanced Features menu of the meter.
2. Press Up arrow until Serial (5E r iRL) menu is displayed and press Enter, Addr E5 is displayed.
3. Press Enter to change meter address using Right and Up arrow buttons. Press Enter to accept.
4. Press Menu button to exit and return to Run Mode.

Three-Wire Connection

In order to wire the five pins for use as a three-wire half-duplex RS-485 connection, it is necessary to create a jumper connection between DI to DO and /DI to /DO- as shown below.

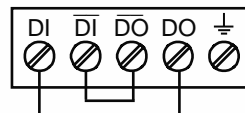

Digital I/O Connections



Digital inputs and outputs are provided in order to expand the functionality of the meter. Digital input connections are made via a push button or switch to the appropriate digital input terminal and the +5 VDC terminal. Digital output connections are made by wiring from the appropriate digital output terminal to the ground terminal.

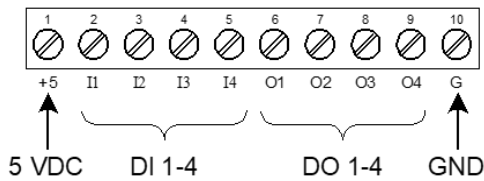

Figure 19. Digital Input and Output Connections

IMPORTANT

The onboard digital inputs (1-4) are configured at the factory to function identically to the front panel pushbuttons (Menu, F1, F2, & F3) in order to work with the SafeTouch buttons. Changing the programming of the digital inputs will affect the function of the SafeTouch buttons.

If you wish to change the behavior of the digital inputs, re-assign F1-F3 to the desired function, then change the corresponding digital input to match.

WARNING

- **DO NOT** disconnect the RJ45 M-LINK connector cable. Otherwise the instrument will not function properly.

F4 Digital Input Connections

A digital input, F4, is standard on the meter. This digital input should be connected with a normally open contact across F4 and COM, or with an active low signal applied to F4. It can be used to operate the tare function, for remote operation of front-panel buttons, to acknowledge/reset relays, or to reset max/min values. See *Function Keys & Digital I/O Available Settings* on page 54 for a complete list of capabilities.

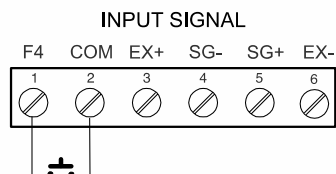

Figure 20. F4 Digital Input Connections

4-20 mA Output Connections

Connections for the 4-20 mA transmitter output are made to the connector terminals labeled mA OUT. The 4-20 mA output may be powered internally or from an external power supply.

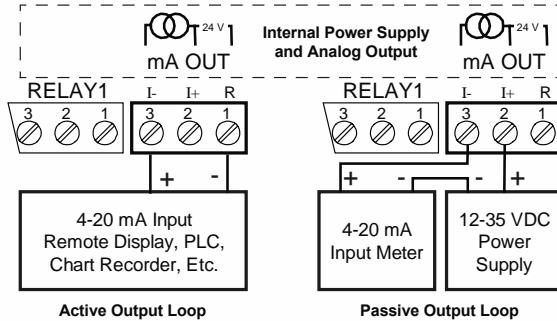

Figure 21. 4-20 mA Output Connections

Analog Output Power Supply

If the analog output is not using the 24 VDC supply to power the output loop, it can be used for other things. The I+ Terminal is the +24 V and the R terminal is the return.

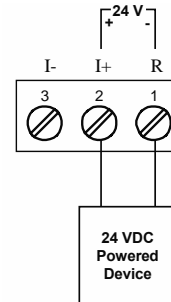

Figure 22. Analog Output Supply Powering Other Devices

Remote Programming

The meter can be operated via the programming buttons or a remote control station with required approvals to be located in a hazardous area using the digital inputs and outputs.

Setup and Programming

There is **no need to recalibrate** the meter when first received from the factory, if used to read millivolts.

The meter is **factory calibrated** prior to shipment for millivolts with calibration equipment that is certified to NIST standards.

If the meter is used with a strain gauge or load cell, it is recommended to perform a live calibration with the sensor connected.

Overview

There is a 5-position DIP switch on the back of the control module to set the meter input selection. See *Switch Configuration* on page 25 to setup the switch.

Setup and programming is done using MeterView Pro or through the programming buttons.









After power and input signal connections have been completed and verified, apply power to the meter.

LED Status Indicators

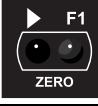

LED	State	Indication
1-4	Steady	Alarm condition based on set and reset points, independent of relay status in certain configurations. (Available on all meter configurations, including those without relays installed)
1-4	Flashing	Relay interlock switch open
1-4 & M	Flashing	Relay in manual control mode
T	Flashing	Meter in Tare mode
M	Flashing	Analog output in manual control mode
G	Steady	Gross value being displayed

Programming Buttons

Button	Description
 	Menu
 	Right Arrow/F1 ZERO THE DISPLAY
 	Up Arrow/F2 RESET TARE
 	Acknowledge (Enter)/F3 TARE

- Press the Menu button to enter or exit the Programming Mode at any time.
- Press the Right arrow button to move to the next digit during digit or decimal point programming.
- Press or hold the Up arrow button to scroll through the menus, decimal point, or to increment the value of a digit.
- Press the Enter button to access a menu or to accept a setting.
- Press and hold the Menu button for three seconds to access the advanced features of the meter.

SafeTouch Buttons

The ProtEX-MAX is equipped with four sensors that operate as through-glass buttons so that it can be programmed and operated without removing the cover (and exposing the electronics) in a hazardous area.

These buttons can be disabled for security by selecting DISABLE on the switch labeled NO-CONTACT BUTTONS located on the connector board.

To actuate a button, press one finger to the glass directly over the marked button area. Then retract finger more than three inches from the glass before pressing the next button. When the cover is removed, the four mechanical buttons located next to the sensors are used. The sensors are disabled when a mechanical button is pressed and will automatically be re-enabled after 60 seconds of inactivity.

The SafeTouch Buttons are designed to filter normal levels of ambient interference and to protect against false triggering, however, it is recommended that the SafeTouch Buttons be disabled (slide switch to DISABLE) if there is an infrared interference source in line-of-sight to the display.

The SafeTouch Buttons are configured by default to duplicate the function of the front panel mechanical pushbuttons associated with the integrated controller. The symbols by each SafeTouch button correspond to a mechanical button as shown in the above table.

SafeTouch Button Tips:

- To the extent possible, install the display facing away from sunlight, windows, reflective objects and any sources of infrared interference.
- Keep the glass window clean.
- Tighten the cover securely.
- Use a password to prevent tampering.



Display Functions & Messages

The meter displays various functions and messages during setup, programming, and operation. The following table shows the main menu functions and messages in the order they appear in the menu.

Display Functions & Messages		
Display	Parameter	Action/Setting Description
ሀይትሆፕ	Setup	Enter Setup menu
ከፖህት	Input	Enter Input selection menu
ፖሊፖላር	Polar	Enter unipolar or bipolar selection menu
ህኒ	Unipolar	Press Enter to select operation with positive signals only (e.g. 0-30 mV)
ቢ	Bipolar	Press Enter to select operation with positive & negative signals (e.g. ±15 mV)
ራንጅ	Range	Enter range selection menu
15 ማህ	15 mV	Set meter for 15 mV input (uni/bi)
25 ማህ	25 mV	Set meter for ±25 mV input (bi)
30 ማህ	30 mV	Set meter for 30 mV input (uni)
150 ማህ	150 mV	Set meter for 150 mV input (uni/bi)
250 ማህ	250 mV	Set meter for ±250 mV input (bi)
300 ማህ	300 mV	Set meter for 300 mV input (uni)
ራዲዮሜትሪክ	Ratiometric	Press Enter to select ratiometric operation to compensate for excitation changes.
ድ-ሀይትሆፕ	Dual-Scale	Press Enter to select dual-scale display (Select Yes or No)
ህኒ	Units	Select the display units/tags
ድሮራል ፖይንት	Decimal point	Set decimal point
ፖህ 1	PV1	PV1 decimal point (dual-scale)
ፖህ 2	PV2	PV2 decimal point (dual-scale)
ፕሮግራም	Program	Enter the Program menu
ሀይትሆፕ	Scale	Enter the Scale menu
ሀይትሆፕ 1	Scale 1	Enter the Scale menu for PV1
ሀይትሆፕ 2	Scale 2	Enter the Scale menu for PV2

Display Functions & Messages		
Display	Parameter	Action/Setting Description
ክሊቫ	Calibrate	Enter the Calibration menu
ከፖ 1	Input 1	Calibrate input 1 signal or program input 1 value
ድሀ 1	Display 1	Program display 1 value
ከፖ 2	Input 2	Calibrate input 2 signal or program input 2 value (up to 32 points)
ድሀ 2	Display 2	Program display 2 value (up to 32 points)
ፎላዩ	Error	Error, calibration not successful, check signal or programmed value
ድሀይትሆፕ	Display	Enter the Display menu
ሊን 1	Line 1	Press Enter to assign the upper display parameter (default: PV)
ሊን 2	Line 2	Press Enter to assign the lower display parameter (default: engineering units)
ድ-ከኒትሂ	Display intensity	Set display intensity level from 1 to 8
ራይሊ	Relay	Enter the Relay menu
ራይ 1	Relay 1	Relay 1 setup
ራይ 1 ሳይን	Action 1	Set relay 1 action
ራይ 1 ሳይን	Automatic	Set relay for automatic reset
ራይ 1 ሳይን	Auto-manual	Set relay for automatic & manual reset any time
ራይ 1 ሳይን	Latching	Set relay for latching operation
ራይ 1 ሳይን	Latching-cleared	Set relay for latching operation with manual reset only after alarm condition has cleared
ራይ 1 ሳይን	Alternate	Set relay for alternation control
ራይ 1 ሳይን	Sampling	Set relay for sampling operation
ቆፍ	Off	Disable relay and front panel status LED (Select Off to enable Interlock feature)
ሀይት 1	Set 1	Program set point 1
ራሀይት 1	Reset 1	Program reset point 1
ራይ 2	Relay 2	Relays 2-4 setup.
ፎላዩ ሳይን	Fail-safe	Enter Fail-safe menu
ፎላዩ 1	Fail-safe 1	Set relay 1 fail-safe operation
ኦን	On	Enable fail-safe operation

Display Functions & Messages		
Display	Parameter	Action/Setting Description
FLS 2	Fail-safe 2	Set relays 2-4 fail-safe operation
dELAY	Delay	Enter relay <i>Time Delay</i> menu
dLY 1	Delay 1	Enter relay 1 time delay setup
On 1	On 1	Set relay 1 On time delay
OFF 1	Off 1	Set relay 1 Off time delay
dLY 2	Delay 2	Enter relays 2-4 time delay setup
ROUT	Analog output	Enter the <i>Analog output</i> scaling menu
dS 1	Display 1	Program display 1 value
OUT 1	Output 1	Program output 1 value (e.g. 4.000 mA)
dS 2	Display 2	Program display 2 value
OUT 2	Output 2	Program output 2 value (e.g. 20.000 mA)
RESET	Reset	Press Enter to access the <i>Reset</i> menu
RES H	Reset high	Press Enter to reset max display
RES L	Reset low	Press Enter to reset min display
RES HL	Reset high & low	Press Enter to reset max & min displays
RES T	Reset tare	Press Enter to reset tare
TARE	Tare	Enter <i>Tare</i> menu
CAPTURE	Capture	Press Enter to set meter to capture tare using the Tare button
PROGRAM	Programmable	Press Enter to set meter to programmable tare and enter a value
OFF	Off	Press Enter to disable the tare function
CONTROL	Control	Enter <i>Manual Control</i> menu
AUTO	Automatic	Press Enter to set meter for automatic operation
MAN	Manual	Press Enter to manually control relays or analog output operation
PASS	Password	Enter the <i>Password</i> menu
PASS 1	Password 1	Set or enter Password 1
PASS 2	Password 2	Set or enter Password 2
PASS 3	Password 3	Set or enter Password 3

Display Functions & Messages		
Display	Parameter	Action/Setting Description
UNLOC	Unlocked	Program password to lock meter
LOCK	Locked	Enter password to unlock meter
999999 -999999	Flashing	Over/under range condition
FRULL	Flashing	Input exceeds range settings

Main Menu

The main menu consists of the most commonly used functions: *Setup*, *Reset*, *Tare*, *Control*, and *Password*.

- Press Menu button to enter Programming Mode then press the Up arrow button to scroll main menu.
- Press Menu, at any time, to exit and return to Run Mode. Changes made to settings prior to pressing Enter are not saved.
- Changes to the settings are saved to memory only after pressing Enter.
- The display moves to the next menu every time a setting is accepted by pressing Enter.

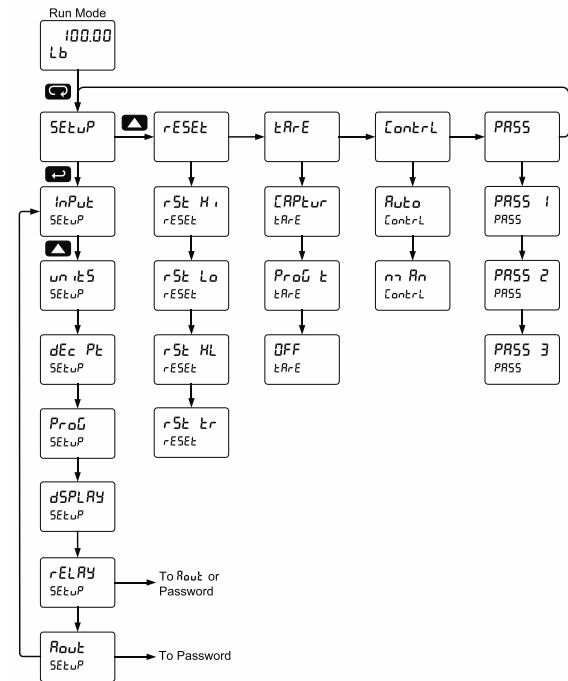

Setting Numeric Values

The numeric values are set using the Right and Up arrow buttons. Press Right arrow to select next digit and Up arrow to increment digit value.

The digit being changed is displayed brighter than the rest.

Press and hold up arrow to auto-increment the display value.

Press the Enter button, at any time, to accept a setting or Menu button to exit without saving changes.

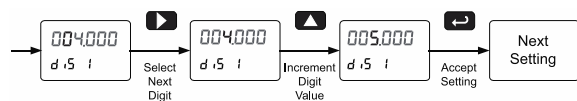

Setting Up the Meter (SEtUP)

The *Setup* menu is used to select:

1. Unipolar (e.g. 0-30 mV) or bipolar (e.g. ± 25 mV) polarity, input range, ratiometric operation, and dual-scale feature
2. Engineering units
3. Decimal point position
4. Program scaling or live calibration
5. Display parameter and intensity
6. Relay operation
7. 4-20 mA analog output scaling

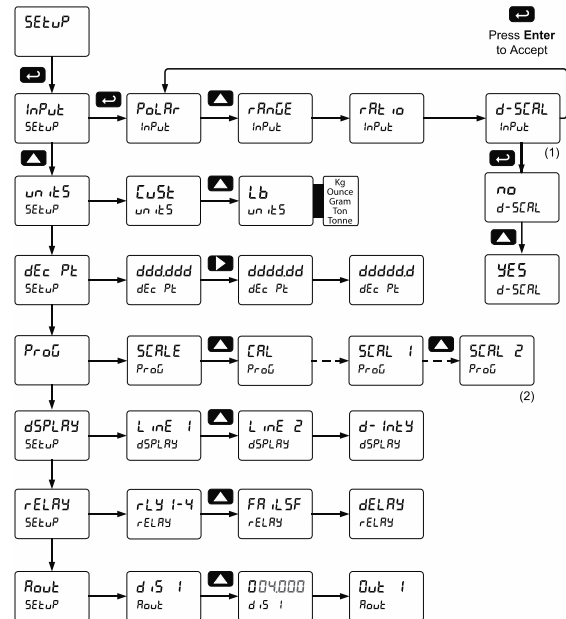

Notes:

1. Use the *d-SCAL* selection to activate the dual-scale level feature – PV1 & PV2. Set *d-SCAL* to *no* if both displays are to be used for anything other than PV1 & PV2.
2. *SCAL 1* & *SCAL 2* are displayed if *d-SCAL* is selected under the Setup Input menu. They correspond to the PV2 & PV2 scales.

Setting the Input Signal (InPut)

Enter the *Input* menu to set up the input polarity, range, ratiometric operation, and dual-scale feature. The meter is capable of accepting any signal from -250 to 250 mV in bipolar mode or up to 300 mV in unipolar mode.

After selecting "Yes" or "No" for *ratio*, *d-SCALE* is displayed. Selecting "Yes" enables the dual-scale feature, allowing scaling of the same input in two different scales (for PV1 & PV2) or displaying the percentage of PV1.

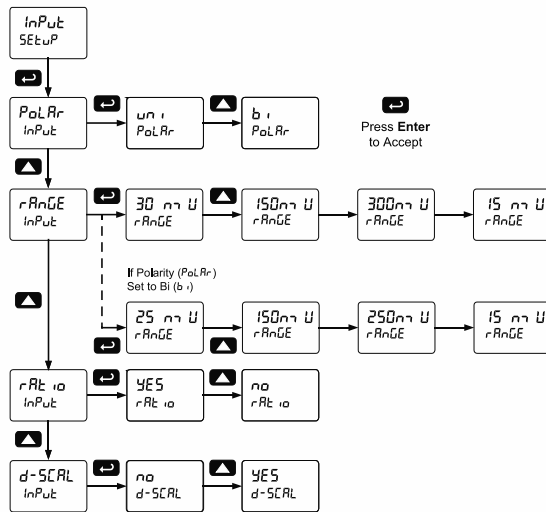

Input Polarity Selection (PolARr)

Select unipolar operation for inputs in ranges from 0 to 300 mV and select bipolar operation for inputs in ranges from -250 mV to +250 mV. This setting determines the selectable ranges for the millivolt input.

Note: Refer to *Switch Configuration* on page 25 for proper configuration switch positioning.

Range Selection (rAnGE)

This menu is used to select the input range. The selections listed are determined by the *Polarity* setting.

Unipolar mode: 0-15 mV, 0-30 mV, 0-150 mV, 0-300 mV

Bipolar mode: ±15 mV, ±25 mV, ±150 mV, ±250 mV

Note: Refer to *Switch Configuration* on page 25 for proper configuration switch positioning.

Ratiometric Operation (rAt io)

Ratiometric operation corrects the measured strain gauge signal for up to ±5% variation of either the internal or external excitation power supply. In order to use the ratiometric operation, the ratiometric operation menu must be set to yes (YES).

Dual-Scale (d-SCALE)

The mV input can be displayed in two different scales, by enabling the dual-scale feature in the *Setup-Input* menu. See *Dual-Scale (d-SCALE)* on page 35.

To enable the dual-scale feature you must select *d-SCALE* in the Input selection menu.

Setting the Display Units (un itS)

Enter the pre-defined engineering unit or custom unit. The pre-defined units have automatic conversion factors. This unit will be displayed if *d un itS* is selected as the lower display parameter. See *Setting the Display Parameter & Intensity (dSPLRy)* flow chart on page 39 to access the display menu to show the unit on the lower display.

The custom unit may also be used to enter a display tag.

Pre-defined engineering units: lb, kg, ounce, gram, ton (short), tonne (metric ton). The meter converts the reading according to the unit selected (e.g. 100.00 lb = 45.36 kg = 45359.2 g = 1600 oz).

Unit Conversions: After scaling values in the *Scale* menu have been entered during setup, automatic unit conversions are done when switching from any standard unit to any other standard unit during future changes of the *Units* menu.

Once a standard unit has been selected in the units menu, the user must then set their scaling values for that unit (under the setup menu) in order for that unit's conversion factor to take effect. Otherwise, the meter will allow the user to freely switch between standard unit selections, without applying a conversion factor.

Note that if the dual-scale feature is selected in the *Setup* menu, both PV1 and PV2 will be converted from the original standard unit to the new standard unit. A scaled PV not scaled for the selected units must be reprogrammed. *Example:* If PV 1 is scaled for pounds, and PV 2 scaled for gallons; if the *un itS* selection is changed from *Lb* to *OUNCE*, PV 2 will need to re-scaled manually back to gallons.

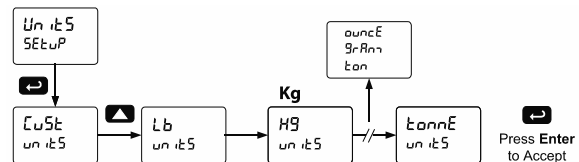

Note: PV1 and PV2 may use different standard units as starting points, however the user must select the unit and complete scaling for both PV1 and PV2 individually. For example, set PV1 equal to "Lbs" and complete the scaling for PV1 only. PV1 is now reading in Lbs. Then, change the units for PV2 to be "Kg" and complete the scaling for PV2.

Setting the Display Units or Custom Tags (Unit 5)

Enter the display unit or custom tag that will be displayed if units are selected in the Unit 5 menu, or *Unit* is selected as the lower display parameter. See *Setting the Display Parameter & Intensity (Display)* flow chart on page 39 to access the display menu to show the unit or tag on the lower display. The engineering units or custom legends can be set using the following 7-segment character set:

Display	Character	Display	Character
0	0	K	K
1	1	L	L
2	2	m	m
3	3	n	n
4	4	O	O
5	5	o	o
6	6	P	P
7	7	q	q
8	8	r	r
9	9	S	S
A	A	t	t
b	b	u	u
C	C	V	V
c	c	w	w
d	d	X	X
E	E	Y	Y
F	F	Z	Z
G	G	-	-
g	g	/	/
H	H	[[
h	h]]
i	i	=	=
J	J	Degree(<)	Degree(<)
		Space	Space

Notes:

1. Degree symbol represented by (<) if programming with MeterView Pro.
2. The letters "m" and "w" use two 7-segment LEDs each; when selected the characters to the right are shifted one position.
3. Press and hold up arrow to auto-scroll the characters in the display.

Setting the Decimal Point (dEc Pt)

The decimal point may be set with up to five decimal places or with no decimal point at all.

Pressing the Right arrow moves the decimal point one place to the right until no decimal point is displayed, and then it moves to the leftmost position.

Pressing the Up arrow moves the decimal point to the left. If the dual-scale feature is selected, the decimal point selections for PV1 & PV2 are enabled.

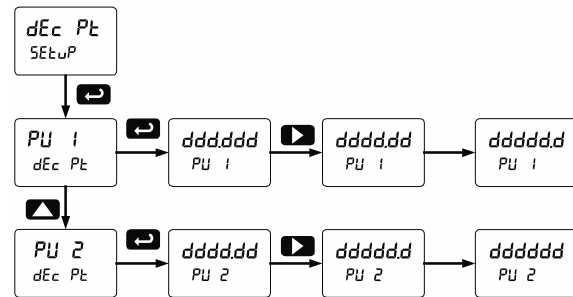

Programming the Meter (Prog)

The meter may either be scaled (SCALE) without applying an input or calibrated (CAL) by applying an input. The meter comes factory calibrated to NIST standards to read in millivolts, so for initial setup, it is recommended to use the (SCALE) function.

For strain gauge and load cell applications it is **recommended to calibrate** the meter using the sensor as the input and with ratiometric operation enabled to compensate for small variation in the excitation voltage.

The PD8-6100 is a single input meter with dual-scale capability. If the dual-scale feature is selected in the Setup menu, the *Scale 1* and *Scale 2* menus are enabled for PV1 & PV2 respectively.

The process inputs may be calibrated or scaled to any display value within the range of the meter.

Program Menu for Single Scale Process

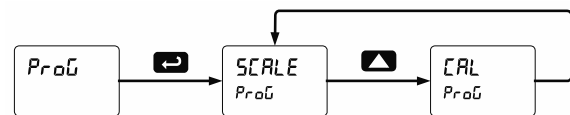

Program Menu for Dual-Scale Applications

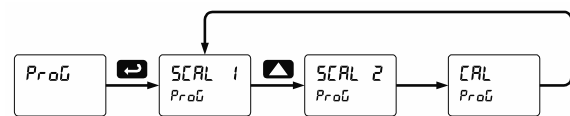

Additional parameters, not needed for most applications, are programmed in the *Advanced Features* menu. See *Advanced Features Menu* on page 50.

Calibrating the Meter with Strain Gauge/Load Cell (CRL)

To scale the meter without a signal source, refer to *Scaling the Meter (SCALE)* on page 37.

The meter can be calibrated to display the process variable in engineering units by applying the appropriate input signal and following the calibration procedure.

The use of a calibrated signal source is strongly recommended to calibrate the meter.

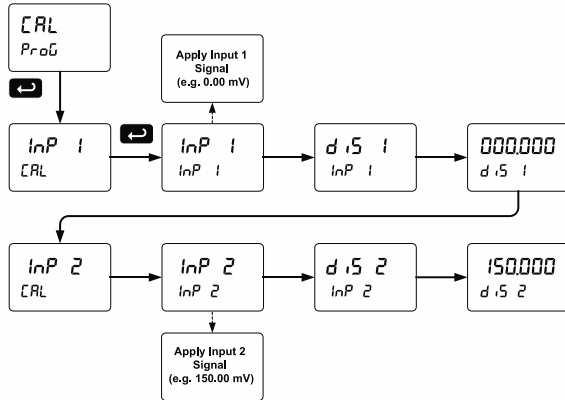

Note: Inputs for the above example are:
 Input 1: 0.00 mV; Display 1: 0.000 mV
 Input 2: 150.00 mV; Display 2: 150.000 mV

Warm up the meter for at least 15 minutes before performing calibration to ensure specified accuracy.

Multi-Point Calibration & Scaling

The meter is set up at the factory for 2-point linear calibration. The number of points for multi-point calibration/scaling is set up in the *Advanced Features* menu. Up to 32 linearization points may be selected for PV1 and up to 8 linearization points may be selected for PV2. See *Multi-Point Linearization (LINEAR)* on page 52 for details.

Scaling the Meter (SCALE)

The strain gauge input (e.g. 0-100 mV) can be scaled to display the process variable in engineering units.

A signal source is not needed to scale the meter; simply program the inputs and corresponding display values.

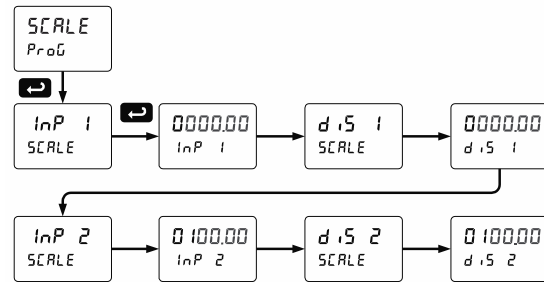

For instructions on how to program numeric values see *Setting Numeric Values* on page 34.

Dual-Scale Application

The mV input can be displayed in two different scales, by enabling the dual-scale feature in the *Setup Input* menu. See *Dual-Scale (d-SCALE)* on page 35.

To enable the dual-scale feature you must select it in the Input selection menu. See *Setting the Input Signal (input)* on page 35 for details.

Scaling the Input for PV1 (SCALE 1)

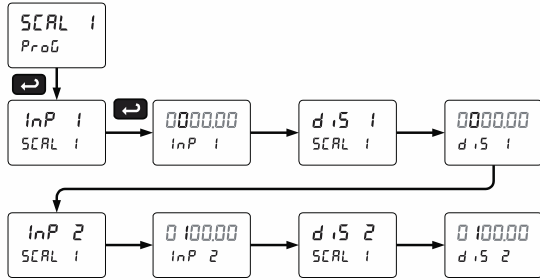

Scaling the Input for PV2 (SCALE 2)

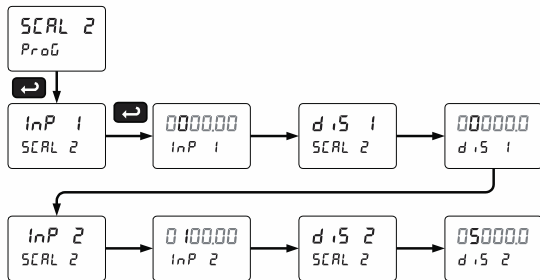

Error Message (Error)

An error message indicates that the calibration or scaling process was not successful.

After the error message is displayed, the meter reverts to input 2 during calibration or scaling and to input 1 during internal calibration, allowing the appropriate input signal to be applied or programmed.

The error message might be caused by any of the following conditions:

1. Input signal is not connected to the proper terminals, or it is connected backwards.
2. Wrong signal selection in *Setup* menu.
3. Minimum input span requirements not maintained.
4. Input 1 signal inadvertently applied to calibrate input 2.

Minimum Input Span

The minimum input span is the minimum difference between input 1 and input 2 signals required to complete the calibration or scaling of the meter.

Input Range	Input 1 & Input 2 Span
15 mV	0.2 mV
25 mV, 30 mV	0.4 mV
150 mV	2.0 mV
250 mV, 300 mV	4.0 mV

Setting the Display Parameter & Intensity (dSPLeRY)

Display line 1 (L nE 1) can be programmed to display:

1. Process value 1 (PV1)
2. Process value 2 (PV2)*
3. Percent of PV1 (Pct)*
4. Relay set points
5. Toggle process value & units
6. Max & min values
7. Gross value
8. Toggle net & gross values
9. Input millivolts
10. Modbus input

Display line 2 (L nE 2) can be programmed to display:

1. Engineering units or custom legends
2. Process value 1 (PV1)
3. Process value 2 (PV2)*
4. Percent of PV1 (Pct)*
5. Relay set points
6. Toggle process value & units
7. Max & min values
8. Gross value
9. Toggle net & gross values
10. Input millivolts
11. Modbus input
12. Off (no display)

*These menu items will only appear if Dual-Scale feature is turned on.

After setting up the input and display, press the Menu button to exit programming and skip the rest of the setup menu. Press the Menu button again and the Up arrow to reach the Program menu and complete the scaling or calibration of the meter.

Display Parameter Menu

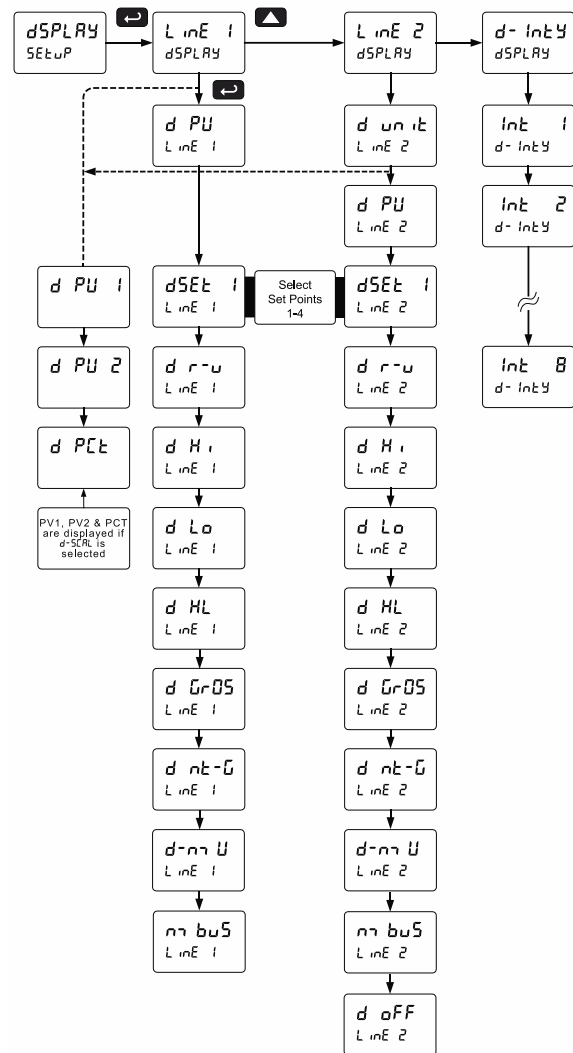

Display Intensity (d- nEtY)

The meter has eight display intensity levels to give the best performance under various lighting conditions. Select intensity 8 for outdoor applications. The default intensity is 6.

The PD8-6100 can be programmed so that the main display toggles between the reading and units and the second display displays a tag. For instance, the main display toggles between 9500 and Lbs and the second display reads Tank 1.



Dual-Scale Display Feature

The dual-scale feature is of particular value in weighing applications where a second scaled display can represent the measured input in a different form (i.e. pounds & height). Both displays are independently scaled and are based on the millivolt input signal.

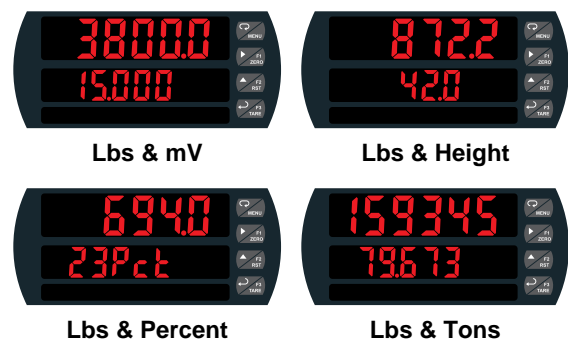

Setting the Relay Operation (rELRY)

This menu is used to set up the operation of the relays.

CAUTION

- During setup, the relays do not follow the input and they will remain in the state found prior to entering the Relay menu.

1. Relay action
 - a. Automatic reset only (non-latching)
 - b. Automatic + manual reset at any time (non-latching)
 - c. Latching (manual reset only)
 - d. Latching with Clear (manual reset only after alarm condition has cleared)
 - e. Pump alternation control (automatic reset only)
 - f. Sampling (the relay is activated for a user-specified time)
 - g. Off (relay state controlled by Interlock feature)
2. Set point
3. Reset point
4. Fail-safe operation
 - a. On (enabled)
 - b. Off (disabled)
5. Time delay
 - a. On delay (0-999.9 seconds)
 - b. Off delay (0-999.9 seconds)

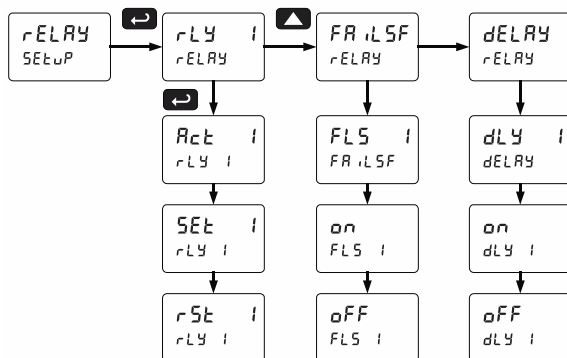

Note: The setup of relays 2-4 follows the same pattern shown here for relay 1.

Setting the Relay Action

Operation of the relays is programmed in the *Action* menu. The relays may be set up for any of the following modes of operation:

1. Automatic reset (non-latching)
2. Automatic + manual reset at any time (non-latching)
3. Latching (manual reset only, at any time)
4. Latching with Clear (manual reset only after alarm condition has cleared)
5. Pump alternation control (automatic reset only)
6. Sampling (the relay is activated for a user-specified time)
7. Off (relay state controlled by Interlock feature)

The following graphic shows relay 1 action setup; relay 2-4 are set up in a similar fashion.

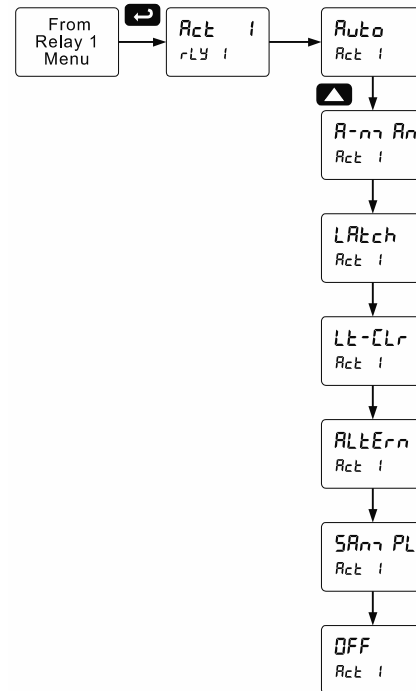

Programming Set and Reset Points

High alarm indication: program set point above reset point.

Low alarm indication: program set point below reset point.

The deadband is determined by the difference between set and reset points. Minimum deadband is one display count. If the set and reset points are programmed with the same value, the relay will reset one count below the set point.

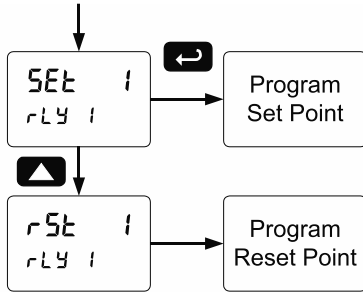

Note: Changes are not saved until the reset point has been accepted.

Setting Fail-Safe Operation

In fail-safe mode of operation, the relay coil is energized when the process variable is within safe limits and the relay coil is de-energized when the alarm condition exists. The fail-safe operation is set independently for each relay. Select **on** to enable or select **off** to disable fail-safe operation.

Programming Time Delay

The *On* and *Off* time delays may be programmed for each relay between 0 and 999.9 seconds. The relays will transfer only after the condition has been maintained for the corresponding time delay.

The *On* time delay is associated with the set point.

The *Off* time delay is associated with the reset point.

Relay and Alarm Operation Diagrams

The following graphs illustrate the operation of the relays, status LEDs, and ACK button.

High Alarm Operation (Set > Reset)

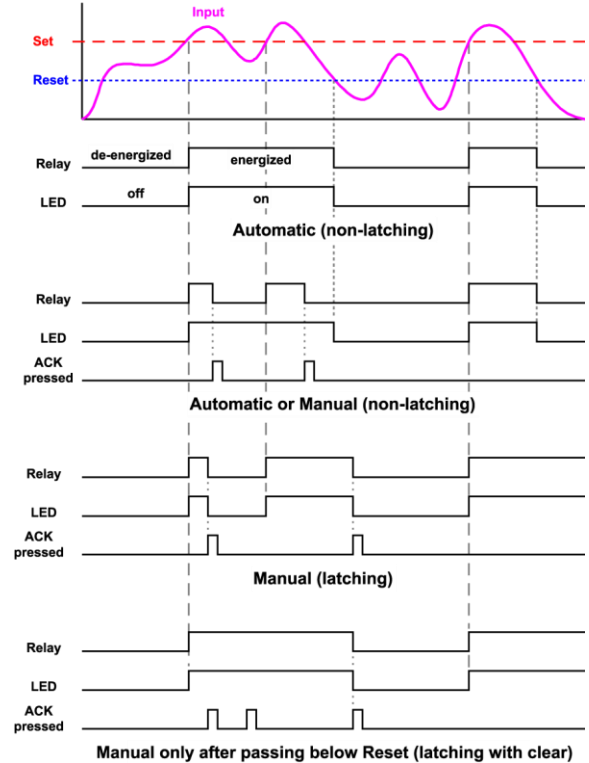

For Manual reset mode, ACK can be pressed anytime to turn "off" relay. To detect a new alarm condition, the signal must go below the set point, and then go above it.

Low Alarm Operation (Set < Reset)

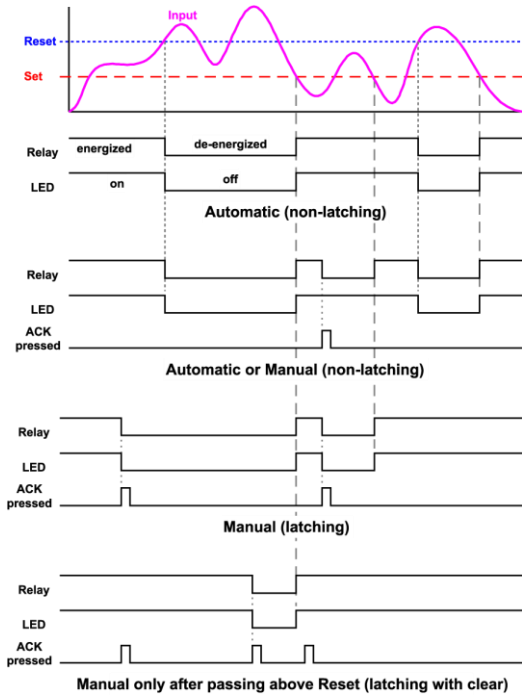

For Manual reset mode, ACK can be pressed anytime to turn "off" relay. For relay to turn back "on", signal must go above set point and then go below it.

Low Alarm with Fail-Safe Operation (Set < Reset)

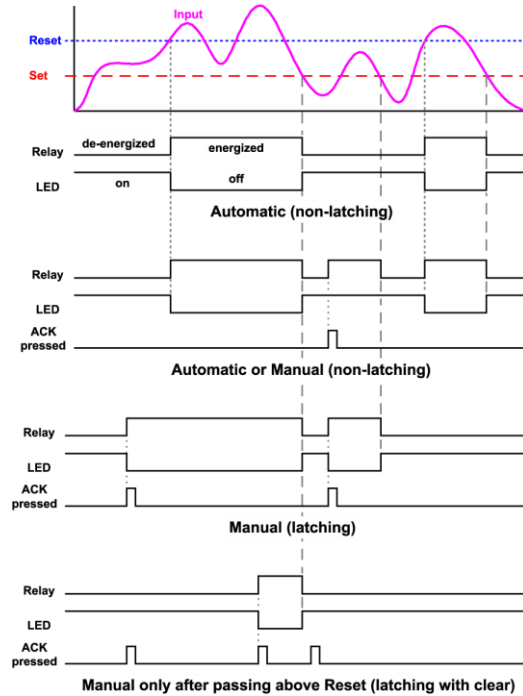

Note: Relay coil is energized in non-alarm condition. In case of power failure, relay will go to alarm state.

High Alarm with Fail-Safe Operation (Set > Reset)

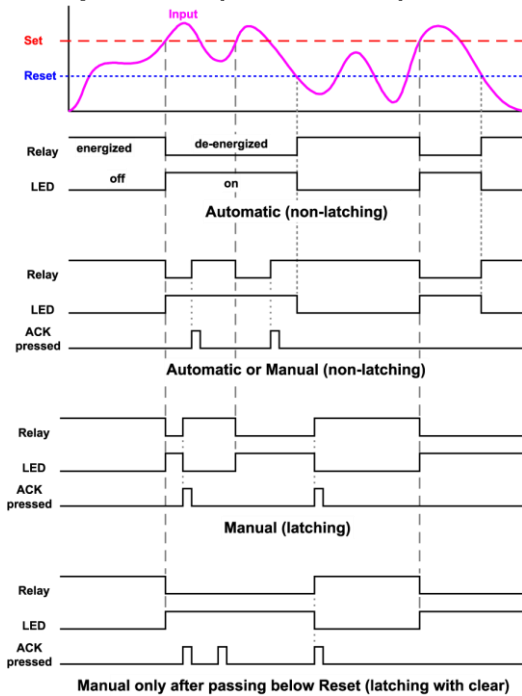

Note: Relay coil is energized in non-alarm condition. In case of power failure, relay will go to alarm state.

Time Delay Operation

The following graphs show the operation of the time delay function.

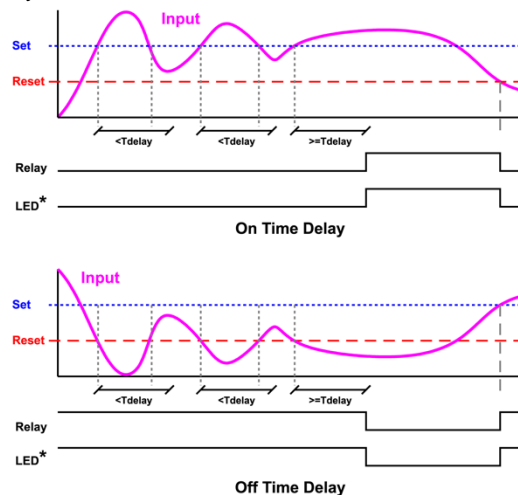

When the signal crosses the set point, the *On* time delay timer starts and the relay trips when the time delay has elapsed. If the signal drops below the set point (high alarm) before the time delay has elapsed, the *On* time delay timer resets and the relay does not change state. The same principle applies to the *Off* time delay.

Note: If "Automatic or Manual (R - rRn)" reset mode is selected, the LED follows the reset point and not the relay state when the relay is acknowledged.

Pump Alternation Control Operation

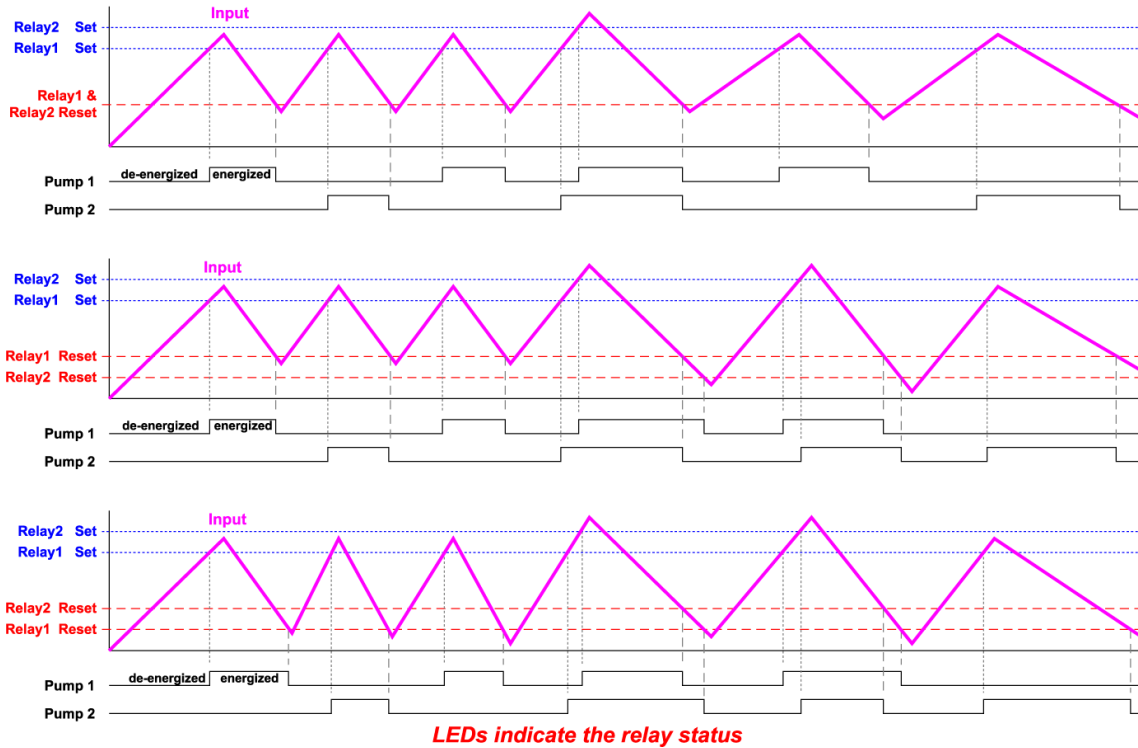

Relay Sampling Operation

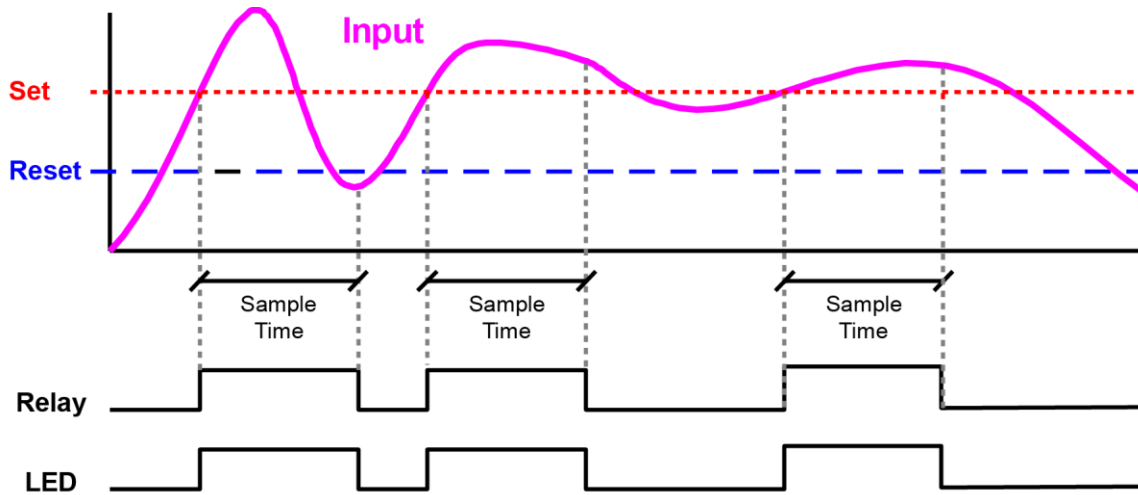

When the signal crosses the set point, the relay trips and the sample time starts. After the sample time has elapsed, the relay resets. The cycle repeats every time the set point is crossed, going up for high alarms and going down for low alarms.

The sample time can be programmed between 0.1 and 5999.9 seconds.

Relay Operation Details

Overview

The four-relays option for the meter expands its usefulness beyond simple indication to provide users with alarm and control functions. Typical applications include high and low force, level, or pressure alarms, control applications such as simple on/off control, and relay alternation control for up to 4 pumps. There are four basic ways the relays can be used:

1. High and Low Alarms with Latching or Non-Latching Relays
2. Simple On/Off Control with 100% Adjustable Deadband
3. Sampling (Based on Time)
4. Alternation Control for up to 4 Pumps

Relays Auto Initialization

When power is applied to the meter, the front panel LEDs and alarm relays will reflect the state of the input to the meter. The following table indicates how the alarm LEDs and relays will react on power-up based on the set and reset points.

Alarm #	HI or LO Alarm	Set Point	Reset Point	Power-Up Reading	Relay & LED
1	HI	1000	500	499	Off
2	LO	700	900	499	On
3	LO	250	400	499	Off
4	HI	450	200	499	On

Fail-Safe Operation

The following table indicates how the relays behave based on the fail-safe selection for each relay:

Fail-Safe Selection	Non-Alarm State		Alarm State		Power Failure
	NO	NC	NO	NC	
Off	Open	Closed	Closed	Open	Relays go to non-alarm state
On	Closed	Open	Open	Closed	Relays go to alarm state

Note: NO = Normally Open, NC = Normally Closed. This refers to the condition of the relay contacts when the power to the meter is off.

Front Panel LEDs

The alarm status LEDs on the front panel are available on all meters, even those without relays installed, and provide status indication for the following:

LED	Status
1	Alarm 1
2	Alarm 2
3	Alarm 3
4	Alarm 4

The meter is supplied with four alarm points that include front panel LEDs to indicate alarm conditions. This standard feature is particularly useful for alarm applications that require visual-only indication. The LEDs are controlled by the set and reset points programmed by the user. When the display reaches a set point for a high or low alarm, the corresponding alarm LED will turn on. When the display returns to the reset point the LED will go off. The front panel LEDs respond differently for latching and non-latching relays.

For non-latching relays, the LED is always off during normal condition and always on during alarm condition, regardless of the state of the relay (e.g. Relay acknowledged after alarm condition).

For latching relays, the alarm LEDs reflect the status of the relays, regardless of the alarm condition. The following tables illustrate how the alarm LEDs function in relation to the relays and the acknowledge button (Default: F3 key assigned to ACK).

Latching and Non-Latching Relay Operation

The relays can be set up for latching (manual reset) or non-latching (automatic reset) operation.

Relay terminology for following tables	
Terminology	Relay Condition
On	Alarm (Tripped)
Off	Normal (Reset)
Ack	Acknowledged

The On and Off terminology does not refer to the status of the relay's coil, which depends on the fail-safe mode selected.

WARNING

- In latching relay mode, if Fail-Safe is off, latched relays will reset (unlatch) when power is cycled.

Non-Latching Relay (ᑭᓂᓂ)

In this application, the meter is set up for automatic reset (non-latching relay). Acknowledging the alarm while it is still present has no effect on either the LED or the relay. When the alarm finally goes away, the relay automatically resets and the LED also goes off.

Automatic reset only		
Condition	LED	Relay
Normal	Off	Off
Alarm	On	On
Ack (No effect)	On	On
Normal	Off	Off

Non-Latching Relay with Manual Reset (ᑭ-ᑎᑎᑭᑎ)

In this application, the meter is set up for automatic and manual reset at any time (non-latching relay). The LED and the relay automatically reset when the meter returns to the normal condition.

In addition, the relay can be manually reset while the alarm condition still exists, but the LED will stay on until the meter returns to the normal condition.

Automatic + manual reset at any time		
Condition	LED	Relay
Normal	Off	Off
Alarm	On	On
Normal	Off	Off
Next Alarm	On	On
Ack	On	Off
Normal	Off	Off

Latching Relay (ᑭᑭᓂᓂ)

In this application, the meter is set up for manual reset at any time. Acknowledging the alarm even if the alarm condition is still present resets the relay and turns off the LED.

Manual reset any time		
Condition	LED	Relay
Normal	Off	Off
Alarm	On	On
Ack	Off	Off

Latching Relay with Clear (ᑭᑭ-ᑭᑭᑭ)

In this application, the meter is set up for manual reset only after the signal passes the reset point (alarm condition has cleared). Acknowledging the alarm while it is still present has no effect on either the LED or the relay. When the alarm is acknowledged after it returns to the normal state, the LED and the relay go off. Notice that the LED remains on, even after the meter returns to the normal condition. This is because, for latching relays, the alarm LED reflects the status of the relay, regardless of the alarm condition.

Manual reset only after alarm condition has cleared		
Condition	LED	Relay
Normal	Off	Off
Alarm	On	On
Ack (No effect)	On	On
Normal	On	On
Ack	Off	Off

Acknowledging Relays

There are three ways to acknowledge relays programmed for manual reset:

1. Via the programmable front panel function keys F1-F3 (Example: F3 assigned to ACK).

Note: If F3 is assigned to ACK, then it cannot be used for Tare.



2. Remotely via a normally open push button wired to the F4 terminal.

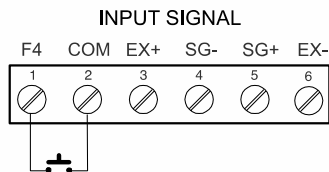

3. Remotely via a normally open push button wired to one of the digital inputs and the +5 V terminal on the digital I/O connections.

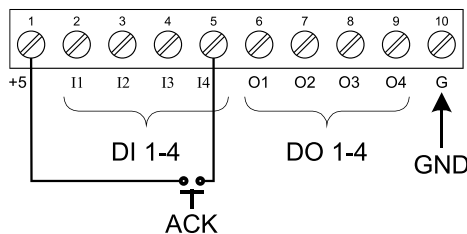

When the ACK button or the assigned digital input is closed, all relays programmed for manual reset are acknowledged.

Pump Alternation Control Applications (RLLErn)

For pump control applications where two or more similar pumps are used to control the level of a tank, it is desirable to have all the pumps operate alternately. This prevents excessive wear and overheating of one pump over the lack of use of the other pumps.

Up to 4 relays can be set up to alternate every time an on/off pump cycle is completed. The set points and reset points can be programmed, so that the first pump on is the first pump off.

Application #1: Pump Alternation Using Relays 1 & 2

1. Relays 1 and 2 are set up for pump alternation.
2. Relays 3 and 4 are set up for low and high alarm indication.

Set and Reset Point Programming			
Relay	Set Point	Reset Point	Function
1	30.000	10.000	Controls pump #1
2	35.000	5.000	Controls pump #2
3	4.000	9.000	Controls low alarm
4	40.000	29.000	Controls high alarm

Pump Alternation Operation

1. Pump #1 turns on when level reaches 30.000, when level drops below 10.000 pump #1 turns off.
2. The next time level reaches 30.000, pump #2 turns on, when level drops below 10.000 pump #2 turns off.
3. If the level doesn't reach 35.000 pump #1 and pump #2 will be operating alternately.
4. If pump #1 cannot keep the level below 35.000 pump #2 will turn on at 35.000, then as the level drops to 10.000 pump #1 turns off, pump #2 is still running and shuts off below 5.000.
5. Notice that with the set and reset points of pump #2 outside the range of pump #1, the first pump on is the first pump to go off. This is true for up to 4 alternating pumps, if setup accordingly.
6. Relay #3 will go into alarm if the level drops below 4.000 and relay #4 will go into alarm if the level exceeds 40.000.
7. Adding the 4 external relays expansion module allows using the 4 SPDT internal relays for pump alternation and the 4 SPST external relays for high, high-high, low, and low-low alarm indication.

Application #2: Pump Alternation Using Relays 3 & 4

1. Relays 1 and 2 are set up for low and high alarm indication.
2. Relays 3 and 4 are set up for pump alternation.

Set and Reset Point Programming			
Relay	Set Point	Reset Point	Function
1	495	750	Controls low alarm
2	7500	6900	Controls high alarm
3	7000	900	Controls backup pump
4	6000	1000	Controls main pump

The following graphics provide a visual representation of a typical pump alternation application with high and low alarm monitoring:

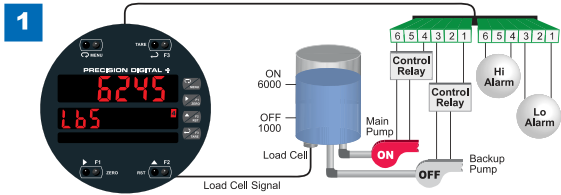

Relay #4 turns the main pump on at 6000 pounds and turns it off at 1000 pounds.

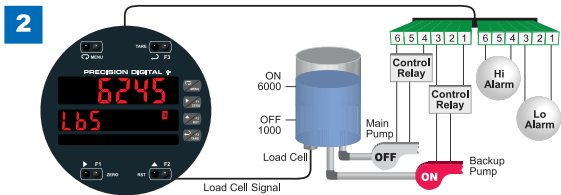

With the Pump Alternation feature activated, the next time the level reaches 6000 pounds, relay #3 transfers and starts the backup pump.

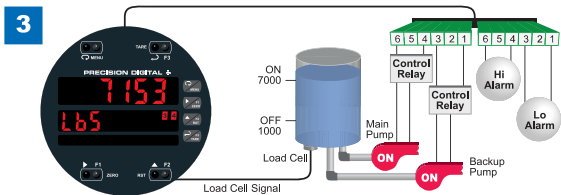

If the backup pump is not able to keep up, and the level reaches 7000 pounds, relay #4 transfers and starts the main pump as well.

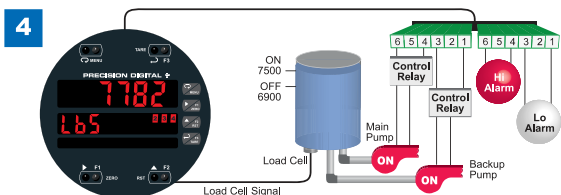

Relay #2 trips the High Level Alarm at 7500 pounds and resets at 6900 pounds.

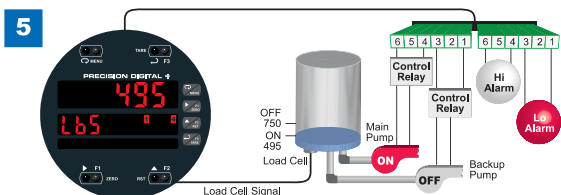

Relay #1 trips the Low Level Alarm at 495 pounds and resets at 750 pounds.

Setting Up the Interlock Relay (Force On) Feature

Relays 1-4 can be set up as interlock relays. To set up the relays for the interlock feature:

1. Access the *Setup – Relay – Action* menu and set the action to off.

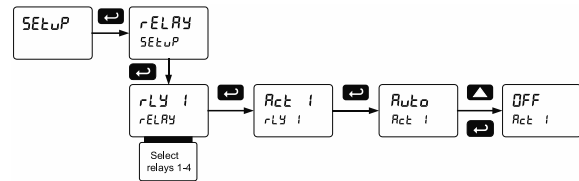

2. In the *Advanced features – User* menu program any of the digital inputs to *Force On* any of the internal relays (1-4).

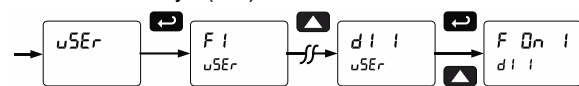

3. Connect a switch or dry contact between the +5V terminal and the corresponding digital input (DI-1 to DI-4) terminal.

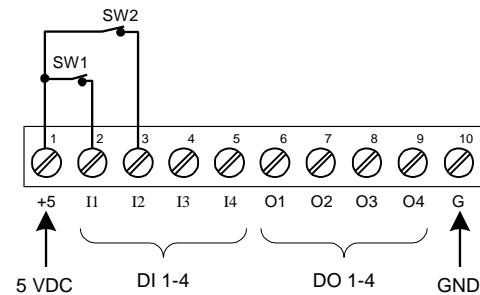

Interlock Relay Operation Example

Relays 1 & 2 are configured to energize (their front panel LEDs are steady on) when SW1 & SW2 switches (above) are closed. If the contacts to these digital inputs are opened, the corresponding front panel LEDs flash indicating this condition. The processes being controlled by the interlock relay will stop, and will re-start only after the interlock relay is re-activated by the digital inputs (switches).

Note: If multiple digital inputs are assigned to the same relay, then the corresponding logic is (AND) – i.e. both switches must be closed to activate the relay.

IMPORTANT

- If the digital inputs are assigned to the *Interlock Function*, then they cannot be used to program the meter remotely.

Scaling the 4-20 mA Analog Output (Rout)

The 4-20 mA analog output can be scaled to provide a 4-20 mA signal for any display range selected.

No equipment is needed to scale the analog output; simply program the display values to the corresponding mA output signal.

The *Analog Output* menu is used to program the 4-20 mA output based on display values.

For instructions on how to program numeric values see *Setting Numeric Values* on page 34.

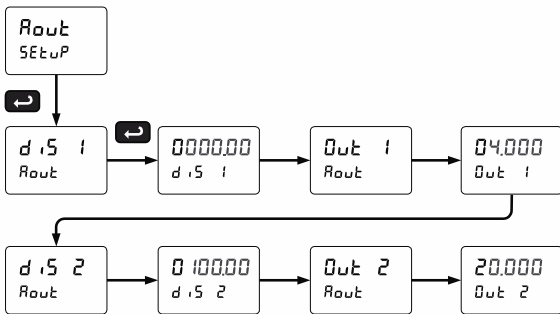

Reset Menu (rESEt)

The *Reset* menu is used to reset the tare (r5t t r) and the maximum or minimum readings (peak or valley) reached by the process; max & min may be reset at the same time by selecting “reset high & low” (r5t HL).

Note: Resetting the tare resets the max & min readings.

Tare Menu (tRrE)

The *Tare* menu is used to select the tare mode. There are three modes of operation: *Capture Tare*, *Programmable Tare*, and *Off*.

Capture Tare: Pressing the Tare key zeroes the display and the “T” indicator flashes indicating that tare is applied to the reading (e.g. Net weight).

Programmable Tare: Program a known value to be subtracted from the display value to obtain the net value. Pressing Reset tare clears the tare value to zero. Programmable Tare will not tare negative PVs. Use Capture Tare for negative PVs.

Off: Tare function is disabled and pressing Tare key has no effect.

Tare Functionality (tRrE)

The tare function zeroes out the display. In the case of scale weight, tare is used to eliminate container weight and provide net weight readings.



Manual Control Menu (Control)

The *Manual Control* menu is used to control the 4-20 mA analog output and the relays manually, ignoring the input. Each relay and analog output can be programmed independently for manual control. Selecting automatic control sets all relays and analog output for automatic operation.

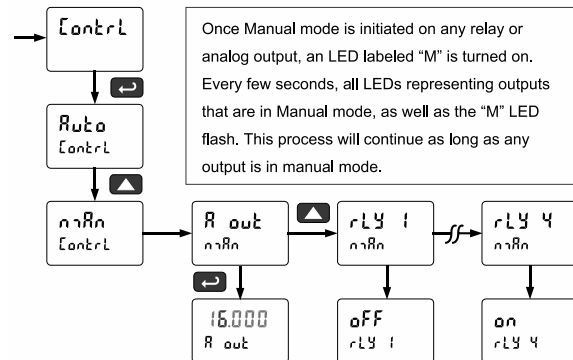

Setting Up the Password (PR55)

The *Password* menu is used for programming three levels of security to prevent unauthorized changes to the programmed parameter settings.

- Pass 1: Allows use of function keys and digital inputs
- Pass 2: Allows use of function keys, digital inputs and editing set/reset points
- Pass 3: Restricts all programming, function keys, and digital inputs.

Protecting or Locking the Meter

Enter the *Password* menu and program a six-digit password.

For instructions on how to program numeric values see *Setting Numeric Values* on page 34.

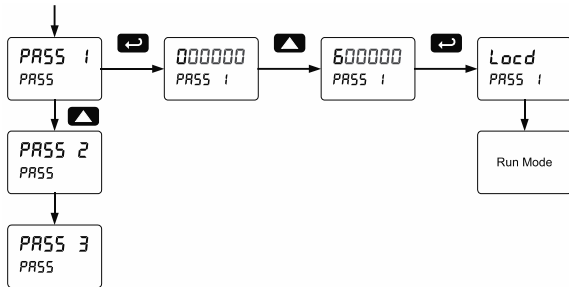

Making Changes to a Password Protected Meter

If the meter is password protected, the meter will display the message *Locd* (*Locked*) when the Menu button is pressed. Press the Enter button while the message is being displayed and enter the correct password to gain access to the menu. After exiting the programming mode, the meter returns to its password protected condition.

Disabling Password Protection

To disable the password protection, access the *Password* menu and enter the correct password twice, as shown below. The meter is now unprotected until a new password is entered.

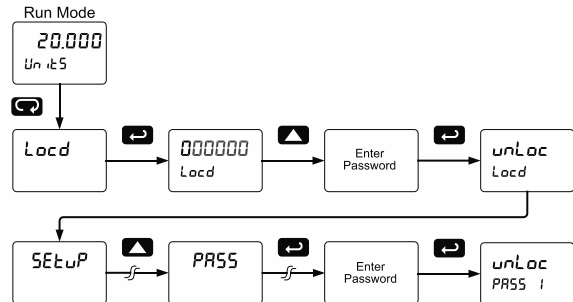

If the correct six-digit password is entered, the meter displays the message *unLoc* (*unlocked*) and the protection is disabled until a new password is programmed.

If the password entered is incorrect, the meter displays the message *Locd* (*Locked*) for about two seconds, and then it returns to Run Mode. To try again, press Enter while the *Locked* message is displayed.

Did you forget the password?

The password may be disabled by entering a master password once. If you are authorized to make changes, enter the master password 508655 to unlock the meter.

Advanced Features Menu

To simplify the setup process, functions not needed for most applications are located in the *Advanced Features* menu.

Press and hold the Menu button for three seconds to access the advanced features of the meter.

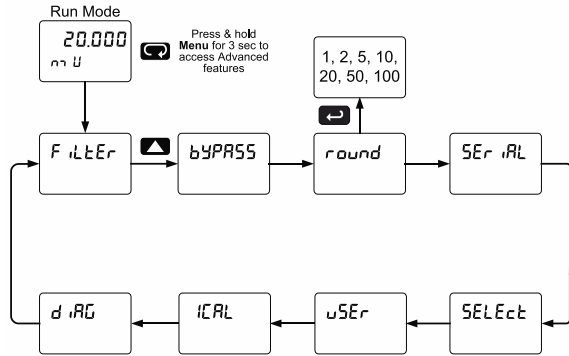

Advanced Features Menu & Display Messages

The following table shows the functions and messages of the *Advanced Features* menu in the order they appear in the menu.

Advanced Features Menu & Display Messages		
Display	Parameter	Action/Setting
F ILtEr	Filter	Set noise filter value
bYPASS	Bypass	Set filter bypass value
rOund	Rounding	Select rounding value
SErIAL	Serial	Set serial communication parameters
SlAVE ID	Slave ID	Set slave ID or meter address
bAUD	Baud rate	Select baud rate
tR dLY	Transmit delay	Set transmit delay for serial communication
PRr dLY	Parity	Select parity Even, Odd, or None with 1 or 2 stop bits
t-bYtE	Time byte	Set byte-to-byte timeout
SELEct	Select	Enter the Select menu (function, cutoff, out)
FunctiOn	Input signal conditioning	Linear, select number of points
L inERr	Linear	Set meter for linear function and select number of linearization points
PV 1	PV1	Select PV1 number of linearization points
PV 2	PV2	Select PV2 number of linearization points
nO Pts	Number of points	Set PV1 for 2 to 32-point linearization Set PV2 for 2 to 8-point linearization

Advanced Features Menu & Display Messages		
Display	Parameter	Action/Setting
SCALE	Scale	Scaling parameter
SCALE 1	Scale 1	Scaling parameter 1
SCALE 2	Scale 2	Scaling parameter 2
CuTtOFF	Cutoff	Set low-value cutoff
Auto 0	Auto Zero	Enter the Auto Zero function (on/off)
RoutePr	Analog output programming	Program analog output parameters
Source	Source	Select source for the 4-20 mA output
OverRng	Overrange	Program mA output for display overrange
Underrng	Underrange	Program mA output for display underrange
max	Maximum	Program maximum mA output allowed
min	Minimum	Program minimum mA output allowed
CALib	Calibrate	Calibrate 4-20 mA output (internal reference source used for scaling the output)
4 mA	4 mA output	Enter mA output value read by milliamp meter with at least 0.001 mA resolution
20 mA	20 mA output	Enter mA output value read by milliamp meter with at least 0.001 mA resolution
uSER	User I/O	Assign function keys and digital I/O
F1	F1 function key	Assign F1 function key (*F1/F2/F3)
F4	F4 function	Assign F4 function (digital input)
d i 1	Digital input 1	Assign digital input 1 – 4
d o 1	Digital output 1	Assign digital output 1 – 4
ICAL	Internal source calibration	Enter internal source calibration (used for scaling the meter without a signal source)
15mV	15 mV calibration	Calibrate 15 mV input range (internal reference source used for scaling the input)
30mV	20 mV calibration	Calibrate 30 mV input range (internal reference source used for scaling the input)
150mV	100 mV calibration	Calibrate 150 mV input range (internal reference source used for scaling the input)

Advanced Features Menu & Display Messages		
Display	Parameter	Action/Setting
200mV	200 mV calibration	Calibrate 300 mV input range (internal reference source used for scaling the input)
Strain OFF	Strain offset	Calibrate the offset of the input circuit
mV Lo	mV low	Calibrate low mV input (e.g. 0 mV)
mV Hi	mV high	Calibrate high mV input (e.g. 100 mV)
diagn	Diagnostics	Display test and information
LED test	LED test	Test all LEDs
Info	Information	Display software number and version
Erase	Erase	Erase MeterView Pro software stored in meter's memory

Noise Filter (FILT)

The noise filter is available for unusually noisy signals that cause an unstable process variable display. The noise filter averages the input signal over a certain period. The filter level determines the length of time over which the signal is averaged. The filter level can be set between 2 and 199. The higher the filter level, the longer the averaging time and so the longer it takes the display to settle to its final value. Setting the filter level to zero disables the filter function.

Noise Filter Bypass (bypass)

The noise filter bypass changes the behavior of the meter so that small variations in the signal are filtered out but large abrupt changes in the input signal are displayed immediately. The bypass value determines the minimum amount of signal change to be displayed immediately. All signal changes smaller than the bypass value are filtered or averaged by the meter. The noise filter bypass may be set between 0.1 and 99.9% of full scale.

Rounding Feature (round)

The rounding feature is used to give the user a steadier display with fluctuating signals. Rounding is used in addition to the filter function.

Rounding causes the display to round to the nearest value according to the rounding selected. See examples below:

Rounding Selection	Actual Value	Display Value	Actual Value	Display Value
1	12.022	12.022	12.023	12.023
5	12.022	12.020	12.023	12.025
10	12.024	12.020	12.025	12.030

Modbus RTU Serial Communications (SERIAL)

The meter is equipped with serial communications capability as a standard feature using Modbus RTU Serial Communication Protocol.

The meter may be connected to a PC for initial configuration via the onboard USB connection. For ongoing digital communications with a computer or other data terminal equipment, use the RS-485 connection with the appropriate serial converter; see *Ordering Information* on page 7 for details.

CAUTION

- **DO NOT** connect any equipment to the RJ45 M-LINK connector. Otherwise damage will occur to the equipment and the meter.
- **DO NOT** disconnect the RJ45 connector located to the left of the power terminal block. Doing so will disable the on-board digital I/O, and the RS-485 serial communications.

Notes:

1. More detailed instructions are provided with each optional serial communications adapter.
2. Refer to the ProtEX-MAX Modbus Register Tables located at www.predig.com for details.

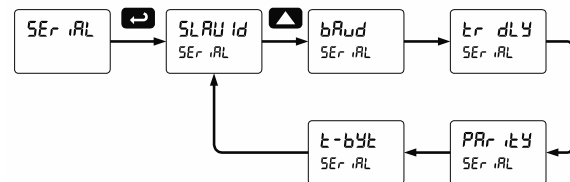

When using more than one meter in a multi-drop mode, each meter must be provided with its own unique address. The meter address (Slave ID) may be programmed between 1 and 247. The transmit delay may be set between 0 and 199 ms. The parity can be set to even, odd, or none with 1 or 2 stop bits.

Select Menu (SELEct)

The *Select* menu is used to select the input signal conditioner applied to the input (linear), low-value cutoff, Auto-zero, and analog output programming. The multi-point linearization is part of the linear function selection.

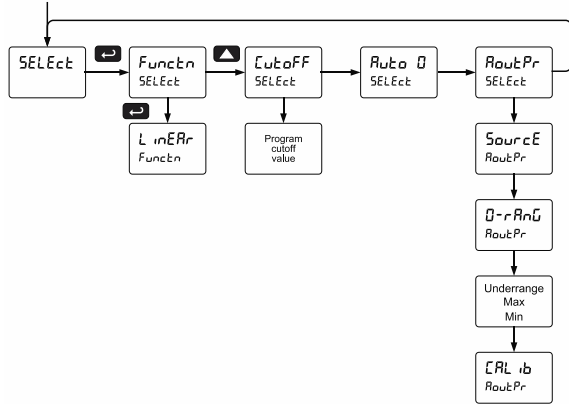

Input Signal Conditioning (Functn)

The *Function* menu is used to select the input signal conditioner applied to the input: linear. The multi-point linearization is part of the linear function selection. Meters are set up at the factory for linear function with 2-point linearization. The linear function provides a display that is linear with respect to the input signal.

Multi-Point Linearization (L inERr)

Meters are set up at the factory for linear function with 2-point linearization. Up to 32 linearization points can be selected for PV under the linear function. The multi-point linearization can be used to linearize the display for non-linear signals.

If the dual-scale Level feature has been selected, the menus for PV1 & PV2 are enabled. PV2 can be programmed with up to 8 linearization points.

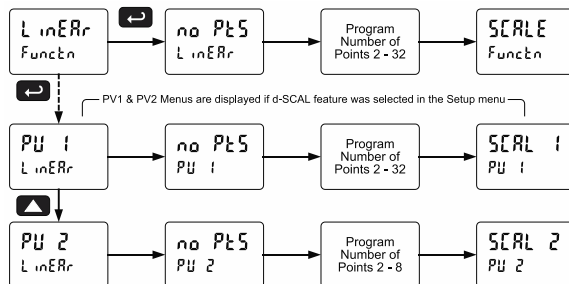

Auto-Zero (Auto 0)

Auto-zero corrects for drift that can occur over time that causes the input signal to slowly change. The meter will continue to read zero despite slow and small changes to the input signal. The auto-zero value represents the percent of full scale drift that the meter will correct.

Under normal circumstances, when the signal increases quickly, by an amount greater than the auto-zero percent of full scale, the value will not be adjusted. Slow signal changes that occur over time at increments less than the auto-zero value, will not register on the meter (example: dust on a load cell or sensor drift over time).

Auto-Zero Example

Scale	0.00 – 100.00
Auto-Zero	0.06

Changes less than 0.06 within 1 second are zeroed out. If the change is 0.10, then it is registered as a real signal change and the Auto-Zero function is bypassed.

Low-Value Cutoff (Cutoff)

The low-value cutoff feature allows the meter to be programmed so that below a certain value, the meter always displays zero.

The cutoff value may be programmed from 0.1 to 999999. The meter will display zero below the cutoff value. Programming the cutoff value to zero disables the cutoff feature. The cutoff can be disabled to display negative values.

Analog Output Programming (RoutPr)

The *Analog Output Programming* menu is used to program the behavior of the 4-20 mA output. The following parameters and functions are programmed in this menu:

1. Source: Source for generating the 4-20 mA output (e.g. PV)
2. Overrange: Analog output value with display in overrange condition
3. Underrange: Analog output value with display in underrange condition
4. Max: Maximum analog output value allowed regardless of input
5. Min: Minimum analog output value allowed regardless of input
6. Calibrate: Calibrate the internal 4-20 mA source reference used to scale the 4-20 mA output

Analog Output Source

The source for generating the 4-20 mA output may be assigned to the process variable, maximum or minimum value reached by the process, one of the set points, or the Modbus PV input.

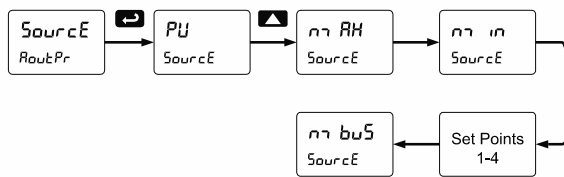

Analog Output Calibration

To perform the analog output calibration, it is recommended to use a milliamp meter with a resolution of at least 0.1 μ A to measure the output current. The values saved internally during this procedure are used for scaling the 4-20 mA output in the *Setup* menu.

Analog Output Calibration Procedure

1. Wire the PD8-6100 4-20 mA output to a current loop that includes a power supply (internal or external 12 to 24 VDC), and the mA input on the digital meter. See *Figure 21. 4-20 mA Output Connections* on page 29 for details.
2. Turn on all devices. Allow for a 15 to 30 minute warm-up.
3. Go to the Advanced Features menu, navigate to Select (SELE) and choose Analog Output Programming (RoutPr)/Calibration (CALIB) menu and press **Enter**.
4. The display will show 4 mA. The PD8-6100 mA output should now be close to 4 mA. Press **Enter** and the display will show 04.000. Enter the actual value read by the digital mA meter and press **Enter**.
5. The display will show 20 mA. The PD8-6100 mA output should now be close to 20 mA. Press **Enter** and the display will show 20.000. Enter the actual value read by the digital mA meter and press **Enter**.
6. The meter will now calculate the calibration factors and store them.
7. Press **Menu** to exit and return to Run mode.

Programmable Function Keys User Menu (uSEr)

The *User* menu allows the user to assign the front programming buttons function keys F1, F2, and F3, the digital input F4 (located on the input signal connector), and four digital inputs (located on the digital I/O connector) to access most of the menus or to activate certain functions immediately (e.g. reset max & min, hold relay states, etc.). This allows the meter to be greatly customized for use in specialized applications.

The four digital outputs can be assigned to a number of actions and functions executed by the meter (i.e. alarms, relay acknowledgement, reset max, min, or max & min, tare, and reset tare). The digital outputs can be used to trigger external alarms or lights to indicate these specific events.

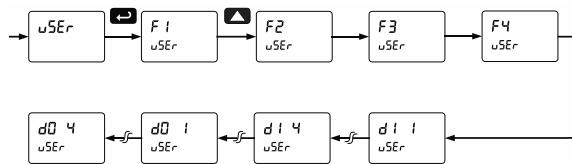

Function Keys & Digital I/O Available Settings

Refer to the following table for descriptions of each available function key or digital I/O setting.

Function Keys & Digital I/O Available Settings	
Display	Description
rSE H i	Reset the stored maximum display value
rSE Lo	Reset the stored minimum display value
rSE HL	Reset the stored maximum & minimum display values
tRE E	Capture tare and zero the display
rSE tr	Reset captured tare and resume normal operation
rELRY	Directly access the relay menu
SEt I*	Directly access the set point menu for relay 1 (*through 4)
rLY d	Disable all relays until a button assigned to <i>enable relays</i> (rLY E) is pressed
rLY E	Enable all relays to function as they have been programmed
H HoLd	Hold current relay states and analog output as they are until a button assigned to <i>enable relays</i> (rLY E) is pressed
d HoLd	Hold the current display value, relay states, and analog output momentarily while the function key or digital input is active. The process value will continue to be calculated in the background.
Ln i H i	Display minimum display value on line 1

Function Keys & Digital I/O Available Settings	
Display	Description
Ln i Lo	Display minimum display value on line 1
Ln i HL	Display maximum & minimum display values on line 1
Ln2 mV	Display the mV input on line 2
Ln2 H i	Display maximum display value on line 2
Ln2 Lo	Display minimum display value on line 2
Ln2 HL	Display maximum & minimum display values on line 2
ZEr o	Zero the display (this is different from <i>capture tare</i> because it cannot be reset)
F On I*	Force relay 1 (*through 4) into the on state. This function is used in conjunction with a digital input to achieve interlock functionality. See <i>Setting Up the Interlock Relay (Force On) Feature</i> on page 47 for details about interlock relays.
CoNt rL	Directly access the <i>Manual Control</i> menu
d iSAbL	Disable the selected function key or digital I/O
RcH	Acknowledge all active relays that are in a manual operation mode such as auto-manual or latching
rESEt	Directly access the reset menu
o rEnu	Mimic the menu button functionality (digital inputs only)
r rGHt	Mimic the right arrow/F1 button functionality (digital inputs only)
uP	Mimic the up arrow/F2 button functionality (digital inputs only)
En tEr	Mimic the enter/F3 button functionality (digital inputs only)
RL n r I*	Provide indication when alarm 1 (*through 4) has been triggered (digital outputs only)

Internal Source Calibration (CAL)

There is **no need to recalibrate** the meter when first received from the factory.

The meter is **factory calibrated** prior to shipment for millivolts with calibration equipment that is certified to NIST standards.

The internal source allows the user to scale the meter without applying a signal.

The use of calibrated signal sources is necessary to perform the internal source calibration of the meter.

Check calibration of the meter at least every 12 months. Each range must be recalibrated separately.

Notes:

1. mV input: If meter is in operation and it is intended to accept only one input range (e.g. 0-30 mV), recalibration of other ranges is not necessary.
2. Strain gauge: If the meter is intended to accept a strain gauge bridge input, it is recommended to use the CAL function with ratiometric compensation turned on.
3. Allow the meter to warm up for at least 15 minutes before performing the internal source calibration procedure.

The *Internal calibration* menu is part of the *Advanced Features* menu.

1. Press and hold the Menu button for three seconds to access the advanced features of the meter.
2. Press the Up arrow button to scroll to the *Internal calibration* menu (CAL) and press Enter.
3. The meter displays the first input range (LOW), press the Up arrow to select any other range (e.g. HIGH). Press Enter to start the calibration process.

Example of Internal Calibration for 100 mV input range:

4. The meter displays the message "StrOff" (strain offset), short the SG+, SG- terminals and press Enter. The low input message is displayed (LOW). Apply the low input signal (e.g. 0.00 mV) and press Enter. The display flashes for a moment while the meter is accepting the low input signal.
5. After the display stops flashing, a number is displayed with the leftmost digit brighter than the rest. The bright digit is the active digit that can be changed by pressing the Up arrow button. Press the Right arrow button to move to the next digit.
6. Set the display value to correspond to the input signal being calibrated; typically 0.00 mV.
7. The display moves to the *high* input calibration (HIGH). Apply the high input signal and press Enter.
8. Set the display for the high input calibration, in the same way as it was set for the low input calibration, typically 100.00 mV.

The following graphic shows the calibration of the 100 mV input range. The other ranges are calibrated in a similar way.

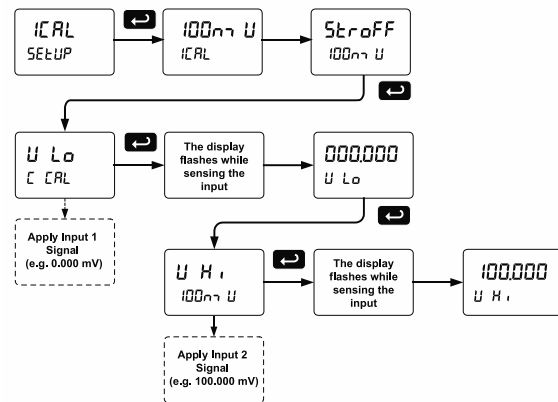

Tips:

- Low and high input signals can be any valid values within the range of the meter.
- Observe minimum input span requirements between input 1 and input 2.
- Low input should be less than high input signal.

Error Message (Error)

An error message indicates that the calibration or scaling process was not successful.

After the error message is displayed, the meter reverts to input 2 during calibration or scaling and to input 1 during internal calibration, allowing the appropriate input signal to be applied or programmed.

The error message might be caused by any of the following conditions:

1. Input signal is not connected to the proper terminals, or it is connected backwards.
2. Wrong signal selection in *Setup* menu.
3. Minimum input span requirements not maintained.

Minimum Input Span

The minimum input span is the minimum difference between input 1 and input 2 signals required to complete the calibration or scaling of the meter.

Input Range	Input 1 & Input 2 Span
15 mV	0.2 mV
25 mV, 30 mV	0.4 mV
150 mV	2.0 mV
250 mV, 300 mV	4.0 mV

Meter Operation

When installed, the primary way to operate the meter is with the SafeTouch through-glass buttons that allow the user to perform various operations without removing the cover and exposing the electronics to the hazardous environment. The user can also operate the meter by connecting a hazardous area-approved control station or switch to one of the digital inputs. These can be used to perform various operations on the meter based on the Programmable Function Keys. Finally, certain operations can be performed on the meter with MeterView Pro software or through Modbus commands.

The three default operations that can be performed with the meter's SafeTouch buttons are:





1. Zero the meter
2. Reset the tare
3. Tare the display value

In addition, the user can program the SafeTouch Buttons to perform a variety of useful operations by reassigning them to other functions per *Function Keys & Digital I/O Available Settings* on page 54.

Watch Batch Control Video at
www.prediq.com/videos/KN6Y6R0I0E

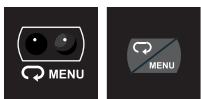
Button Operation

The following table shows the default operations for the F1, F2, and F3 SafeTouch Buttons: zero the meter, reset the tare, and tare the display value.

Button Symbol	Description
	Press to enter or exit Programming Mode or view settings
	Press to zero the meter or other parameter/function assigned through the <i>User</i> menu
	Press to reset tare or other parameter/function assigned through the <i>User</i> menu
	Press to tare the display value or other parameter/function assigned through the <i>User</i> menu



To learn more about SafeTouch buttons, see this video:

prediq.com/videos/Safetouch_Buttons

SafeTouch Buttons

The ProtEX-MAX is equipped with four sensors that operate as through-glass buttons so that it can be programmed and operated without removing the cover (and exposing the electronics) in a hazardous area.

These buttons can be disabled for security by selecting DISABLE on the switch labeled NO-CONTACT BUTTONS located on the connector board.



To actuate a button, press one finger to the glass directly over the marked button area. Then retract finger more than three inches from the glass before pressing the next button. When the cover is removed, the four mechanical buttons located next to the sensors are used. The sensors are disabled when a mechanical button is pressed and will automatically be re-enabled after 60 seconds of inactivity.

The SafeTouch Buttons are designed to filter normal levels of ambient interference and to protect against false triggering, however, it is recommended that the SafeTouch Buttons be disabled (slide switch to DISABLE) if there is an infrared interference source in line-of-sight to the display.

The SafeTouch Buttons are configured by default to duplicate the function of the front panel mechanical pushbuttons associated with the integrated controller. The symbols by each SafeTouch button correspond to a mechanical button as shown in the table to the left.

SafeTouch Button Tips:

- To the extent possible, install the display facing away from sunlight, windows, reflective objects and any sources of infrared interference.
- Keep the glass window clean.
- Tighten the cover securely.
- Use a password to prevent tampering.

Function Keys Operation

During operation, the programmable function keys operate according to the way they have been programmed in the *Advanced Features – User* menu. See *Programmable Function Keys User Menu (u5Er)* on page 54 for details.

The table above shows the factory default settings for F1, F2, and F3.

Digital Inputs Operation

Five (5) digital inputs, F4, DI-1 to DI-4, come standard on the meter. These digital inputs are programmed identically to function keys F1, F2, and F3. The inputs are triggered with a contact closure to +5 V in the case of digital inputs 1-4 or with an active high signal, see *Digital I/O Connections* on page 29 for details. The F4 is triggered with a contact closure to COM or with an active low signal. During operation, digital inputs operate according to the way they are programmed in the *Advanced Features – User* menu. See *Programmable Function Keys User Menu (u5Er)* on page 54 for details.

Maximum/Minimum Readings

The max & min readings (peak & valley) reached by the process can be displayed either continuously or momentary:

1. Display briefly by assigning to the F1-F3 function keys or to the digital inputs in the *User* menu. Any of the F1-F3 function keys (buttons) and the digital inputs can be programmed to reset the max & min readings.
2. Display continuously by assigning either display to max/min through the *Display* menu.

To display max reading using function key:

1. Press user assigned function key/digital input to display maximum reading since the last reset/power-up.
2. To reset max/min, press the Menu button, then the Up arrow/F2 button until the Reset (rE5E) menu is displayed.
3. Press the Up arrow/F2 button to select reset high (r5E H), reset low (r5E L), or reset high and low (r5E HL) is displayed and then press the Enter/F3 button. The max and/or min displays are reset to actual values.
4. Press Menu to exit max/min display reading.

To display max/min readings continuously:

Assign either display to Max (d H), Min (d L), or toggle between Max and Min (d HL) every 10 seconds.

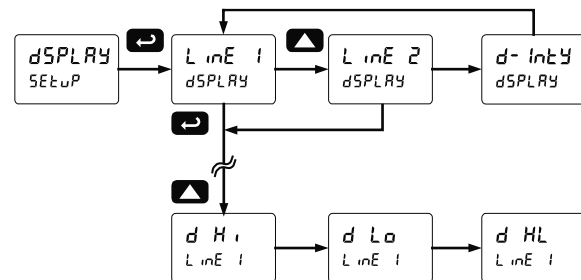

Troubleshooting

Due to the many features and functions of the meter, it's possible that the setup of the meter does not agree with what an operator expects to see. If the meter is not working as expected, refer to the *Diagnostics* menu and consult the recommendations described below.

Diagnostics Menu (d ,RG)

The *Diagnostics* menu is located in the *Advanced Features* menu, to access *Diagnostics* menu see *Advanced Features Menu* on page 50.

This menu allows the user to test the functionality of all the meter LEDs, check the meter's software and version information, and erase the MeterView Pro software installation files from the meter. Press the Enter button to view the settings and the Menu button to exit at any time.

For a description of the diagnostic messages, see *Advanced Features Menu & Display Messages* on page 50.

Testing the Display LEDs

To test all LEDs on the display:

1. Go to the *Diagnostics* menu (d ,RG) and press Enter button.
2. Press Up arrow button and scroll to *LED Test* menu (LED t)
3. Press the Enter button to activate the LED Test. The meter will cycle through all digits, decimal points, and relay indicators to enable the operator to check that all LEDs are functioning properly.
4. Press the Enter button again to access the *Information* menu (inFa) or press the Menu button to return to Run Mode.

Determining Software Version

To determine the software version of a meter:

1. Go to the *Diagnostics* menu (d ,RG) and press Enter button.
2. Press Up arrow button and scroll to *Information* menu (inFa).
3. Press Enter to access the software number (SFt) and version (UR) information. Write down the information as it is displayed. Continue pressing Enter until all the information is displayed.
4. The meter returns to Run Mode after displaying all the settings.

Reset Meter to Factory Defaults

When the parameters have been changed in a way that is difficult to determine what's happening, it might be better to start the setup process from the factory defaults.

Instructions to load factory defaults:

1. Enter the *Advanced Features* menu. See *Advanced Features Menu* on page 50.
2. Press Up arrow to go to *Diagnostics* menu
3. Press and hold Right arrow for three seconds, press Enter when display flashes rESEt.
Note: If Enter is not pressed within three seconds, the display returns to the *Diagnostics* menu.
4. The meter goes through an initialization sequence (similar as on power-up), and loads the factory default settings.

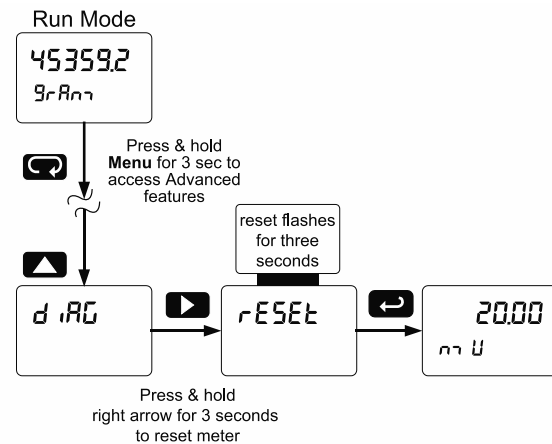

Factory Defaults & User Settings

The following table shows the factory setting for most of the programmable parameters on the meter.

Parameter	Display	Default Setting
Input type	POLAR	Polar = Uni
Input Range	RANGE	Range = 30mV
Ratiometric	RATIO	Ratio = Yes
Dual-scale	DSCALE	No (Single scale)
Filter	FILTER	70
Bypass	BYPASS	0.2
Rounding	ROUND	1
Function	FUNCTION	Linear
Number of points	NOPTS	2
Programming	PRGM	Scale
Input 1	INP 1	0.00 mV
Display 1	DIS 1	0.00
Input 2	INP 2	100.00 mV
Display 2	DIS 2	100.00
Decimal point	DDDDDD	3 places
Cutoff value	CUTOFF	0.0 (disabled)
Auto-zero	AUTO Z	0.05% of Full Scale
Display assignment	DISPLAY	
Line 1	LINE 1	PV: Process variable
Line 2	LINE 2	Eng units: mV
Display intensity	DIINT	6
Relay 1 action	REL 1	Automatic
Relay 1 set point	SET 1	10.00
Relay 1 reset point	RST 1	5.00
Relay 2 action	REL 2	Automatic
Relay 2 set point	SET 2	20.00
Relay 2 reset point	RST 2	15.00
Relay 3 action	REL 3	Automatic
Relay 3 set point	SET 3	30.00
Relay 3 reset point	RST 3	25.00
Relay 4 action	REL 4	Automatic
Relay 4 set point	SET 4	40.00
Relay 4 reset point	RST 4	35.00
Fail-safe relay 1	FLS 1	Off
Fail-safe relay 2	FLS 2	Off
Fail-safe relay 3	FLS 3	Off
Fail-safe relay 4	FLS 4	Off

Parameter	Display	Default Setting
On delay relay 1	ON 1	0.0 sec
Off delay relay 1	OFF 1	0.0 sec
On delay relay 2	ON 2	0.0 sec
Off delay relay 2	OFF 2	0.0 sec
On delay relay 3	ON 3	0.0 sec
Off delay relay 3	OFF 3	0.0 sec
On delay relay 4	ON 4	0.0 sec
Off delay relay 4	OFF 4	0.0 sec
Display 1 analog out	DIS 1	0.00
Output 1 value	OUT 1	4.000 mA
Display 2 analog out	DIS 2	100.00
Output 2 value	OUT 2	20.000 mA
Source analog output	SOURCE	Process Variable
Overrange output	ORANGE	21.000 mA
Underrange output	UNDER	3.000 mA
Maximum output	MAX	23.000 mA
Minimum output	MIN	1.000 mA
Slave ID (Address)	SLAVE ID	247
Baud rate	BAUD	9600
Transmit delay	TR DEL	10 ms
Parity	PARITY	Even
Byte-to-byte timeout	BTBT	010 (0.1 sec)
F1 function key	F1	Zero
F2 function key	F2	Reset Tare
F3 function key	F3	Tare
F4 Function	F4	Acknowledge relays
Digital input 1	DI 1	Menu
Digital input 2	DI 2	Right arrow/F1
Digital input 3	DI 3	Up arrow/F2
Digital input 4	DI 4	Enter/F3
Digital output 1	DO 1	Alarm 1
Digital output 2	DO 2	Alarm 2
Digital output 3	DO 3	Alarm 3
Digital output 4	DO 4	Alarm 4
Password 1	PRSS 1	000000 (unlocked)
Password 2	PRSS 2	000000 (unlocked)
Password 3	PRSS 3	000000 (unlocked)

Troubleshooting Tips

This meter is a highly sophisticated instrument with an extensive list of features and capabilities. If the programming buttons are used to program the meter, it may be a difficult task to keep everything straight. That is why we strongly recommend the use of the free [MeterView Pro](#) software for all programming activities. A USB cable is provided with the meter for programming with MeterView Pro software.

If you have programmed the meter with the programming buttons and it is not working as intended, try re-programming the meter using MeterView Pro software.

Symptom	Check/Action
No display at all	Check power at power connector
Not able to change setup or programming, <i>Load</i> is displayed	Meter is password-protected, enter correct six-digit password to unlock or Master Password of 508655
Meter does not respond to input change	If a <i>Low-Value Cutoff</i> has been programmed, the meter will display zero below that point, regardless of the input – which can appear like the meter is not responding to an input change. Check to make sure the problem is not being caused by an undesired low-value cutoff setting. To prevent the display from showing a negative value, set the low-flow cutoff to a value greater than zero.
Meter displays error message during calibration (<i>Error</i>)	Check: 1. Signal connections 2. Input selected in <i>Setup</i> menu 3. Minimum input span requirements
Meter displays 1. 999999 2. -999999 3. Full	Check: 1. Input selected in <i>Setup</i> menu 2. Signal at Signal connector 3. Input exceeds range selected
Display is unstable	Check: 1. Input signal stability and value 2. Display scaling vs. input signal 3. Filter and bypass values (increase) 4. Increase Rounding value
Display response is too slow	Check filter and bypass values
Display reading is not accurate	Check: 1. Scaling or calibration 2. Change Line 2 to mV and check to make sure you are receiving the correct mV value from sensor
Display value is drifting over time with no load	Try increasing Auto-Zero value. See <i>Auto-Zero (Auto 0)</i> on page 52.
Display does not respond to input changes, reading a fixed number	Check display assignment, it might be displaying max, min, or set point
Display alternates between 1. Hi and a number 2. Lo and a number	Press Menu to exit max/min display readings
Relay operation is reversed	Check: 1. Fail-safe in <i>Setup</i> menu 2. Wiring of relay contacts
Relay and status LED do not respond to signal	Check: 1. Relay action in <i>Setup</i> menu 2. Set and reset points
Flashing relay status LEDs	Relays in manual control mode or relay interlock switches opened
Meter not communicating with application programs	Check: 1. Serial adapter and cable 2. Serial settings 3. Meter address and baud rate
If the display locks up or the meter does not respond at all	Cycle the power to reboot the microprocessor

Troubleshooting Tips

Symptom	Check/Action
SafeTouch buttons do not respond	<ol style="list-style-type: none"> 1. If mechanical button was pushed, the SafeTouch buttons will be re-enabled automatically 60 seconds after the last button push. 2. If slide switch on connector board is in DISABLE position, switch to ENABLE. 3. Strong direct sunlight may interfere with SafeTouch button operation. It is recommended to operate the buttons by standing so as to block direct sunlight.
Serial Communications METER LINK LED Indicator is off	Check: <ol style="list-style-type: none"> 1. Modular cable connection 2. Power to the device
If only the TX (or DATA IN) data status LED is flashing when serial communications attempted	Check: <ol style="list-style-type: none"> 1. Serial cable 2. Instrument address & baud rate 3. Program address & baud rate
If both data status LEDs (TX and RX) are off when trying to communicate	Remove all unnecessary cables and instruments from the bus. Try getting the system to work with only one device (to ease troubleshooting) and then expand the system one device at a time.
Communications slow	Increase the baud rate
Sensor is not receiving power from PD8-6100	Check and make sure Excitation (Switch 1) is set to ON for Internal Excitation. See <i>Excitation (Switch 1)</i> on page 25 for more details.
Random communication errors	<ol style="list-style-type: none"> 1. Increase the TX delay time 2. Decrease the baud rate
Other symptoms not described above	Call Technical Support for assistance.

Note: Certain sequences of events can cause unexpected results. To solve these issues, it is best to start fresh from factory defaults and use the manual as a step by step programming guide, rather than a random approach to programming. To reset the meter to factory defaults, see *Reset Meter to Factory Defaults* on page 58. In addition, for best results, we recommend using the free MeterView Pro software for all programming needs.

NOTES

Complete Product Line of Displays and Controllers IN ALL SHAPES, SIZES & LOCATIONS



Big, Bright Displays
For Indoor or Outdoor
in Bright Sunlight



Large Dual-Line
6-Digit Display



24 VDC
Transmitter
Power Supply



MeterView® Pro USB
Programming Software



Universal 85-265
VAC or 12-24 VDC
Input Power
Options



4-20 mA, 0-10 V,
Thermocouple, RTD,
Strain Gauge, High
Voltage, & Modbus Inputs



Up To Four
3 A Form C
Relays (SPDT)



EXPLOSION-PROOF ProtEX-MAX Series

- NEMA 4X, IP68 Rated Enclosure
- SafeTouch® Through-Glass Buttons
- Operating Temperature of -40 to 65°C
- Worldwide Approvals

LARGE DISPLAYS Helios Series

- 1.8" Digits Readable From 100 Feet
- NEMA 4X, IP65 Rated Enclosure
- Operating Temperature of -40 to 65°C
- Now UL and C-UL Approved!

PANEL METERS ProVu Series

- NEMA 4X, IP65 Rated Front
- Programmable Function Keys
- UL, C-UL, and CE Approvals
- 1/8 DIN Size

Go to PREDIG.COM for details on ProVu, ProtEX-MAX and Helios Series Meters

Contact Precision Digital

Technical Support

Call: (800) 610-5239 or (508) 655-7300

Fax: (508) 655-8990

Email: support@predig.com

Sales Support

Call: (800) 343-1001 or (508) 655-7300

Fax: (508) 655-8990

Email: sales@predig.com

Place Orders

Email: orders@predig.com

For the latest version of this manual please visit

www.predig.com

PRECISION DIGITAL CORPORATION

233 South Street • Hopkinton MA 01748 USA

Tel (800) 343-1001 • Fax (508) 655-8990

www.predig.com

