

PD8-6262 Explosion-Proof Dual Analog Input Rate/Totalizer

Instruction Manual



MeterView Pro

USB Install

- Fully-Approved Explosion-Proof Dual Analog Input Flow Rate/Totalizers
- 0-20 mA, 4-20 mA, 0-5 V, 1-5 V, and ± 10 V Inputs with $\pm 0.03\%$ Accuracy
- Dual Analog Inputs with Math Functions
- Rate, Total, and Grand Total for Each Input Channel
- Display Rate & Total at the Same Time
- Front Panel or Remote Total Reset
- Password Protection for Programming and Total Reset
- Total Stored in Non-Volatile Memory
- Dual-Line 6-Digit Display, 0.6" (15 mm) & 0.46" (12 mm)
- SafeTouch Through-Glass Button Programming
- Display Mountable at 0°, 90°, 180°, & 270°
- Isolated 24 VDC @ 25 mA Transmitter Power Supply
- Easy Field Scaling in Engineering Units without Applying an Input
- 4 Relays with Interlocking Capability + Isolated 4-20 mA Output Option
- Free PC-Based, On-Board, MeterView Pro USB Programming Software
- SunBright Display Standard Feature; Great for Outdoor Applications
- Operating Temperature Range: -40 to 60°C (-40 to 140°F)
- FM Approved as Explosion-Proof / Dust-Ignition-Proof / Flame-Proof
- CSA Certified as Explosion-Proof / Dust-Ignition-Proof / Flame-Proof
- ATEX and IECEx Certified as Flame-Proof
- Input Power Options: 85-265 VAC / 90-265 VDC or 12-24 VDC / 12-24 VAC
- 32-Point Linearization & Square Root Extraction
- Programmable Display, Function Keys & Digital Inputs
- Flanges for Wall or Pipe Mounting
- Explosion-Proof, IP68, NEMA 4X Die-Cast Aluminum Enclosure
- On-Board RS-485 Serial Communications
- Modbus RTU Communication Protocol Standard
- Four 3/4" NPT Threaded Conduit Openings (Two Plugs Installed)
- 3-Year Warranty

PRECISION DIGITAL CORPORATION

233 South Street • Hopkinton MA 01748 USA
Tel (800) 343-1001 • Fax (508) 655-8990

www.prediq.com

PRECISION
DIGITAL

The Complete **ProtEX™** Series

MAX



PD8-154
**4-Point Alarm
Annunciator**



PD8-6100
Strain Gauge Meter



PD8-158
**8-Point Alarm
Annunciator**



PD8-6200
**Analog Input
Flow Rate/Totalizer**



PD8-765
**Process &
Temperature Meter**



PD8-6210
**Analog Input Batch
Controller**



PD8-6000
Process Meter



PD8-6262
**Analog Dual-Input
Flow Rate/Totalizer**



PD8-6001
**Feet & Inches
Level Meter**



PD8-6300
**Pulse Input
Flow Rate/Totalizer**



PD8-6060
**Dual-Input
Process Meter**



PD8-6310
**Pulse Input
Batch Controller**



PD8-6080
**Modbus® Scanner
with Dual Analog Input**



PD8-6363
**Pulse Dual-Input
Flow Rate/Totalizer**



PD8-6081
**Feet & Inches
Modbus® Scanner**



PD8-7000
Temperature Meter

Go to PREDIG.COM for details on the entire ProtEX-MAX Series Meters

Disclaimer

The information contained in this document is subject to change without notice. Precision Digital makes no representations or warranties with respect to the contents hereof and specifically disclaims any implied warranties of merchantability or fitness for a particular purpose. See Warranty Information and Terms & Conditions on www.predig.com for complete details.

CAUTION

- Read complete instructions prior to installation and operation of the meter.

WARNINGS

- Risk of electric shock or personal injury.
- This product is not recommended for life support applications or applications where malfunctioning could result in personal injury or property loss. Anyone using this product for such applications does so at his/her own risk. Precision Digital Corporation shall not be held liable for damages resulting from such improper use.
- Failure to follow installation guidelines could result in death or serious injury. Make sure only qualified personnel perform the installation.
- Never remove the meter cover in explosive environments when the circuit is live.
- Cover must be fully engaged to meet explosion-proof/dust-ignition-proof/flame-proof requirements.

WARNING
Cancer and Reproductive Harm - www.P65Warnings.ca.gov

Limited Warranty

Precision Digital Corporation warrants this product against defects in material or workmanship for the specified period under “Specifications” from the date of shipment from the factory. Precision Digital’s liability under this limited warranty shall not exceed the purchase value, repair, or replacement of the defective unit. See Warranty Information and Terms & Conditions on www.predig.com for complete details.

Registered Trademarks

All trademarks mentioned in this document are the property of their respective owners.

© 2022 Precision Digital Corporation.
All rights reserved.

FREE MeterView Pro Programming Software



The meter can be powered from the USB connection. When using the USB connection, **DO NOT** apply AC or DC power to the meter.

The easiest and quickest way to program your ProtEX-MAX meter is to use the FREE MeterView Pro programming software. This software is loaded into the meter and connects and installs directly to your PC with a USB cable. We recommend that the first thing you do after taking the meter out of the box is connect the ProtEX-MAX to your PC with the provided USB cable – do not use a different cable. **DO NOT** apply AC or DC power to the meter while your PC is connected to the meter as it will disrupt the USB connection. You don’t even have to apply an input signal.

MeterView Pro programming software is intuitive, and most customers can get their meter programmed as they like without even looking in the manual.

Watch MeterView Pro Software Video at
www.predig.com/meterviewpro

In addition to programming, the software may be used for:

- Monitoring
- Datalogging using your PC
- Generating and saving programming files for later use

Once your meter is programmed the way you want it, you can wire it up for your application per the instructions in this manual and install it. If you find that you need to make adjustments to the programming after the meter is installed, you can use the front panel buttons and the instructions in this manual to do so.

WARNING

- When using the USB connection, the totalizer should only be connected to a computer when both devices are in a non-hazardous area.

Table of Contents

Introduction.....	7
Ordering Information.....	7
Key Features.....	9
Specifications	13
General.....	13
Dual Process Inputs.....	14
Dual Rate/Totalizer	15
Relays.....	16
USB Connection.....	16
Isolated 4-20 mA Transmitter Output Option.....	16
RS-485 Serial Communications	16
Modbus® RTU Serial Communications.....	16
Digital Input (F4).....	17
Digital Inputs & Outputs	17
MeterView Pro Software	17
Compliance Information.....	17
Electromagnetic Compatibility.....	17
Product Ratings and Approvals.....	18
EU Declaration of Conformity.....	19
Safety Information	19
Installation.....	19
Unpacking.....	19
Mounting.....	20
Installation Overview.....	22
MeterView Pro Software	22
Transmitter Supply Voltage Selection (P+, P-)	23
Connections	23
Required & Factory Wired Connection.....	23
PROVu Electronics Module Layout	24
USB Connection	24
Power Connections.....	25
Signal Connections.....	25
RS-485 Connections.....	26
RS-485 Multi-Drop Connection	26
Digital I/O Connections	27
F4 Digital Input Connections.....	27
Remote Programming.....	27
4-20 mA Output Connections.....	27
Analog Output Transmitter Power Supply.....	27
Relay Connections.....	28
Interlock Relay Feature.....	28
Switching Inductive Loads.....	28
Setup and Programming.....	29
Overview	29
LED Status Indicators.....	29
Programming Buttons	30
SafeTouch Buttons	30
Display Functions & Messages.....	31
Main Menu.....	34
Setting Numeric Values	34
Setting Up the Totalizer (SEtUP).....	35
Setting the Input Signal (InPUt).....	36
Setting the Totalizer Features (tOtAL).....	36
Setting the Rate, Total, & Grand Total Units/Tags (uNItS).....	36
Setting the Decimal Point (dEc Pnt)	37
Programming the Rate/Totalizer (PrGr).....	37
Setting the Display Parameters & Intensity (dSPLY).....	40
Display Intensity (d-IntY).....	40
Setting the Relay Operation (rELAY).....	41

- Relay and Alarm Operation Diagrams 43**
 - High Alarm Operation (Set > Reset) 43
 - Low Alarm Operation (Set < Reset) 43
 - High Alarm with Fail-Safe Operation (Set > Reset)..... 43
 - Low Alarm with Fail-Safe Operation (Set < Reset)..... 43
 - Time Delay Operation 44
 - Total Relay Sampling Operation 44
 - Pump Alternation Control Operation 45
 - Relay Sampling Operation 45
- Relay Operation Details 46**
 - Overview 46
 - Relays Auto Initialization 46
 - Fail-Safe Operation..... 46
 - Front Panel LEDs..... 46
 - Latching and Non-Latching Relay Operation 46
 - Non-Latching Relay (Rset) 47
 - Non-Latching Relay with Manual Reset (R-nRn)..... 47
 - Latching Relay (LRcH) 47
 - Latching Relay with Clear (Lc-Lr) 47
 - Acknowledging Relays 48
 - Pump Alternation Control Applications (RLtErn) 48
 - Setting Up the Interlock Relay (Force On) Feature 49
- Scaling the 4-20 mA Analog Output (Rout) 50**
- Reset Menu (rESEt)..... 50**
- Manual Control Menu (Control) 50**
- Setting Up the Password (PR55)..... 51**
 - Protecting or Locking the Totalizer Functions 51
 - Total Reset Password & Non-Resettable Total..... 51
 - Making Changes to a Password Protected Totalizer 51
 - Disabling Password Protection 51
- Advanced Features Menu 52**
 - Advanced Features Menu & Display Messages..... 52
 - Noise Filter (FiltEr) 54
 - Noise Filter Bypass (bYP55)..... 54
 - Rounding Feature (round)..... 54
 - Modbus RTU Serial Communications (SErRt)..... 54
 - Select Menu (SELEct)..... 55
 - Input Signal Conditioning (FunctiOn)..... 55
 - Square Root Linearization (SQRrE) 55
 - Programmable Exponent Linearization (PRoE E)..... 55
 - Multi-Point Linearization (LInER) 56
 - Math Function (nRtH)..... 56
 - Math Constants (ConSt)..... 56
 - Low-Flow Cutoff (LwFF)..... 56
 - Totalizer Count Up/Down (CounT)..... 57
 - Analog Output Programming (RoutPr) 58
 - Programmable Function Keys User Menu (uSEr)..... 59
 - Internal Calibration (IRL)..... 61
- Totalizer Operation..... 62**
 - Button Operation..... 62**
 - SafeTouch Buttons 62**
 - Function Keys Operation..... 63**
 - Digital Inputs Operation..... 63**
 - Maximum/Minimum Readings..... 63**
- Troubleshooting 64**
 - Diagnostics Menu (dRg) 64**
 - Testing the Display LEDs..... 64
 - Determining Software Version 64
 - Reset Totalizer to Factory Defaults 64**
 - Factory Defaults & User Settings 65
 - Troubleshooting Tips..... 67**

Table of Figures

Figure 1. Enclosure Dimensions – Front View.....	20
Figure 2. Enclosure Dimensions – Side Cross Section View	20
Figure 3. Transmitter Supply Voltage Selection	23
Figure 4. Integrated PROVu Required Connections	23
Figure 5. PROVu Electronics Module Layout	24
Figure 6. USB Connection	24
Figure 7. Power Connections	25
Figure 8. 2-Wire Transmitters Powered by Internal Supply	25
Figure 9. 3-Wire Transmitters Powered by Internal Supply	25
Figure 10. Transmitter Powered by External Supply	25
Figure 11. Self-Powered Transmitters	25
Figure 12. 2-Wire Voltage Input Connection	25
Figure 13. 3-Wire Voltage Input Connection	25
Figure 14. RS-485 Diagnostic LEDs	26
Figure 15. Three-Wire RS-485 Connection	26
Figure 16. Digital Input and Output Connections	27
Figure 17. F4 Digital Input Connections	27
Figure 18. 4-20 mA Output Connections	27
Figure 19. Analog Output Supply Powering Other Devices.....	27
Figure 20. Relay Connections	28
Figure 21. Interlock Connections	28
Figure 22. AC and DC Loads Protection.....	28
Figure 23. Low Voltage DC Loads Protection	28

Introduction

The ProtEX-MAX PD8-6262 is an explosion-proof dual-input rate/totalizer ideal for flow rate, total, and flow control applications. The totalizer features a dual-line display, with a main display 0.60" (15 mm) high, and a second display of 0.46" (12 mm) high superluminous LED digits, which can be read in any lighting condition, including direct sunlight. The totalizer is housed in a die-cast aluminum, field-mountable, NEMA 4X/IP68 rated enclosure for convenient indoor and outdoor installation.

The meter accepts two inputs; either can be current or voltage signals (e.g. 4-20 mA, 0-10 V) from analog output flowmeters. The rates, as measured by the flowmeters, are automatically aggregated into cumulative totals and grand totals which can be displayed with the rates.

Various math functions may be applied to the rate, total, and grand total of the two channels, including addition, difference, absolute difference, average, weighted average, multiplication, division, minimum, maximum, draw, ratio, and concentration. This is in addition to the input signal conditioning functions (linear, square root, programmable exponent, or round horizontal tank calculations).

The displays, relays, and the analog output may be assigned to the rate, total, or grand total of input channels A or B, or math result channel C. Three of the programming buttons can be set for custom operation.

A fully loaded ProtEX-MAX PD8-6262 dual-input rate/totalizer comes with four SPDT relays, a 4-20 mA output, two 24 VDC power supplies, five digital inputs and four digital outputs, and RS-485 serial communications. The four relays can be used for alarm indication or process control applications. The 4-20 mA isolated output, Modbus RTU serial communications, and digital I/O features make the ProtEX-MAX an excellent addition to any system.

Ordering Information

85-265 VAC Models

Model	Standard Features	Options Installed
PD8-6262-6H0	5 Digital Inputs, 4 Digital Outputs, RS-485 Communications	No options
PD8-6262-6H7		4 relays 4-20 mA output

12-24 VDC Models

Model	Standard Features	Options Installed
PD8-6262-7H0	5 Digital Inputs, 4 Digital Outputs, RS-485 Communications	No options
PD8-6262-7H7		4 relays 4-20 mA output

Accessories

Model	Description
PDA0001	3/4" M-NPT to F-M20 Reducer
PDA0002	3/4" M-NPT to 1/2" F-NPT Reducer
PDAPLUG75	3/4" Metal Conduit/Stopping Plug
PDA-SSTAG	Custom Stainless Steel Tag (see website for convenient ordering form)
PDA6848	2" U-Bolt Kit Zinc Plated Steel
PDA6848-SS	2" U-Bolt Kit Stainless Steel
PDA7485-I	RS-232 to RS-485 isolated converter
PDA8485-I	USB to RS-485 isolated converter

SafeTouch Buttons

To make it possible to program and operate the ProtEX-MAX in a hazardous area, the programming buttons that are located behind the glass window can be operated without removing the cover by using the SafeTouch through-glass buttons. The operator puts their finger on the glass over the button and the button is actuated.



To learn more about SafeTouch buttons, see this video:

predig.com/videos/Safetouch_Buttons

Helpful Videos

There are several videos that will help you get a better understanding of the features and functionality of the ProtEX-MAX products. Since the ProtEX-MAX meters have the same general features and functionality of the ProVu meters, appropriate videos for the ProVu meter are also included.

ProtEX-MAX Products Overview

Learn about the complete line of ProtEX-MAX products.



prediq.com/videos/ProtEXMAX_Overview

MeterView Pro Programming Software

Learn how easy it is to program the ProVu (ProtEX-MAX) process meter using MeterView Pro software.



prediq.com/videos/MVPro_SW

MeterView Pro Software Demonstration

Learn how easy it is to program Precision Digital's ProVu (ProtEX-MAX) process meter for a level application using MeterView Pro PC-based programming software.

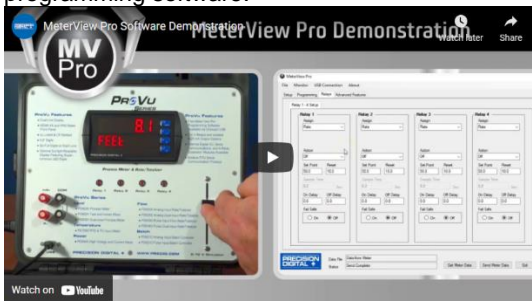

prediq.com/videos/MVPro_Demo

Connect to PC for Programming

Learn how to connect a ProVu (ProtEX-MAX) process meter to your PC and install free MeterView Pro programming software.



prediq.com/videos/PC_Connect

Key Features

FRONT

Mounting Flanges (Up to 2 1/2" Pipe)

Locking Screw

SafeTouch Menu Button

User Configurable Display Showing Math Function Result

User Configurable Display Showing Tag

Two 3/4" NPT Conduit Plugs

SafeTouch Right Arrow

SafeTouch Tare Display/Enter/Acknowledge

Explosion-Proof Die-Cast Aluminum NEMA 4X Enclosure

Large 0.6" Digits On Upper Display

Programmable Function Keys

Alarm Status Indicators

SafeTouch Reset Tare/Up Arrow

90° Rotatable Display

Sunlight Readable Display

NEMA 4X Enclosure

MeterView Pro
USB Installation

CONNECTIONS

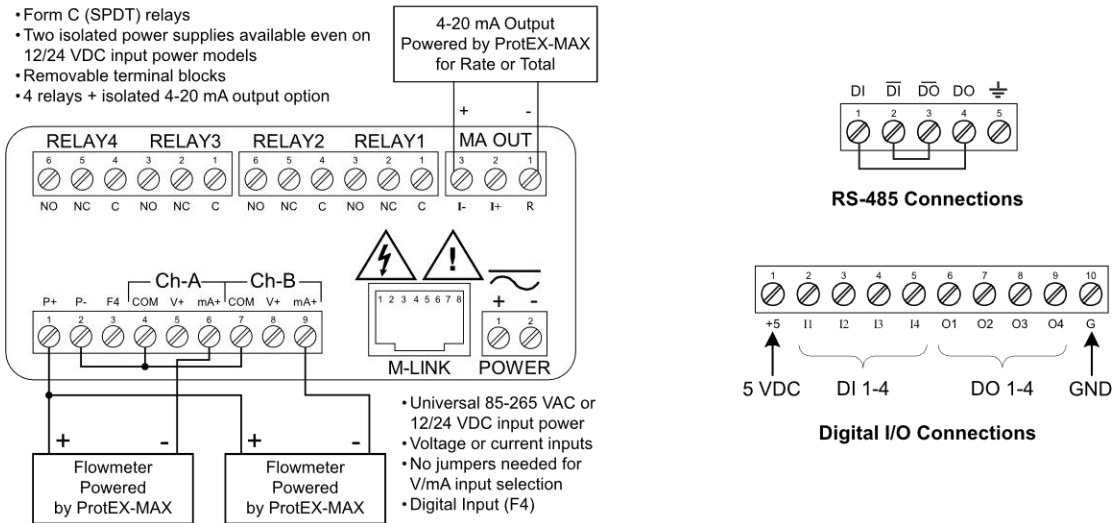

Connections for PD8-6262-6H7 & PD8-6262-7H7

Physical Features

The ProtEX-MAX is designed for ease-of-use in safe and hazardous applications. The ProtEX-MAX is housed in a rugged NEMA 4X explosion-proof enclosure, can operate over a wide temperature range, includes removable screw terminal connectors, has worldwide approvals for use in hazardous areas, and features through-glass buttons for easy controller operation without the need to remove the cover. All of these features are backed by a 3-year warranty.

Super-Bright LED Display

The ProtEX-MAX features a dual-line 6-digit display with super-bright LEDs, our brightest ever. These allow the display to be read in any lighting condition, even in direct sunlight.



SafeTouch Through-Glass Buttons

The ProtEX-MAX is equipped with four sensors that operate as through-glass buttons so that it can be programmed and operated without removing the cover (and exposing the electronics) in a hazardous area. These buttons can be disabled for security by selecting the DISABLE setting on the NO-CONTACT BUTTONS switch located on the back of the electronics module, inside the enclosure.

Rugged, Heavy-Duty Enclosure

The ProtEX-MAX is housed in a rugged NEMA 4X, 7, & 9, IP68 die-cast aluminum enclosure, designed to withstand harsh environments in safe and hazardous areas over a wide temperature range.



Wide Viewing Angle

Customers can't always look at the display from straight on, so the window and display module have been optimized to provide a wide viewing angle of approximately $\pm 40^\circ$; nearly twice that of the competition.



Built-In Mounting Flanges

The ProtEX-MAX is equipped with four slotted flanges for wall mounting or NPS 1½" to 2½" or DN 40 to 65 mm pipe mounting.



Flexible Mounting & Wiring

The ProtEX-MAX features four ¾" NPT threaded conduit openings so that wiring can be routed to the most convenient conduit connection(s). Two ¾" NPT metal conduit plugs with 12 mm hex key fitting come installed.



Rotatable Display

The ProtEX-MAX rotatable display, along with four available conduit connections, provide for numerous installation options. The display can be rotated in 90° increments. Rotate it 90° for horizontal mounting.



Vertical Mounting

Horizontal Mounting

Perfect & Secure Fit Every Time

The internal cast rails ensure the ProtEX-MAX assembles together perfectly, quickly and securely; and everything lines up for optimal viewing every time. There are no standoffs to worry about breaking or getting out of alignment. Two spring-loaded, self-retaining, thumbscrews make the assembly a snap, while pressing the display as close to the glass as possible to improve wide angle viewing.

Stainless Steel Tags

PDA-SSTAG is a laser etched stainless steel tag accessory for any of your Precision Digital meters. The tag features custom text for equipment identification, instruction, or whatever else is needed in your facility. Each tag comes with a stainless steel wire and lead seal for easy mounting wherever you need it.



Removable Screw Terminals

Industrial applications require screw terminal connections for easy field wiring, and the ProtEX-MAX goes one step further in convenience by also making them removable.



Note: The above photograph is representative of the back of the PD8-6262 in every regard except for the input signal connector. See Figure 5 on page 24 for actual input signal connections.

USB Port MeterView Pro

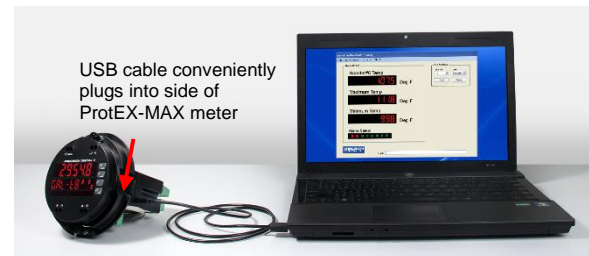

USB cable conveniently plugs into side of ProtEX-MAX meter

Hazardous Area Approvals

The ProtEX-MAX's approvals allow it to be used in hazardous areas around the world. These include: FM Approved as Explosion-Proof / Dust-Ignition-Proof / Flame-Proof, CSA Certified as Explosion-Proof / Dust-Ignition-Proof, and ATEX and IECEx Certified as Flame-Proof.

Wide Operating Temperature Range

The ProtEX-MAX can operate from -40 to 60°C (-40 to 140°F) meaning it can be installed in a wide variety of indoor and outdoor industrial applications. And over this range, the ProtEX-MAX will drift no more than 0.005% of calibrated span/°C max from 0 to 65°C ambient and 0.01% of calibrated span/°C max from -40 to 0°C ambient.

Useful Tools

PD9501 Multi-Function Calibrator



This [PD9501](#) Multi-Function Calibrator has a variety of signal measurement and output functions, including voltage, current, thermocouple, and RTD.

PD9502 Low-Cost Signal Generator



The [PD9502](#) is a low-cost, compact, simple to use 4-20 mA or 0-10 VDC signal generator. It can easily be set for 0-20 mA, 4-20 mA, 0-10 V or 2-10 V ranges. Signal adjustment is made with a one-turn knob. A 15-27 VDC wall plug is provided with the instrument. Optional USB power bank is available.

Specifications

Except where noted all specifications apply to operation at +25°C.

General

Display	Display Line 1: 0.60" (15 mm) high, red LEDs Display Line 2: 0.46" (12 mm) high, red LEDs 6 digits each (-99999 to 999999), with lead zero blanking
Display Intensity	Eight user selectable intensity levels. Default value is six.
Display Update Rate	5/second (200 ms)
LED Status Indicators	See <i>LED Status Indicators</i> on page 29 for details.
Overrange	Display flashes 999999
Underrange	Display flashes -99999
Display Assignment	Display lines 1 & 2 may be assigned to show: <ul style="list-style-type: none"> • One or more rate channels: Channel A (Ch-A), B (Ch-B), or C (Ch-C) • Toggle between rate channels: Ch-A & Ch-B, Ch-A & Ch-C, Ch-B & Ch-C, and Ch-A, Ch-B, & Ch-C • Total or grand total: Ch-A or Ch-B • Rate and total or grand total: Ch-A, Ch-B • Relay set points • Max/min values: Ch-A, Ch-B, or Ch-C • Toggle between any rate channel & units • Total and units: Ch-A or Ch-B • Toggle between totals: Ch-A & Ch-B; Ch-A, Ch-B, and sum of Ch-A and Ch-B • Modbus input Line 2 may also be set to show engineering units or be off, with no display.
Programming Methods	Four SafeTouch through-glass buttons when cover is installed. Mechanical buttons can be used with the cover removed. Free PC-based USB MeterView Pro programming software.
Noise Filter	Programmable from 2 to 199 (0 will disable filter)
Filter Bypass	Programmable from 0.1 to 99.9% of calibrated span
Recalibration	All ranges are calibrated at the factory. Recalibration is recommended at least every 12 months.
Max/Min Display	Max/min readings reached by the process are stored until reset by the user or until power to the totalizer is turned off.
Rounding	Select 1, 2, 5, 10, 20, 50, or 100 (e.g. rounding = 10, value = 123.45, display = 123.50).

Password	Three programmable passwords restrict modification of programmed settings and two prevent resetting the totals. Pass 1: Allows use of function keys and digital inputs Pass 2: Allows use of function keys, digital inputs and editing set/reset points Pass 3: Restricts all programming, function keys, and digital inputs. Total: Prevents resetting the total manually Gtotal: Prevents resetting the grand total manually
Non-Volatile Memory	All programmed settings are stored in non-volatile memory for a minimum of ten years if power is lost.
Power Options	85-265 VAC 50/60 Hz; 90-265 VDC, 20 W max; 12-24 VDC, 12-24 VAC, 15 W max. Powered over USB for configuration only.
Fuse	Required external fuse: UL Recognized, 5 A max, slow blow; up to 6 totalizers may share one 5 A fuse
Normal Mode Rejection	Greater than 60 dB at 50/60 Hz
Isolation	4 kV input/output-to-power line 500 V input-to-output or output-to-P+ supply
Overvoltage Category	Installation Overvoltage Category II: Local level with smaller transient overvoltages than Installation Overvoltage Category III.
Environmental	T6 Class operating temperature range Ta = -40 to 60°C T5 Class operating temperature range Ta = -40 to 65°C Storage temperature range: -40 to 85°C (-40 to 185°F) Relative humidity: 0 to 90% non-condensing
Max Power Dissipation	Maximum power dissipation limited to 15.1 W
Connections	Power, signal, relays, mA out: Removable screw terminal blocks accept 12 to 22 AWG wire. RS-485: Removable screw terminal block accepts 16 to 30 AWG wire. Digital I/O: Removable screw terminal blocks accept 16 to 30 AWG wire.
Enclosure	Explosion-proof die-cast aluminum with glass window, corrosion resistant epoxy coating, color: blue NEMA 4X, 7, & 9, IP68 Default conduit connections: Four 3/4" NPT threaded conduit openings and two 3/4" NPT metal conduit plugs with 12 mm hex key fitting installed. Additional conduit opening configurations may be available; verify quantity and sizes on specific device labeling during installation.

Mounting	<p>Wall Mounting: Four (4) mounting holes provided for mounting totalizer to wall. See <i>Wall Mounting Instructions</i> on page 20 for additional details.</p> <p>Pipe Mounting: Optional pipe mounting kit (PDA6848) allows for pipe mounting. Sold separately. See <i>Pipe Mounting Instructions</i> on page 21 for additional details.</p>
Tightening Torque	<p>Power, signal, relays, mA out terminals: 5 lb-in (0.56 Nm)</p> <p>Digital I/O and RS-485: 2.2 lb-in (0.25 Nm)</p>
Overall Dimensions	6.42" x 7.97" x 8.47" (W x H x D) (163 mm x 202 mm x 215 mm)
Weight	16.0 lbs (7.26 kg)
Warranty	3 years parts & labor. See Warranty Information and Terms & Conditions on www.prediq.com for complete details.

Dual Process Inputs

Two Inputs	Two non-isolated inputs, each separately field selectable: 0-20, 4-20 mA, ±10 V (0-5, 1-5, 0-10 V), Modbus PV (Slave)		
Isolated Transmitter Power Supply	Terminals P+ & P-: 24 VDC ± 10%. Isolated from the input at >500 V. Jumper selectable for 24, 10, or 5 VDC supply (internal jumper J4). All models transmitter supply rated @ 25 mA max. Refer to <i>Transmitter Supply Voltage Selection (P+, P-)</i> on page 23.		
Channels	Channel A, Channel B, Channel C (Math channel)		
Programmable Constants	Constant P (Adder): -99.999 to 999.999, default: 0.000 Constant F (Factor): 0.001 to 999.999, default: 1.000		
Math Functions	Name	Function	Setting
	Addition	$(A+B+P)*F$	5000
	Difference	$(A-B+P)*F$	d f
	Absolute diff.	$((Abs(A-B))+P)*F$	d f Rb5
	Average	$((A+B)/2)+P)*F$	Rb5
	Multiplication	$(A*B)+P)*F$	000000
	Division	$(A/B)+P)*F$	d f dE
	Max of A or B	$((AB-Hi)+P)*F$	H i - Rb
	Min of A or B	$((AB-Lo)+P)*F$	Lo - Rb
	Draw	$((A/B)-1)*F$	d r Rb
	Weighted avg.	$((B-A)*F)+A$	00 Rb5
	Ratio	$(A/B)*F$	r Rb 00
	Ratio 2	$((B-A)/A)+P)*F$	r Rb 002
	Concentration	$(A/(A+B))*F$	E 0nc E n
	Total Addition	$(tA+tB+P)*F$	5000 t
	G. Tot. Addition	$(GtA+GtB+P)*F$	5000Gt
	Total Difference	$(tA-tB+P)*F$	d f t Gt
	G. Tot. Difference	$(GtA-GtB+P)*F$	d f t Gt
	Total Ratio	$(tA/tB)*F$	t r Rb 00
	Total Ratio 2	$((tB-tA)/tA)*F$	t - r Rb 2
	Total Percent	$(tA/(tA+tB))*100$	t P E t

Note: The F constant can be any value from 0.001 to 999.999. If the value is less than 1, it will have the same effect as a divider. For example, the average could also be derived by using $(A+B)*F$, where $F = 0.500$.

Sequence of Operations for Input Programming	<ol style="list-style-type: none"> 1. Select Input for A and B 2. Set up the rate, total, and grand total engineering units for channels A & B, and units for math channel C 3. Set up rate, total, and grand total decimal points for channels A & B, and decimal point for math channel C 4. Program channel A & B rate parameters 5. Program channel A & B total and reset parameters 6. Set up display lines 1 and 2 7. Select the transfer function for A & B (e.g. Linear) 8. Select Math function for Channel C 9. Program constants for Factor (F) and Adder (P). 10. Program cutoff values for A and B 						
Accuracy	±0.03% of calibrated span ±1 count, square root & programmable exponent accuracy range: 10-100% of calibrated span						
Temperature Drift	0.005% of calibrated span/°C max from 0 to 65°C ambient, 0.01% of calibrated span/°C max from -40 to 0°C ambient						
Input Signal Conditioning	Linear, square root, or programmable exponent						
Multi-Point Linearization	2 to 32 points for channel A and B						
Programmable Exponent	User selectable from 1.0001 to 2.9999 for open channel flow						
Low-Flow Cutoff	0.1 to 999,999 (0 disables cutoff function). Point below at which the display always shows zero.						
Decimal Point	Up to five decimal places or none: <i>dddddd, dddddd, dddd, ddd, dd, or dddddd</i>						
Calibration Range	<table border="1"> <thead> <tr> <th>Input Range</th> <th>Minimum Span Input 1 & 2</th> </tr> </thead> <tbody> <tr> <td>4-20 mA</td> <td>0.15 mA</td> </tr> <tr> <td>±10 V</td> <td>0.10 V</td> </tr> </tbody> </table> <p>An error message will appear if the input 1 and input 2 signals are too close together.</p>	Input Range	Minimum Span Input 1 & 2	4-20 mA	0.15 mA	±10 V	0.10 V
Input Range	Minimum Span Input 1 & 2						
4-20 mA	0.15 mA						
±10 V	0.10 V						
Input Impedance	Voltage ranges: greater than 500 kΩ Current ranges: 50 - 100 Ω (depending on resettable fuse impedance)						
Input Overload	Current input protected by resettable fuse, 30 VDC max. Fuse resets automatically after fault is removed.						
HART Incompatible	The totalizer will interfere with HART signals when present on both analog inputs. It is recommended a single-channel totalizer be used to support the use of HART devices in both analog input loops.						

Dual Rate/Totalizer

Rate Display Indication	-99999 to 999999, lead zero blanking.
Total Display & Total Overflow	0 to 999,999; automatic lead zero blanking. Up to 999,999,999 with total-overflow feature. "oF" is displayed to the left of total overflow and ▲ LED is illuminated.
Total Decimal Points	Up to five decimal places or none: <i>dddddd, dddddd, dddd, ddd, dd, or dddddd</i> Total decimal point is independent of rate decimal point. Channel A and B decimal points programmed independently.
Dual Totalizer	Calculates total for channels A and B based on rate and field programmable multiplier to display total in engineering units. Time base must be selected according to the time units in which the rate is displayed. Channel A and B totalizer parameters programmed independently.
Totalizer Rollover	Totalizer rolls over when display exceeds 999,999,999. Relay status reflects display.
Total Overflow Override	Program total A or B total reset for automatic with 0.1 second delay and set point 1 for 999,999
Totalizer Presets	Four, user selectable under setup menu. Any set point can be assigned to channel A or B total or grand total (or C) and may be programmed anywhere in the range of the totalizer for total alarm indication.
Total Reset Password	Total and grand total passwords may be entered to prevent resetting the totals or grand totals from the front panel.
Total & Grand Total Reset	Via front panel button, external contact closure on digital inputs, automatically via user selectable preset value and time delay, or through serial communications. Channel A and B total and grand total reset parameters programmed independently.
Programmable Delay On Release	0.1 and 999.9 seconds; applied to the first relay assigned to total or grand total. If the totalizer is programmed to reset total to zero automatically when the preset is reached, then a delay will occur before the total is reset.
Non-Resettable Total	The grand totals can be programmed as non-resettable totals by entering the password "050873". Both channels are set to non-resettable when this password is entered.
Non-Volatile Memory	Total and Grand Total values are stored in non-volatile memory for a minimum of ten years if power is lost.

⚠ CAUTION

- Once the Grand Total has been programmed as "non-resettable" the feature **CANNOT** be disabled.

Relays

Rating	4 SPDT (Form C) internal and rated 3 A @ 30 VDC and 125/250 VAC resistive load; 1/14 HP (\approx 50 W) @ 125/250 VAC for inductive loads
Noise Suppression	Noise suppression is recommended for each relay contact switching inductive loads; see <i>Switching Inductive Loads</i> page on page 28 for details.
Relay Assignment	Relays may be assigned to channel A or B rate, total, or grand total; channel C; or Modbus control.
Deadband	0-100% of span, user programmable
High or Low Alarm	User may program any alarm for high or low trip point. Unused alarm LEDs and relays may be disabled (turn off).
Relay Operation	<ul style="list-style-type: none"> Automatic (non-latching) and/or manual reset Latching (requires manual acknowledge) with or without clear Pump alternation control (2-4 relays) Sampling (based on set point and time) Off (disable unused relays and enable Interlock feature) Manual on/off control mode
Relay Reset (Acknowledge)	User selectable via front panel button, F4 digital input, external contact closure on digital inputs, or through serial communications. <ol style="list-style-type: none"> Automatic reset only (non-latching), when the input passes the reset point. Automatic + manual reset at any time (non-latching) Manual reset only, at any time (latching) Manual reset only after alarm condition has cleared (L) <p>Note: Front panel button, F4 terminal at back of totalizer or digital input may be assigned to acknowledge relays programmed for manual reset.</p>
Time Delay	0 to 999.9 seconds, on & off relay time delays. Programmable and independent for each relay
Fail-Safe Operation	Programmable and independent for each relay. <p>Note: Relay coil is energized in non-alarm condition. In case of power failure, relay will go to alarm state.</p>
Auto Initialization	When power is applied to the totalizer, relays will reflect the state of the input to the totalizer.

USB Connection

Function	Programming only
Compatibility	USB 2.0 Standard, Compliant
Connector Type	Micro-B receptacle
Cable	USB A Male to Micro-B Cable
Driver	Microsoft® Windows® XP/Vista/7/8/10
Power	USB port provides power to the totalizer. DO NOT apply AC or DC power to the totalizer while the USB port is in use.

Isolated 4-20 mA Transmitter Output Option

Output Source	Input channels A or B, rate, total, or grand total; channel C; max or min for channel A or B; highest or lowest max or min of A and B; set points 1-4; Modbus input; or manual control mode									
Scaling Range	1.000 to 23.000 mA for any display range									
Calibration	Factory calibrated: 4.000 to 20.000 = 4-20 mA output									
Analog Out Programming	23.000 mA maximum for all parameters: Overrange, underrange, max, min, and break									
Accuracy	\pm 0.1% of span \pm 0.004 mA									
Temperature Drift	0.4 μ A/ $^{\circ}$ C max from 0 to 65 $^{\circ}$ C ambient, 0.8 μ A/ $^{\circ}$ C max from -40 to 0 $^{\circ}$ C ambient Note: Analog output drift is separate from input drift.									
Isolated Transmitter Power Supply	Terminals I+ & R: 24 VDC \pm 10%. Used to power the 4-20 mA output. All models rated @ 25 mA max.									
External Loop Power Supply	35 VDC maximum									
Output Loop Resistance	<table border="1"> <thead> <tr> <th>Power supply</th> <th>Minimum</th> <th>Maximum</th> </tr> </thead> <tbody> <tr> <td>24 VDC</td> <td>10 Ω</td> <td>700 Ω</td> </tr> <tr> <td>35 VDC (external)</td> <td>100 Ω</td> <td>1200 Ω</td> </tr> </tbody> </table>	Power supply	Minimum	Maximum	24 VDC	10 Ω	700 Ω	35 VDC (external)	100 Ω	1200 Ω
Power supply	Minimum	Maximum								
24 VDC	10 Ω	700 Ω								
35 VDC (external)	100 Ω	1200 Ω								

RS-485 Serial Communications

Compatibility	EIA-485
Connectors	Removable screw terminal connector
Max Distance	3,937' (1,200 m) max
Status Indication	Status Indication / Separate LEDs for Power (METER LINK), Transmit (TX), and Receive (RX)

Modbus® RTU Serial Communications

Slave Id	1 – 247 (Meter address)
Baud Rate	300 – 19,200 bps
Transmit Time Delay	Programmable between 0 and 199 ms
Data	8 bit (1 start bit, 1 or 2 stop bits)
Parity	Even, Odd, or None with 1 or 2 stop bits
Byte-To-Byte Timeout	0.01 – 2.54 second
Turn Around Delay	Less than 2 ms (fixed)
Note:	Refer to the ProtEX-MAX Modbus Register Tables located at www.prediq.com for details.

Digital Input (F4)

Function	Remote operation of front-panel buttons, acknowledge/reset relays, reset totals, reset max/min values. See <i>Function Keys & Digital I/O Available Settings</i> on page 60 for a complete list of capabilities.
Contacts	3.3 VDC on contact. Connect normally open contacts across F4 to COM
Logic Levels	Logic High: 3 to 5 VDC Logic Low: 0 to 1.25 VDC

Digital Inputs & Outputs

Function	Terminals provided for remote operation of all four programming / operation buttons. Other uses include acknowledge/reset relays, reset totals, and reset max/min values. See <i>Function Keys & Digital I/O Available Settings</i> on page 60 for a complete list of capabilities.
Channels	4 digital inputs & 4 digital outputs
Digital Input Logic High	3 to 5 VDC
Digital Input Logic Low	0 to 1.25 VDC
Digital Output Logic High	3.1 to 3.3 VDC
Digital Output Logic Low	0 to 0.4 VDC
Source Current	10 mA maximum output current
Sink Current	1.5 mA minimum input current
+5 V Terminal	To be used as pull-up for digital inputs only. Connect normally open push buttons across +5 V & DI 1-4.

WARNING

- **DO NOT** use +5 V terminal to power external devices.

MeterView Pro Software

Availability	Download directly from totalizer or from www.prediq.com/download_software
System Requirements	Microsoft® Windows® XP/Vista/7/8/10
Communications	USB 2.0 (for programming only) (USB A Male to Micro-B Cable) RS-485 to USB converter (programming, monitoring, and data logging)
Configuration	Configure totalizers one at a time
Power	USB port provides power to the totalizer. DO NOT apply AC or DC power to the totalizer while the USB port is in use.

Compliance Information

Electromagnetic Compatibility

Emissions	EN 55022 Class A ITE emissions requirements
Radiated Emissions	Class A
AC Mains Conducted Emissions	Class A
Immunity	EN 61326-1 Measurement, control, and laboratory equipment EN 61000-6-2 EMC heavy industrial generic immunity standard
RFI - Amplitude Modulated	80 -1000 MHz 10 V/m 80% AM (1 kHz) 1.4 - 2.0 GHz 3 V/m 80% AM (1 kHz) 2.0 - 2.7 GHz 1 V/m 80% AM (1 kHz)
Electrical Fast Transients	±2kV AC mains, ±1kV other
Electrostatic Discharge	±4kV contact, ±8kV air
RFI - Conducted	10V, 0.15-80 MHz, 1kHz 80% AM
AC Surge	±2kV Common, ±1kV Differential
Surge	1KV (CM)
Power-Frequency Magnetic Field	30 A/m 70%V for 0.5 period
Voltage Dips	40%V for 5 & 50 periods 70%V for 25 periods
Voltage Interruptions	<5%V for 250 periods

Note: Testing was conducted on meters with cable shields grounded at the point of entry representing installations designed to optimize EMC performance.

Product Ratings and Approvals

FM	Enclosure: Type 4X; IP66 Class I, Division 1, Groups B, C, D Class II, Division 1, Groups E, F, G Class III, Division 1, T5/T6 Class I, Zone 1, AEx d, IIC Gb T5/T6 Zone 21, AEx tb IIIC T90°C; Ta = -40°C to +65°C T6 Ta = -40°C to +60°C; T5 Ta = -40°C to +65°C Certificate Number: 3047283
CSA	Class I, Division 1, Groups B, C, D Class II, Division 1, Groups E, F, G Class III, Division 1 Class I Zone 1 Ex d IIC Zone 21 Ex tb IIIC T90°C -40°C < Tamb. < +60° C; Temperature Code T6 -40°C < Tamb. < +65° C; Temperature Code T5 Enclosure Type 4X & IP68 Certificate Number: 2531731
ATEX 	II 2 G D Ex d IIC T* Gb Ex tb IIIC T90°C Db IP68 Ta = -40°C to +°C *T6 = -40°C to +60°C *T5 = -40°C to +65°C Certificate number: Sira 12ATEX1182
IECEx	Ex d IIC T* Gb Ex tb IIIC T90°C Db IP68 Ta = -40°C to +°C *T6 = -40°C to +60°C *T5 = -40°C to +65°C Certificate Number: IECEx SIR 12.0073

Special Conditions for Safe Use:

Use suitably certified and dimensioned cable entry device and/or plug. The equipment shall be installed such that the supply cable is protected from mechanical damage. The cable shall not be subjected to tension or torque. If the cable is to be terminated within an explosive atmosphere, then appropriate protection of the free end of the cable shall be provided. Cable must be suitable for 90°C.

Year of Construction

This information is contained within the serial number with the first four digits representing the year and month in the YYMM format.

For European Community: The ProtEX-MAX must be installed in accordance with the ATEX directive 94/9/EC, and the product certificate Sira 12ATEX1182.

EU Declaration of Conformity

EU Declaration of Conformity is available in the Documentation CD provided with the product under the EU DoC menu.

Safety Information

⚠ CAUTION

- Read complete instructions prior to installation and operation of the totalizer.

⚠ WARNINGS

- Risk of electric shock or personal injury.
- Hazardous voltages exist within enclosure. Installation and service should be performed only by trained service personnel.

Installation

Install in accordance with applicable local and national regulations (e.g. NEC).

For Installation in USA

The ProtEX-MAX must be installed in accordance with the National Electrical Code (NEC) NFPA 70.

For Installation in Canada

The ProtEX-MAX must be installed in accordance with the Canadian Electrical Code CSA 22.1. All power supplies below 36 V and input circuits must be derived from a CSA Approved Class 2 source.

For European Community

The ProtEX-MAX must be installed in accordance with the ATEX directive 94/9/EC and the product certificate Sira 12ATEX1182.

⚠ WARNINGS

- Disconnect from supply before opening enclosure.
- Keep cover tight while circuits are live.
- Conduit seals must be installed within 18" (450mm) of the enclosure or within 2" (50mm) for Zone installations.

Wiring connectors are accessed by opening the enclosure. To access electrical connectors, remove the 2 captive screws and then remove the electronics module. Connectors are on the rear of the electronics module.

Unpacking

Remove the totalizer from box. Inspect the packaging and contents for damage. Report damages, if any, to the carrier.

If any part is missing or the totalizer malfunctions, please contact your supplier or the factory for assistance.

Pre-Installed Conduit Plugs

The ProtEX-MAX is supplied with two pre-installed conduit plugs for installations that do not require the use of all four conduit entries. The conduit/stopping plugs include an internal hexagonal socket recess for removal. The conduit plugs and their factory installation are included in all hazardous area approvals of this product.

⚠ WARNING

- In hazardous areas, conduit and conduit/stopping plugs require the application of non-setting (solvent free) thread sealant. It is critical that all relevant hazardous area guidelines be followed for the installation or replacement of conduit or plugs.

Cover Jam Screw



The cover jam screw should be properly installed once the totalizer has been wired and tested in a safe environment. The cover jam screw is intended to prevent the removal of the totalizer cover in a hazardous environment without the use of tools. Using a M2 hex wrench, turn the screw clockwise until the screw contacts the totalizer. Turn the screw an additional 1/4 to 1/2 turn to secure the cover.

⚠ CAUTION

- Excess torque may damage the threads, screw head, and wrench.

Mounting

The ProtEX-MAX has four slotted mounting flanges that may be used for pipe mounting or wall mounting. Refer to *Figure 1* and *Figure 2* below.

WARNING

- Do not attempt to loosen or remove flange bolts while the totalizer is in service.

Mounting Dimensions

All units: inches (mm)

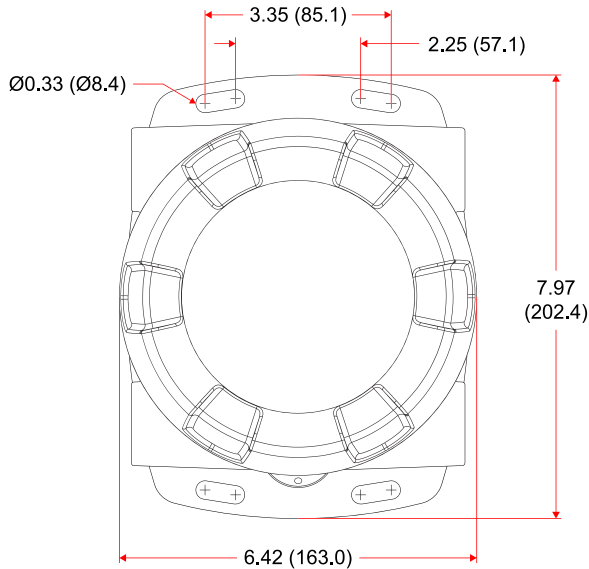

Figure 1. Enclosure Dimensions – Front View

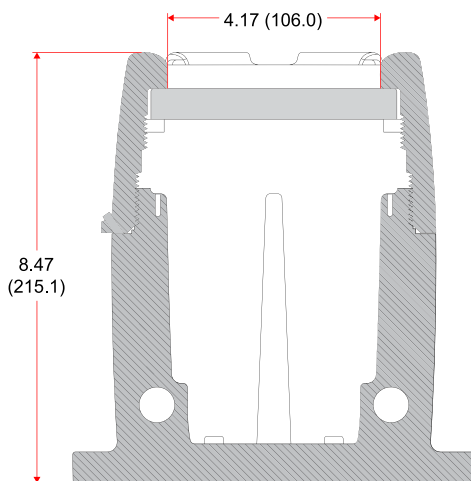

Figure 2. Enclosure Dimensions – Side Cross Section View

Wall Mounting Instructions

The totalizer can be mounted to any wall or flat surface using the four provided mounting holes located in the cast-in flanges. In addition, the internal electronic assembly can be rotated to allow the enclosure to be mounted in any position. To mount the totalizer to a wall, follow these instructions:

- Prepare a section of wall approximately 7" x 8.5" (178 mm x 216 mm) for totalizer mounting by marking with a pencil the mounting holes (shown in *Figure 1*) on the wall.
- Select the appropriate mounting screws for the mounting surface to be used. The mounting holes diameter is shown on *Figure 1*.

Note: Mounting screws are not included.

- Using a drill bit slightly smaller than the girth of the mounting screws, pre-drill holes at the mounting locations previously marked.
- Insert mounting screws into the four mounting holes and screw them into the pre-drilled holes.



Download free 3-D CAD files of these instruments to simplify your drawings!

predig.com/documentation-cad

Pipe Mounting Instructions



Vertical Pipe Mounting

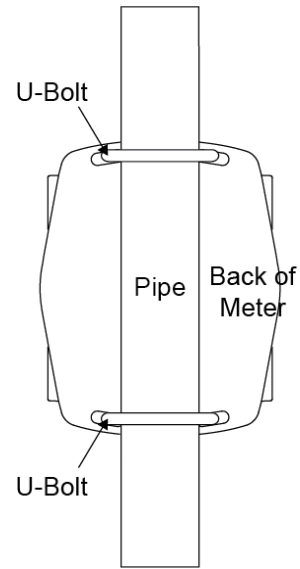

The totalizer can also be mounted to a pipe using an optional U-Bolt kit. This kit includes two U-bolts, the necessary hardware, and is available in zinc plated steel ([PDA6848](#)) and 316 stainless steel ([PDA6848-SS](#)).

Horizontal Pipe Mounting

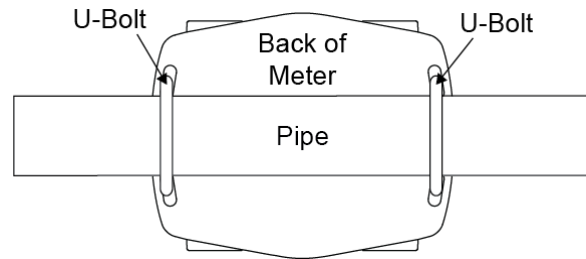

To mount the totalizer using a U-Bolt kit, follow these instructions:

- Orient the groove on the back of the instrument with the pipe and secure it to the pipe with the two U-bolts and hardware provided.



Installation Overview

We recommend the following sequence for getting the totalizer into service:

1. **DO NOT** apply AC or DC power to the totalizer.
2. Connect the totalizer to the PC with the USB cable provided. **DO NOT** use a different USB cable.
3. If MeterView Pro (MVPro) is already installed in your computer, then the program will launch automatically in most systems. If the program does not start automatically, double-click on the MVPro icon.
4. If MVPro is not installed, follow the instructions provided below.
5. Use MVPro to configure the totalizer for your application.
6. Disconnect the USB cable from the totalizer.
7. Apply power and signal and check operation of the totalizer.
8. Install the totalizer and put into service.
9. Make any programming adjustments using the front panel buttons.

MeterView Pro Software

The easiest and quickest way to program your ProtEX-MAX totalizer is to use the FREE MeterView Pro programming software. This software is loaded into the totalizer and connects and installs directly to your PC with the USB cable provided. **DO NOT** use a different USB cable. We recommend that the first thing you do after taking the totalizer out of the box is connect the ProtEX-MAX to your PC with the provided USB cable. **DO NOT** apply AC or DC power to the totalizer while your PC is connected to the totalizer as it will disrupt the USB connection. It is not necessary to apply an input signal.

MeterView Pro programming software is intuitive, and most customers can get their totalizer programmed as they like without even looking in the manual.

Watch MeterView Pro Software Video at www.prediq.com/meterviewpro

MeterView Pro Installation

1. Connect one end of the provided USB cable to the totalizer and the other end to the computer. The computer will automatically install the driver software it needs to talk to the totalizer. Follow the on-screen instructions and allow sufficient time for the process to complete. This can take a few minutes. If the process is interrupted, then it could leave the system in an unstable condition.

⚠️ WARNINGS

- Only one totalizer may be connected at a time. Attaching multiple totalizers will cause a conflict with the totalizer software.
- **DO NOT** apply AC or DC power to the totalizer when using the USB connection.
- When using the USB connection, the totalizer should only be connected to a computer when both devices are in a non-hazardous area.

2. Once the driver is installed, an AutoPlay dialog should appear for the drive "MAINSTAL." Click "Open folder to view files."

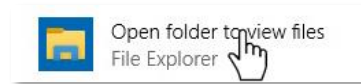

If the computer does not display an AutoPlay dialog for the drive "MAINSTAL," you should open My Computer and double-click on the drive labeled "MAINSTAL."

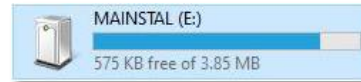

3. Double-click on the file named "MAStart." The program will open a few windows and install two programs on your computer. Simply follow the on-screen instructions until you see one of the dialogs below. If you receive a "User Account Control" warning, click "Yes."

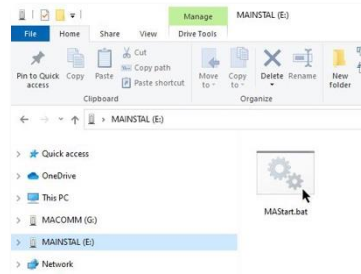

4. If there is an update available, click the "Update" button to install the new version. Otherwise, click "Configure" to begin programming your totalizer.

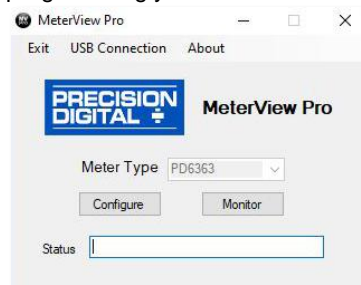

Note: If you decide to update your MeterView Pro software, once the installation has completed, you will be asked if you want to update the setup files located on the totalizer itself. This way, you will always have the most current version on the totalizer for future installs.

⚠️ WARNING

- **DO NOT** unplug the totalizer while the new installation files are being written to it. The totalizer will display ۛۛۛ during the process and you will receive an on-screen notification once the process is complete.

Transmitter Supply Voltage Selection (P+, P-)

All totalizers, including models equipped with the 12-24 VDC power option, are shipped from the factory configured to provide 24 VDC power for the transmitter or sensor.

If the transmitter requires 5 or 10 VDC excitation, the internal jumper J4 must be configured accordingly.

To access the voltage selection jumper:

1. Remove all the wiring connectors.
2. Unscrew the back cover.
3. Slide out the back cover by about 1 inch.
4. Configure the J4 jumper, located behind the input signal connector, for the desired excitation voltage as shown.

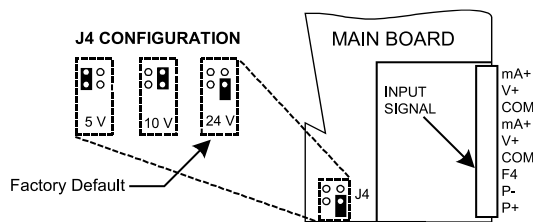

Figure 3. Transmitter Supply Voltage Selection

Connections

All connections are made to removable screw terminal connectors located at the rear of the totalizer.

CAUTION

- Use copper wire with 60°C or 60/75°C insulation for all line voltage connections. Observe all safety regulations. Electrical wiring should be performed in accordance with all applicable national, state, and local codes to prevent damage to the totalizer and ensure personnel safety.

WARNINGS

- Observe all safety regulations. Electrical wiring should be performed in accordance with all agency requirements and applicable national, state, and local codes to prevent damage to the totalizer and ensure personnel safety.
- Static electricity can damage sensitive components.
- Observe safe handling precautions for static-sensitive components.
- Use proper grounding procedures/codes.
- If the instrument is installed in a high voltage environment and a fault or installation error occurs, high voltage may be present on any lead or terminal.
- Follow all fusing and wiring precautions requirements for the instrument integrated to the PD8 Series model number being connected.

To access the connectors, remove the enclosure cover and unscrew the two captive screws that fasten the electronics module. Signal connections are made to de-pluggable connectors on the back of the electronics module.

Some connectors may be provided already connected. These connections are required for proper operation of the ProtEX-MAX, and should not be removed unless instructed to by this manual.

Wires marked as being used for testing purposes should be removed.

Grounding connections are made to the two ground screws provided on the base – one internal and one external.

After all connections have been completed and verified, apply power to the unit.

Required & Factory Wired Connection

The ProtEX-MAX comes with a pre-wired connection. This connection is detailed below and must be maintained in order for the instrument to function properly.

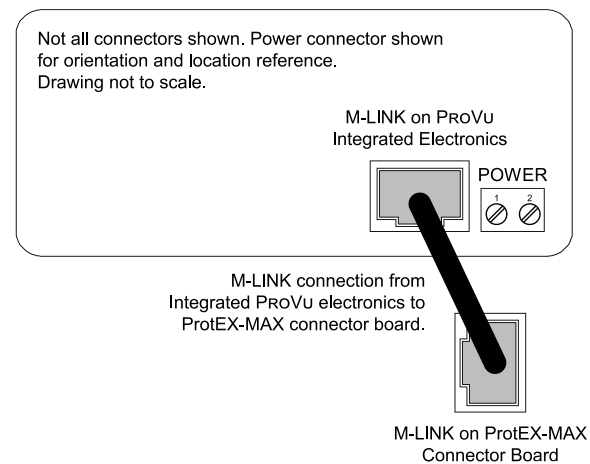
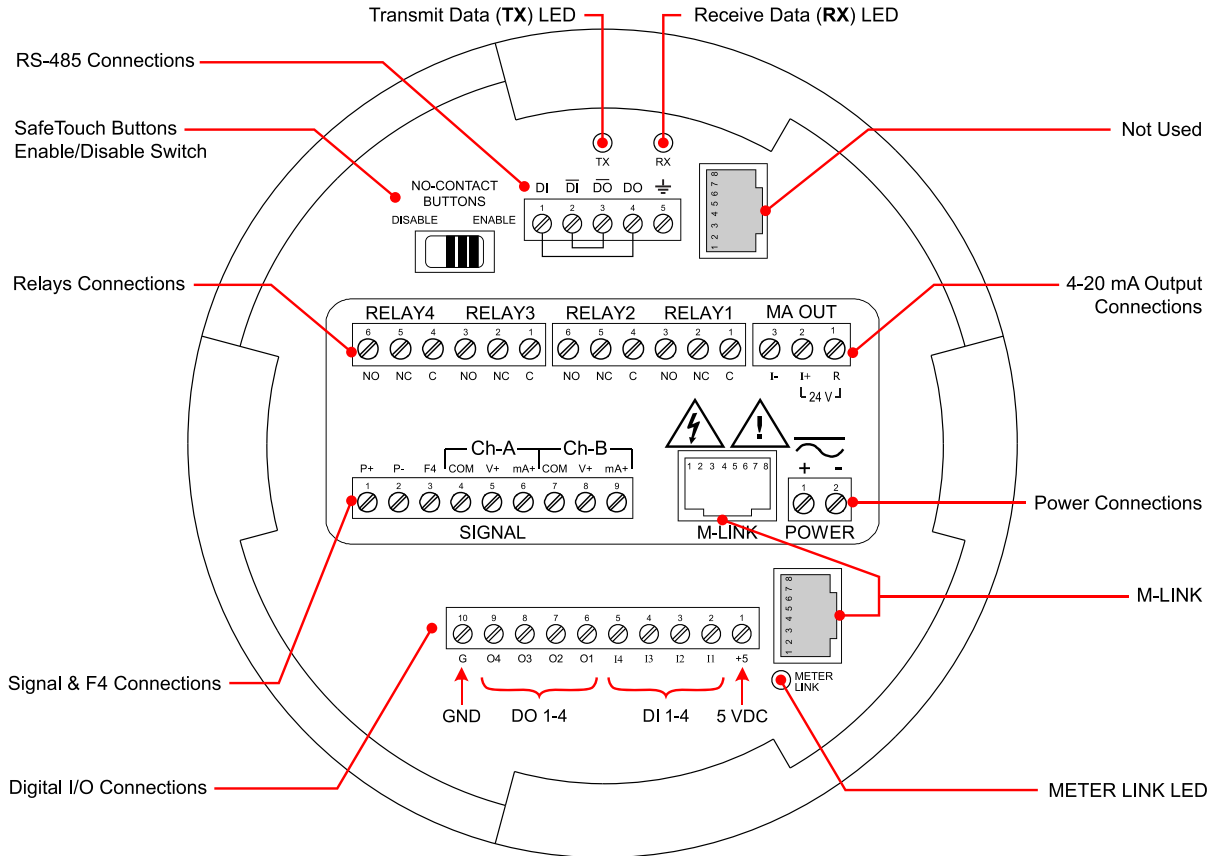

Figure 4. Integrated ProVu Required Connections

ProVu Electronics Module Layout for PD8-6262-6H7 and PD8-6262-7H7*



* For models PD8-6262-6H0 and PD8-6262-7H0, the upper set of connectors (RELAYs & MA OUT) are not present
Figure 5. ProVu Electronics Module Layout

USB Connection

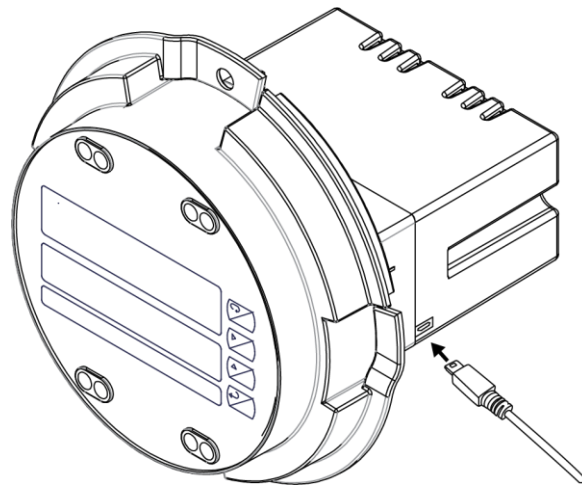

Figure 6. USB Connection

⚠ WARNINGS

- **DO NOT** disconnect the RJ45 M-LINK connector cable. Otherwise the instrument will not function properly.
- When using the USB connection, the totalizer should only be connected to a computer when both devices are in a non-hazardous area.

Power Connections

Power connections are made to a two-terminal connector labeled POWER. The totalizer will operate regardless of DC polarity connection. The + and - symbols are only a suggested wiring convention. There are separate models for low voltage and high voltage power. See *Ordering Information* on page 7 for details.

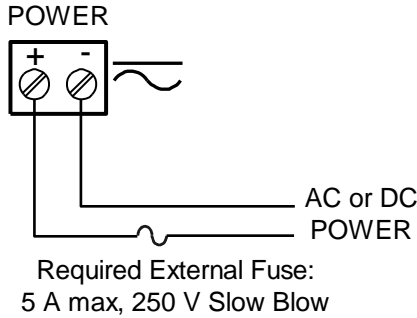

Figure 7. Power Connections

Signal Connections

Signal connections are made to a nine-terminal connector labeled SIGNAL. The COM (common) terminals are the return for the 4-20 mA and the ± 10 V input signals. The two COM terminals connect to the same common return, and are not isolated. There are no switches or jumpers to set up for current and voltage inputs. Setup and programming is performed through the programming buttons or MeterView Pro software.

Current (mA) Connections

The following figures show examples of current connections.

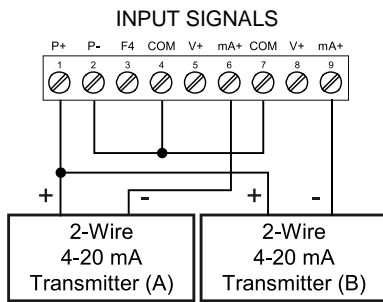

Figure 8. 2-Wire Transmitters Powered by Internal Supply

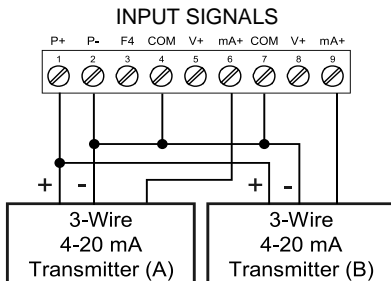

Figure 9. 3-Wire Transmitters Powered by Internal Supply

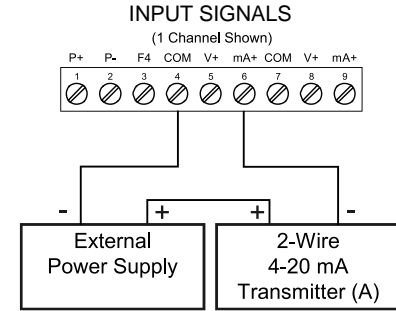

Figure 10. Transmitter Powered by External Supply

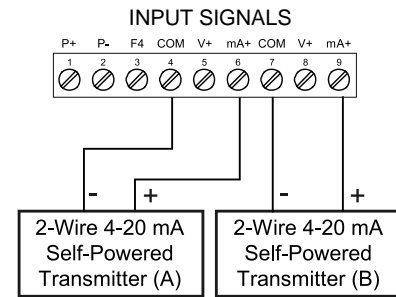

Figure 11. Self-Powered Transmitters

The current input is protected against current overload by a resettable fuse. The display may or may not show a fault condition depending on the nature of the overload.

The fuse limits the current to a safe level when it detects a fault condition, and automatically resets itself when the fault condition is removed.

Voltage Connections

The following figures show examples of voltage connections.

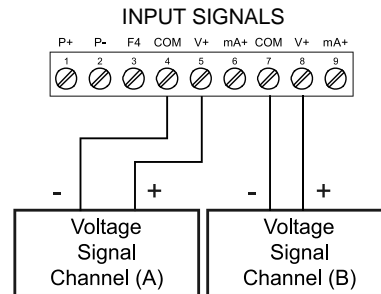

Figure 12. 2-Wire Voltage Input Connection

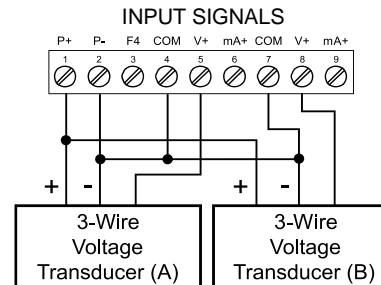

Figure 13. 3-Wire Voltage Input Connection

The meter is capable of accepting any voltage from -10 VDC to +10 VDC.

RS-485 Connections



The RS-485 connections are made to a five terminal connector used for Modbus® RTU serial communications. The RS-485 terminals include Transmit Data (DO) and (/DO), Receive Data (DI) and (/DI), and Signal Ground. See *Modbus RTU Serial Communications (Serial)* on page 54 for more information.

There are three diagnostic LEDs: Transmit Data (TX), Receive Data (RX) and METER LINK to show when the totalizer is transmitting and receiving data from other devices.

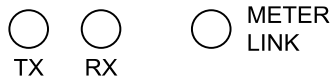

Figure 14. RS-485 Diagnostic LEDs

RS-485 Multi-Drop Connection

When using more than one totalizer in a multi-drop mode, each totalizer must be provided with its own unique address. The meter address (Slave ID) can be programmed between 1 and 247. The transmit delay can be set between 0 and 199 ms. The parity can be set to even, odd, or none with 1 or 2 stop bits.

To change the meter address:

1. Press and hold the Menu button for three seconds to access Advanced Features menu of the totalizer.
2. Press Up arrow until Serial (Serial) menu is displayed and press Enter, Addr E5 is displayed.
3. Press Enter to change meter address using Right and Up arrow buttons. Press Enter to accept.
4. Press Menu button to exit and return to Run Mode.

Three-Wire Connection

In order to wire the five pins for use as a three-wire half-duplex RS-485 connection, it is necessary to create a jumper connection between DI to DO and /DI to /DO- as shown below.

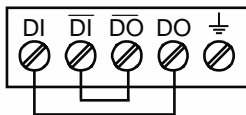

Figure 15. Three-Wire RS-485 Connection

Digital I/O Connections



Digital inputs and outputs are provided in order to expand the functionality of the totalizer. Digital input connections are made via a push button or switch to the appropriate digital input terminal and the +5 VDC terminal. Digital output connections are made by wiring from the appropriate digital output terminal to the ground terminal.

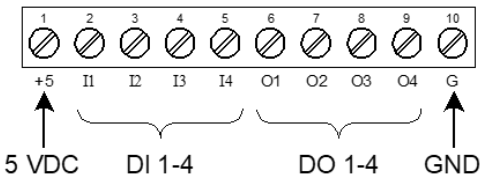

Figure 16. Digital Input and Output Connections

IMPORTANT

The onboard digital inputs (1-4) are configured at the factory to function identically to the front panel pushbuttons (Menu, F1, F2, & F3) in order to work with the SafeTouch buttons. Changing the programming of the digital inputs will affect the function of the SafeTouch buttons. If you wish to change the behavior of the digital inputs, re-assign F1-F3 to the desired function, then change the corresponding digital input to match.

WARNING

- **DO NOT** disconnect the RJ45 M-LINK connector cable. Otherwise the instrument will not function properly.

F4 Digital Input Connections

A digital input, F4, is standard on the totalizer. This digital input connected with a normally open closure across F4 and COM, or with an active low signal applied to F4. It can be used for remote operation of front-panel buttons, to acknowledge/reset relays, reset totals, or to reset max/min values. See *Function Keys & Digital I/O Available Settings* on page 60 for a complete list of capabilities.

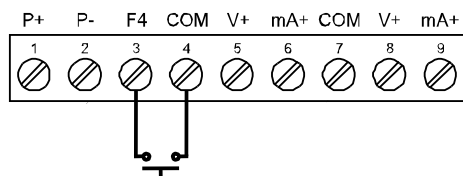

Figure 17. F4 Digital Input Connections

Remote Programming

The totalizer can be operated via the programming buttons or a remote control station with required approvals to be located in a hazardous area using the digital inputs and outputs.

4-20 mA Output Connections

Connections for the 4-20 mA transmitter output are made to the connector terminals labeled MA OUT. The 4-20 mA output may be powered internally or from an external power supply.

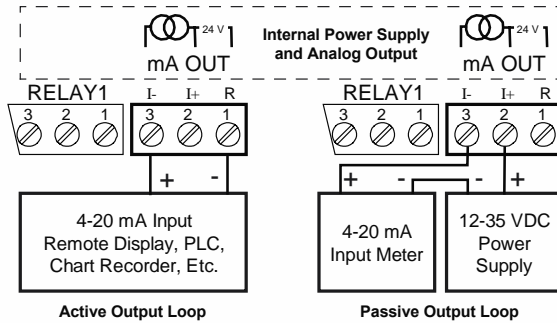

Figure 18. 4-20 mA Output Connections

Analog Output Transmitter Power Supply

The internal 24 VDC power supply powering the analog output may be used to power other devices, if the analog output is not used. The I+ terminal is the +24 V and the R terminal is the return.

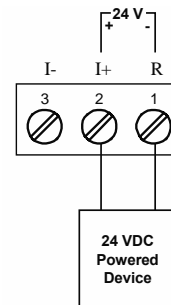

Figure 19. Analog Output Supply Powering Other Devices

Relay Connections

Relay connections are made to two six-terminal connectors labeled RELAY1 – RELAY4. Each relay's C terminal is common only to the normally open (NO) and normally closed (NC) contacts of the corresponding relay. The relays' C terminals should not be confused with the COM (common) terminal of the INPUT SIGNAL connector.

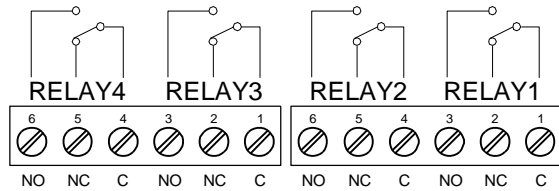

Figure 20. Relay Connections

Interlock Relay Feature

As the name implies, the interlock relay feature reassigns one, or more, alarm/control relays for use as interlock relay(s). Interlock contact(s) are wired to digital input(s) and activate the interlock relay. This feature is enabled by configuring the relay, and the corresponding digital input(s), see *Setting Up the Interlock Relay (Force On) Feature* on page 49.

In the example below, an Interlock Contact switch is connected to a digital input, which will be used to force on (energize) the Interlock Relay. The Interlock Relay and the Control Relay are connected in series with the load.

- When the Interlock Contact is closed (safe), the Interlock Relay energizes, allowing power to flow to the Control Relay; the corresponding front panel LED is on.
- When the Interlock Contact is open, the corresponding front panel LED flashes (locked out), the Interlock Relay is de-energized, preventing power from flowing to the Control Relay and the load.

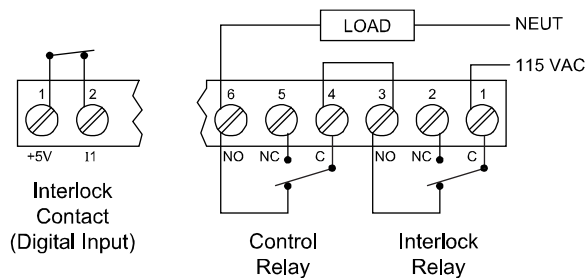

Figure 21. Interlock Connections

Switching Inductive Loads

The use of suppressors (snubbers) is strongly recommended when switching inductive loads to prevent disrupting the microprocessor's operation. The suppressors also prolong the life of the relay contacts. Suppression can be obtained with resistor-capacitor (RC) networks assembled by the user or purchased as complete assemblies. Refer to the following circuits for RC network assembly and installation:

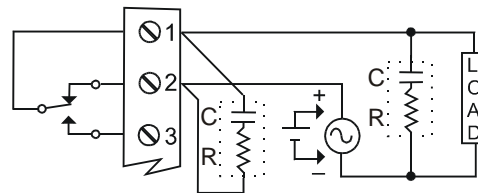

Figure 22. AC and DC Loads Protection

Choose R and C as follows:

R: 0.5 to 1 Ω for each volt across the contacts

C: 0.5 to 1 μF for each amp through closed contacts

Notes:

1. Use capacitors rated for 250 VAC.
2. RC networks may affect load release time of solenoid loads. Check to confirm proper operation.
3. Install the RC network at the totalizer's relay screw terminals. An RC network may also be installed across the load. Experiment for best results.

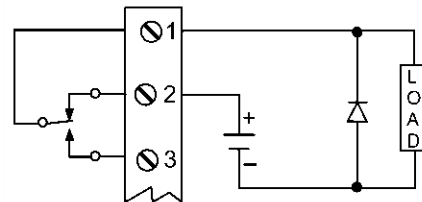

Use a diode with a reverse breakdown voltage two to three times the circuit voltage and forward current at least as large as the load current.

Figure 23. Low Voltage DC Loads Protection

RC Networks Available from Precision Digital

RC networks are available from Precision Digital and should be applied to each relay contact switching an inductive load. Part number: [PDX6901](#).

Note: Relays are de-rated to 1/14th HP (50 watts) with an inductive load.

Setup and Programming

There is **no need to recalibrate** the totalizer when first received from the factory. The totalizer is **factory calibrated** prior to shipment for milliamps and volts with calibration equipment that is certified to NIST standards.

Overview





There are no jumpers to set for the totalizer input selection. Setup and programming is done using MeterView Pro or through the programming buttons. After power and input signal connections have been completed and verified, apply power to the totalizer.

LED Status Indicators



LED	State	Indication
1-4	Steady	Alarm condition based on set and reset points, independent of relay status in certain configurations. (Available on all totalizer configurations, including those without relays installed)
1-4	Flashing	Relay interlock switch open
1-4 & M	Flashing	Relay in manual control mode
R	Steady	Rate
T	Steady	Total
T	Flashing	Totalizer in Tare mode
G & T	Steady	Grand Total
▲	Steady	Total overflow. ("oF" is displayed to the left of total overflow and ▲ LED is illuminated)
M	Flashing	Analog output in manual control mode
A	Steady	Channel A displayed
B	Steady	Channel B displayed
C	Steady	Channel C displayed

Programming Buttons

Button Symbol	Description
	Press to enter or exit Programming Mode, view settings, or exit max/min readings
	Press to reset max/min readings or other parameter/function assigned through the <i>User</i> menu
	Press to display max/min readings or other parameter/function assigned through the <i>User</i> menu
	Press to acknowledge relays or other parameters/function assigned through the <i>User</i> menu

- Press the Menu button to enter or exit the Programming Mode at any time.
- Press the Right arrow button to move to the next digit during digit or decimal point programming.
- Press or hold the Up arrow button to scroll through the menus, decimal point, or to increment the value of a digit.
- Press the Enter button to access a menu or to accept a setting.
- Press and hold the Menu button for three seconds to access the advanced features of the totalizer.

SafeTouch Buttons

The ProtEX-MAX is equipped with four sensors that operate as through-glass buttons so that it can be programmed and operated without removing the cover (and exposing the electronics) in a hazardous area.

These buttons can be disabled for security by selecting DISABLE on the switch labeled NO-CONTACT BUTTONS located on the connector board.

To actuate a button, press one finger to the glass directly over the marked button area. Then retract finger more than three inches from the glass before pressing the next button. When the cover is removed, the four mechanical buttons located next to the sensors are used. The sensors are disabled when a mechanical button is pressed and will automatically be re-enabled after 60 seconds of inactivity.

The SafeTouch Buttons are designed to filter normal levels of ambient interference and to protect against false triggering, however, it is recommended that the SafeTouch Buttons be disabled (slide switch to DISABLE) if there is an infrared interference source in line-of-sight to the display.

The SafeTouch Buttons are configured by default to duplicate the function of the front panel mechanical pushbuttons associated with the integrated controller. The symbols by each SafeTouch button correspond to a mechanical button as shown in the above table.

SafeTouch Button Tips:

- To the extent possible, install the display facing away from sunlight, windows, reflective objects and any sources of infrared interference.
- Keep the glass window clean.
- Tighten the cover securely.
- Use a password to prevent tampering.



Display Functions & Messages

The following table shows the main menu functions and messages in the order they appear in the menu.

Display	Parameter	Action/Setting Description
ሀይቲሆ	Setup	Enter Setup menu
ከሆሲ	Input	Enter Input selection menu
፮ከ-ጸ*	Input	Set input type for channel A (*or B)
ጠገጸ	4-20 mA	Set meter for 4-20 mA input
ህወሊኔ	0-10 VDC	Set meter for ±10 VDC input
ኔወሊጸ	Total	Enable/disable totalizer functions
ሃይሄ	Yes	Enable totalizer functions
ብዕ	No	Disable totalizer functions
ሠጠ ሳኔ	Unit	Select the display units/tags
፮ከ-ጸ*	Rate unit	Set rate unit or tag for channel A (*or B)
፮ከ-፫	Math unit	Set unit or tag for math channel C
ኔወሊ-ጸ*	Total unit	Set total unit or tag for channel A (*or B)
ህኔወሊ-ጸ*	Grand total unit	Set grand total unit or tag for channel A (*or B)
ወይሮ ፆኔ	Decimal point	Set decimal point
፮ከ-ጸ*	Decimal point	Set decimal point for channel A (*or B or C)
ገጸኔፎ*	Rate	Set rate decimal point (*channel A and B only)
ኔወሊጸ*	Total	Set total decimal point (*channel A and B only)
ህኔወሊጸ*	Grand total	Set grand total decimal point (*channel A and B only)
ፆሮፍ	Program	Enter the Program menu
ከ፫ጸጸ	Input calibration	Enter the Input Calibration menu
ሀ፫ጸጸ ጸ	Scale A	Enter the Scale menu for channel A
ሀ፫ጸጸ ሐ	Scale B	Enter the Scale menu for channel B
፫ጸጸ ጸ	Calibrate A	Enter the Calibration menu for channel A
፫ጸጸ ሐ	Calibrate B	Enter the Calibration menu for channel B
ከሆ ፋ	Input 1	Calibrate input 1 signal or program input 1 value
ወይ ፋ	Display 1	Program display 1 value

Display	Parameter	Action/Setting Description
ከሆ ፯	Input 2	Calibrate input 2 signal or program input 2 value (up to 32 points)
ወይ ፯	Display 2	Program display 2 value (up to 32 points)
ፎሮሮ	Error	Error, calibration not successful, check signal or programmed value
ኔሀይቲሆ	Total setup	Enter the Total Setup menu
፮ከ-ጸ*	Channel A	Setup the total for channel A (*or B)
ኔገሀይ	Time base	Program total time base
ኔ ፫ፆ	Total conversion factor	Program total conversion factor
ህኔ ፫ፆ	Grand total conversion factor	Program grand total conversion factor
ኔገሀይኔ	Total reset	Program total reset mode: auto or manual
፮ከ-ጸ*	Channel A	Set total reset modes for channel A (*or B)
ኔ ገሀይ	Total reset	Program total reset mode: auto or manual
ህኔ ገሀይ	Grand total reset	Program grand total reset mode: auto or manual
ኔ ወሊሃ	Time delay	Program automatic reset time delay
ወይፆጸሃ	Display	Enter the Display menu
፫ ጠፎ 1	Line 1	Assign the main display parameter
፫ ጠፎ ፯	Line 2	Assign the second display parameter
ወይ ፮ከ-ጸ	Display Ch-A	Assign display to channel A
ወይ ፮ከ-ሐ	Display Ch-B	Assign display to channel B
ወይ ፮ከ-፫	Display Ch-C	Assign display to channel C (math)
ወይ ጸሐ	Display AB	Alternate display of channel A & B
ወይ ጸ፫	Display AC	Alternate display of channel A & C
ወይ ሐ፫	Display BC	Alternate display of channel B & C
ወይ ጸሐ፫	Display ABC	Alternate display of channel A, B, & C
ወይ ኔ-ጸ	Display total A	Assign display to channel A total
ወይ ኔ-ሐ	Display total B	Assign display to channel B total
ወይ ህኔ-ጸ	Display grand total A	Assign display to channel A grand total

Display	Parameter	Action/Setting Description
d ƒt-b	Display grand total B	Assign display to channel B grand total
d rt-R	Display rate and total A	Alternate display of channel A rate and total
d rt-b	Display rate and total B	Alternate display of channel B rate and total
dr ƒt-R	Display rate and grand total A	Alternate display of channel A rate and grand total
dr ƒt-b	Display rate and grand total B	Alternate display of channel B rate and grand total
d 5Et i*	Display Set 1*	Displays relay 1 (*through 4) set point.
d H i-R	Display high A	Display high value of channel A
d Lo-R	Display low A	Display low value of channel A
d HL-R	Display high/low A	Alternate between high/low value of channel A
d H i-b	Display high B	Display high value of channel B
d Lo-b	Display low B	Display low value of channel B
d HL-b	Display High/low B	Alternate between high/low value of channel B
d H i-ƒ	Display high C	Display high value of channel C
d Lo-ƒ	Display low C	Display low value of channel C
d HL-ƒ	Display High/low C	Alternate between high/low value of channel C
d R-u	Display A and units/tags	Alternate display of channel A and the unit/tag
d b-u	Display B and units/tags	Alternate display of channel B and the unit/tag
d ƒ-u	Display C and units/tags	Alternate display of channel C and the unit/tag
d tR-u	Display total A and total units A	Alternate display of channel A total and total units
d tb-u	Display total B and total units B	Alternate display of channel B total and total units
d tRb	Display total A and B	Alternate display of channel A total and channel B total

Display	Parameter	Action/Setting Description
d tRbƒ	Display total A, B, and math channel C	Alternate display of channel A total, channel B total, and math result channel C
nr bu5	Display Modbus	Display Modbus input register
d oFF	Display off	Display blank line 2
d un ƒ	Display unit	Display line 1 channel units
d- ƒntƒ	Display intensity	Set display intensity level from 1 to 8
r ƒLRƒ	Relay	Enter the Relay menu
R55 ƒn	Assignment	Assign relays to channels or Modbus
R5 ƒn i*	Assign 1	Relay 1 (*through 4) assignment
ƒh-R*	Channel A*	Assign relay to channel A (*or B or C)
rRtE*	Rate	Assign relay to rate (*channel A and B only)
toƒRL*	Total	Assign relay to total (*channel A and B only)
ƒtoƒRL*	Grand total	Assign relay to grand total (*channel A and B only)
nr bu5	Modbus	Assign relay to Modbus register
r ƒY i*	Relay 1	Relay 1 (*through 4) setup
Rct i	Action 1	Set relay 1 action
Ruto	Automatic	Set relay for automatic reset
5Et i	Set 1	Enter relay 1 set point
r5t i	Reset 1	Enter relay 1 reset point
R-nRn	Auto-manual	Set relay for auto or manual reset any time
LRtƒH	Latching	Set relay for latching operation
ƒt-ƒLr	Latching-cleared	Set relay for latching operation with manual reset only after alarm condition has cleared
RtE r n	Alternate	Set relay for pump alternation control
5Rn r PL	Sample	Set relay for sample time trigger control
OFF	Off	Turn relay off
FR ƒLSF	Fail-safe	Enter Fail-safe menu
ƒLS i*	Fail-safe 1	Set relay 1 (*through 4) fail-safe operation
on	On	Enable fail-safe operation
oFF	Off	Disable fail-safe operation
d ƒLRƒ	Delay	Enter relay Time Delay menu

Display	Parameter	Action/Setting Description
dLY 1*	Delay 1	Enter relay 1 (*through 4) time delay setup
On 1	On 1	Set relay 1 On time delay
OFF 1	Off 1	Set relay 1 Off time delay
brERRH	Loop break	Set relay condition if loop break detected
brERRH 1*	Break 1	Set relay 1 (*through 4) break condition
Ignore E	Ignore	Ignore loop break condition (Processed as a low signal condition)
On	On	Relay goes to alarm condition when loop break detected
OFF	Off	Relay goes to non-alarm condition when loop break detected
Rout	Analog output	Enter the Analog output scaling menu
Rout 1	Aout Channel	Analog Output source channel
d 1 1	Display 1	Program display 1 value
Out 1	Output 1	Program output 1 value (e.g. 4.000 mA)
d 1 2	Display 2	Program display 2 value
Out 2	Output 2	Program output 2 value (e.g. 20.000 mA)
rESEt	Reset	Press Enter to access the Reset menu
rSt H 1	Reset high	Press Enter to reset max display
rSt Lo	Reset low	Press Enter to reset min display
rSt HL	Reset high & low	Press Enter to reset max & min displays
tot A	Reset total A	Press Enter to reset channel A total
tot b	Reset total B	Press Enter to reset channel B total
tot A	Reset grand total A	Press Enter to reset channel A grand total
tot b	Reset grand total B	Press Enter to reset channel B grand total
tot Ab	Reset totals A and B	Press Enter to reset channels A and B totals
tot Ab	Reset grand totals A and B	Press Enter to reset channels A and B grand totals
Control	Manual Control	Enter Manual Control menu
Auto	Automatic	Press Enter to set meter for automatic operation

Display	Parameter	Action/Setting Description
MAN	Manual	Press Enter to manually control relays or analog output operation
PR55	Password	Enter the Password menu
PR55 1	Password 1	Set or enter Password 1
UnLoCK	Unlocked	Program password to lock meter
LoCK	Locked	Enter password to unlock meter
PR55 2	Password 2	Set or enter Password 2
PR55 3	Password 3	Set or enter Password 3
tot RL	Total reset password	Set or enter a total reset password
tot RL	Grand total password	Set or enter a grand total reset password
999999 -99999	Flashing	Over/under range condition

Main Menu

The main menu consists of the most commonly used functions: *Reset, Manual Control, Setup, and Password.*

- Press Menu button to enter Programming Mode then press the Up arrow button to scroll main menu.
- Press Menu, at any time, to exit and return to Run Mode. Changes made to settings prior to pressing Enter are not saved.
- Changes to the settings are saved to memory only after pressing Enter.
- The display moves to the next menu every time a setting is accepted by pressing Enter.

Setting Numeric Values

The numeric values are set using the Right and Up arrow buttons. Press Right arrow to select next digit and Up arrow to increment digit value. The digit being changed is displayed brighter than the rest.

Press and hold up arrow to auto-increment the display value. If negative numbers are allowed, the first digit position will include a negative symbol (-) after the 9. Press the Enter button, at any time, to accept a setting or Menu button to exit without saving changes.

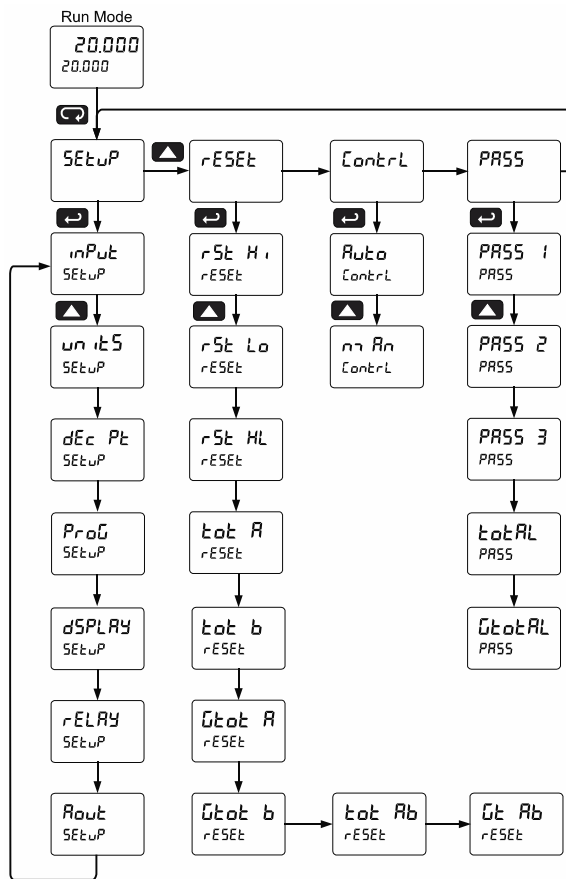
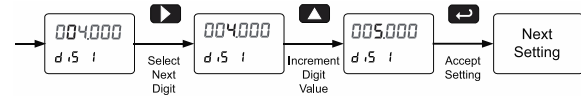

Setting Up the Totalizer (SEtUP)

The Setup menu is used to select:

1. Input signal the totalizer will accept for channel A and channel B
2. Units for A & B rate, total & grand total, and C
3. Decimal positions for A & B rate, total, and grand total, and C
4. Program the totalizer using the scale, calibrate, & total functions
5. Display parameters and intensity
6. Relay assignments and operation
7. 4-20 mA analog output scaling

Press the Menu button to exit at any time.

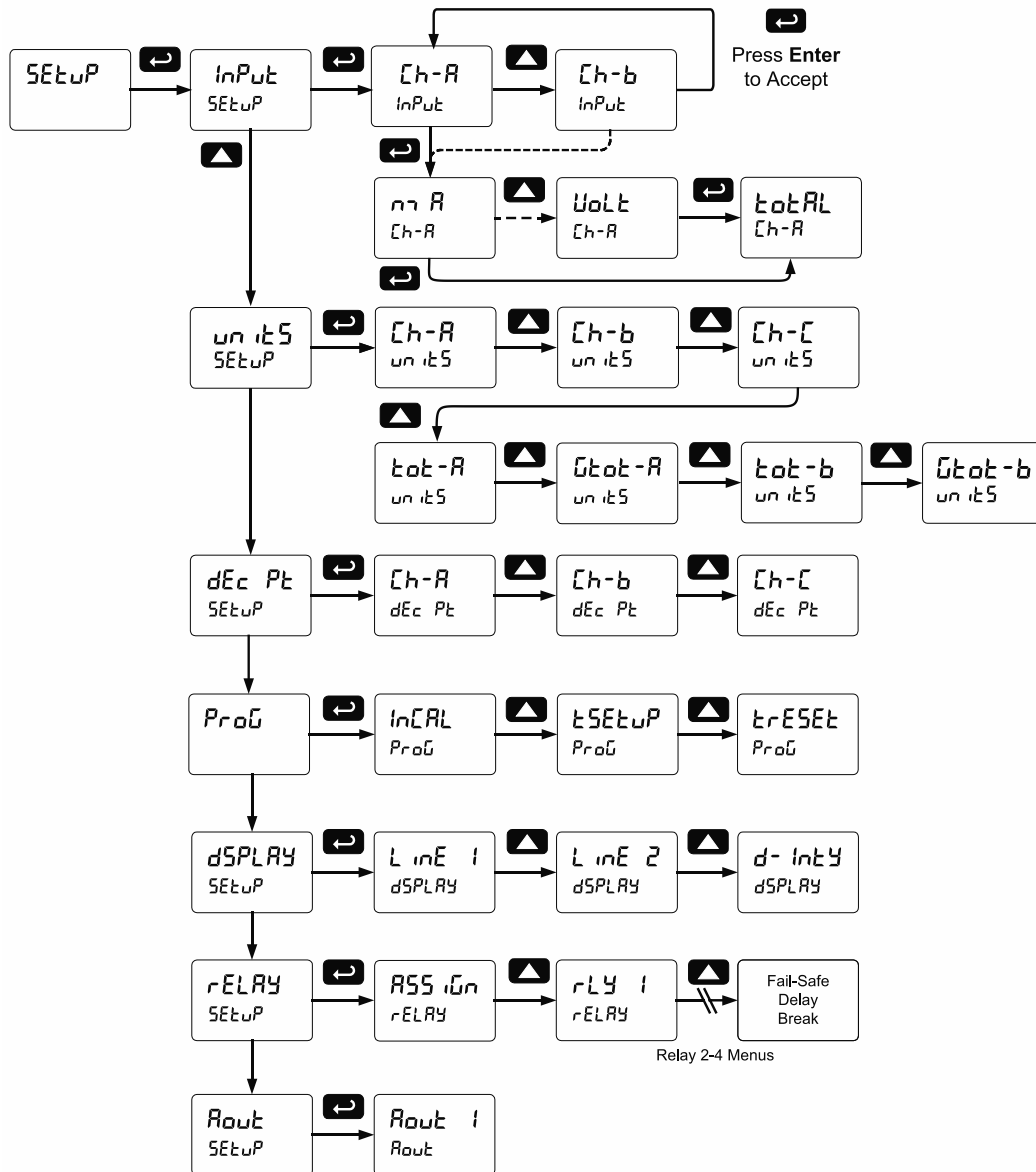

Setting the Input Signal (InPut)

Enter the *Input* menu to set up the totalizer to display current (n R) or voltage (u o L t) inputs for channel A and channel B.

The current input is capable of accepting any signal from 0 to 20 mA. Select current input to accept 0-20 mA or 4-20 mA signals.

The voltage input is capable of accepting any signal from -10 to +10 VDC. Select voltage input to accept 0-5, 1-5, 0-10, or ±10 VDC signals.

Channel C is the Math Function calculation, which is set up in the Advanced Features menu.

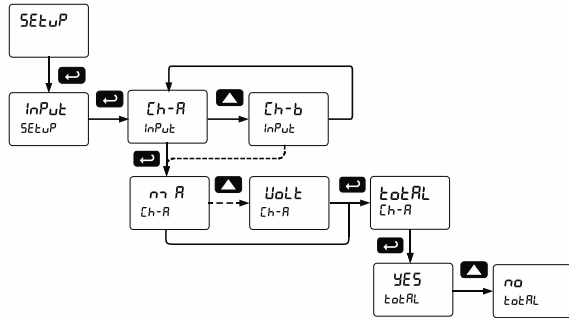

Setting the Totalizer Features (t o t a l)

To simply not display the total, select alternative display parameters in the display (d S P L A Y) menu. Enable or disable the totalizer features by selecting "Y E S" or "n o" after the input type has been set up for each channel. If the totalizer features are disabled, all the totalizer features and functions are hidden from the menus. Level and process totalizer features and functions are added to the menus.

If disabling the t o t a l parameter by selecting n o, please refer to the [PD8-6060](#) manual for instructions on setting up the totalizer parameters.

Notes:

1. The totalizer continues working in the background.
2. When selecting "no" for Total for a channel, the totalizer now functions as a PD8-6060 Dual-Input Process Meter for parameters that affect that channel. We **strongly** suggest that you download and use the [PD8-6060](#) instruction while in this mode of operation.

Setting the Rate, Total, & Grand Total Units/Tags (u n i t s)

Enter the channel A and B rate, total, grand total, and math channel C units (or custom tags) that will be displayed if alternating units is selected in the u n i t s menu, or d u n i t is selected as the second display parameter.

See the *Setting the Display Parameters & Intensity (d S P L A Y)* flow chart on page 40 for details on accessing the *Units* menu and parameters. [h - R and [h - b set the rate units, t o t - R and t o t - b the total units, and g r a n d - R and g r a n d - b the grand total units. [h - C sets the units for the math channel C.

See the *Setting the Display Parameters & Intensity (d S P L A Y)* flow chart on page 40 to access the display menu to show the unit or tag on the second display.

The engineering units or custom legends can be set using the following 7-segment character set:

Display	Character
0	0
1	1
2	2
3	3
4	4
5	5
6	6
7	7
8	8
9	9
A	A
b	b
C	C
c	c
d	d
E	E
F	F
G	G
g	g
H	H
h	h
I	I
i	i
J	J

Display	Character
K	K
L	L
m	m
n	n
O	O
o	o
P	P
q	q
r	r
S	S
t	t
u	u
v	v
w	w
X	X
Y	Y
Z	Z
-	-
/	/
[]
]	[
=	=
Degree(<)	Degree(<)
Space	Space

Notes:

1. Degree symbol represented by (<) if programming with MeterView Pro.
2. The letters "m" and "w" use two 7-segment LEDs each; when selected the characters to the right are shifted one position.
3. Press and hold up arrow to auto-scroll the characters in the display.

Setting the Decimal Point (dEc Pt)

The decimal point for any channel, rate, total, or grand total, may be set with up to five decimal places or with no decimal point at all.

Pressing the Right arrow moves the decimal point one place to the right until no decimal point is displayed, and then it moves to the leftmost position. Pressing the Up arrow moves the decimal point one place to the left.

There are seven decimal points to set up for three channels: Ch-A rate, total, and grand total; Ch-B rate, total, and grand total; and Ch-C.

After the decimal points are set up, the totalizer moves to the Program menu.

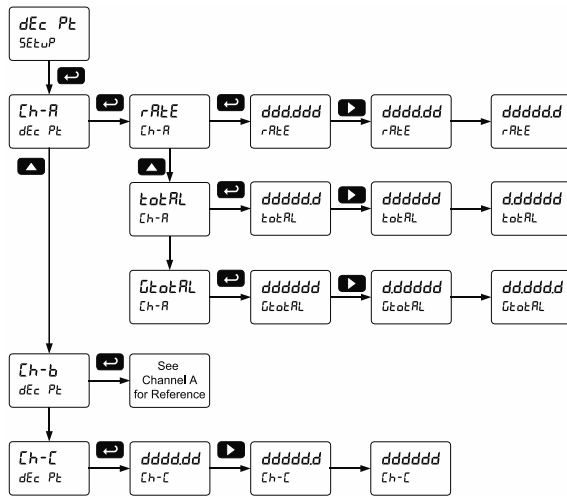

Programming the Rate/Totalizer (PrOG)

The totalizer may either be scaled (SEtRL) without applying an input or calibrated (LR) by applying an input. The totalizer comes factory calibrated to NIST standards, so for initial setup, it is recommended to use the (SEtRL) function.

The Program menu contains the following menus:

1. Scale channel A and B without a signal source
2. Calibrate channel A and B with a calibrated signal source
3. Channel A and B total time base & conversion factors
4. Channel A and B grand total time base & conversion factors
5. Channel A and B reset modes for total & grand total

The process inputs may be calibrated or scaled to any display value within the range of the totalizer.

Note: The **Scale** and **Calibrate** functions are exclusive of each other. The totalizer uses the last function programmed. Only one of these methods can be employed at a time. The Scale and Calibrate functions can use up to 32 points (default is 2). The number of points should be set in the Advanced menu prior to scaling and calibration of the totalizer. See *Multi-Point Linearization (LR)* menu on page 56 for details.

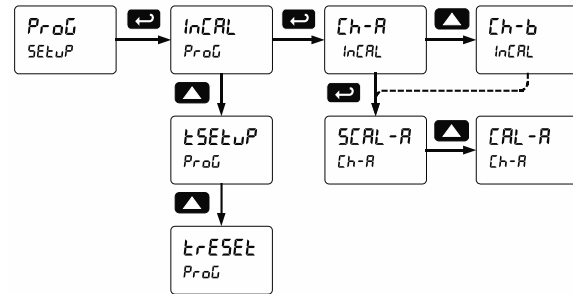

Additional parameters, not needed for most applications, are found in the *Advanced Features* menu; see *Advanced Features Menu* on page 52.

Input Calibration Method (InCRl)

There are two methods of calibrating (or scaling) the display for each input channel to show the correct engineering units.

- Use the *Scale* menu to enter the scaling without a signal source.
- Use the *Calibrate* menu to apply a signal from a signal source.

Note: The Scale and Calibrate functions are exclusive of each other. The totalizer uses the last function programmed. Only one of these methods can be employed at a time. The Scale and Calibrate functions can use up to 32 points (default is 2). The number of points should be set in the Advanced menu prior to scaling and calibration of the totalizer. See *Multi-Point Linearization (LnERR)* menu on page 56 for details.

Scaling the Totalizer without a Signal Source (SCRL-R, SCRL-b)

The process inputs (4-20 mA, ±10 VDC) can be scaled to display the process variables in engineering units. A signal source is not needed to scale the totalizer; simply program the inputs and corresponding display values.

From the InCRl menu, select channel A or B, followed by SCRL-R or SCRL-b, and then set the input signal value and display value for each of the scaling points (default is two).

Scaling the Totalizer for Channel A (SCRL-R)

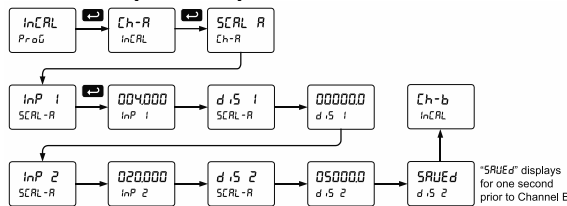

Scaling the Totalizer for Channel B (SCRL-b)

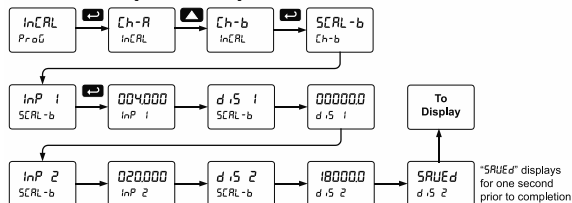

For instructions on how to program numeric values see *Setting Numeric Values*, page 34.

Error Message (Error)

An error message indicates that the calibration or scaling process was not successful.

After the error message is displayed, the totalizer reverts to input 2 during calibration or scaling and to input 1 during internal calibration, allowing the appropriate input signal to be applied or programmed.

The error message might be caused by any of the following conditions:

1. Input signal is not connected to the proper terminals or it is connected backwards.
2. Wrong signal selection in *Setup* menu.
3. Minimum input span requirements not maintained.
4. Input 1 signal inadvertently applied to calibrate input 2.

Minimum Input Span

The minimum input span is the minimum difference between input 1 and input 2 signals required to complete the calibration or scaling of the totalizer.

Input Range	Input 1 & Input 2 Span
4-20 mA	0.15 mA
±10 VDC	0.10 VDC

IMPORTANT

- **Reverse Scaling**
The controller can be scaled so that 4 mA represents the high end of the process value range being measured by the transmitter and 20 mA represents the low end of the process value range.

Calibrating the Totalizer with External Source

To scale the totalizer without a signal source, refer to *Scaling the Totalizer without a Signal Source* (5CR L - R, 5CR L - b) on page 38.

The totalizer can be calibrated to display the process variables in engineering units by applying the appropriate input signal and following the calibration procedure.

The use of a calibrated signal source is strongly recommended to calibrate the totalizer.

Warm up the totalizer for at least 15 minutes before performing calibration to ensure specified accuracy.

Calibrating the Totalizer for Channel A (CR L - R)

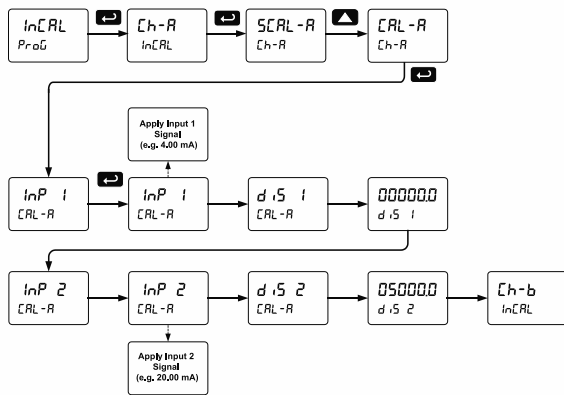

Note: Inputs for the above example are:
 Input 1: 4.00 mA; Display 1: 0.0 Gallons
 Input 2: 20.00 mA; Display 2: 5000.0 Gallons

Calibrating the Totalizer for Channel B (CR L - b)

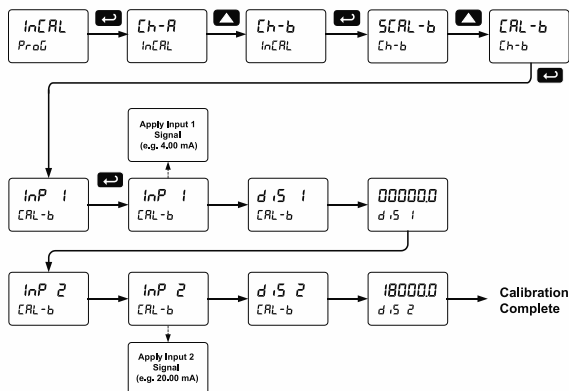

Note: Inputs for the above example are:
 Input 1: 4.00 mA; Display 1: 0.0 Gallons
 Input 2: 20.00 mA; Display 2: 18000.0 Gallons

Total & Grand Total Setup (t5Et uP)

The time base and total conversion factor, and grand total conversion factor for input channels A and B are located in the *Totalizer Setup* menu.

The time base is based on the rate of flow. Total & grand total conversion factors for channel A and B are programmed independently. The total and grand total have their own independent settings. This means that one can be displaying the value in gallons while the other displays in million gallons, liters, m³, etc.

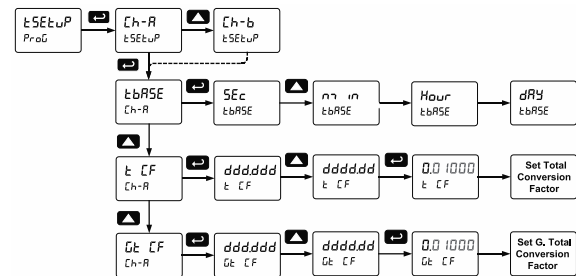

Total & Grand Total Reset

Total reset menus are located in the *Program* menu.

The totals can be programmed for manual or automatic reset. In the automatic reset mode, a programmable time delay is available to reset the total or grand total after the assigned preset is reached.

The totals can also be reset via the front panel button, via a switch across the F4 terminal, digital inputs, or via a Modbus command.

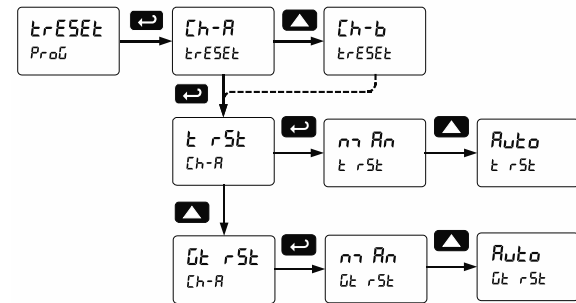

Password Protected and Non-Resettable Total

The total and grand total can be password-protected to prevent unauthorized resets. The grand total can be programmed as a non-resettable total, see *Total Reset Password & Non-Resettable Total* on page 51 for details.

Setting the Display Parameters & Intensity (dSPLY)

Display line 1 (LINE 1) can be programmed to display:

1. Ch-A rate (d [h-R)
2. Ch-B rate (d [h-b)
3. Ch-C math channel (d [h-C)
4. Toggle Ch-A & Ch-B rate (d Rb)
5. Toggle Ch-A rate and Ch-C (d RL)
6. Toggle Ch-B rate and Ch-C (d bL)
7. Toggle Ch-A & Ch-B rate, and Ch-C (d RbL)
8. Ch-A total (d t-R)
9. Ch-B total (d t-b)
10. Ch-A grand total (d t-R)
11. Ch-B grand total (d t-b)
12. Toggle Ch-A rate and total (d r t-R)
13. Toggle Ch-B rate and total (d r t-b)
14. Toggle Ch-A rate and grand total (d r t-R)
15. Toggle Ch-B rate and grand total (d r t-b)
16. Relay set points (1-4) (dSEt 1 to dSEt 4)
17. Max, min, and max & min values for Ch-A, Ch-B, or Ch-C (d HLR to d HL-C)
18. Toggle Ch-A rate & units (d R-u)
19. Toggle Ch-B rate & units (d b-u)
20. Toggle Ch-C & units (d [h-u)
21. Toggle Ch-A total & units (d tR-u)
22. Toggle Ch-B total & units (d t b-u)
23. Toggle Ch-A total and Ch-B total (d tRb)
24. Toggle Ch-A total, Ch-B total, and the sum of total A + total B (d tRbL)*
25. Modbus input (m bUS)

*Note: The (C = sum of total A + total B) displayed with the selection (d tRbL) is different than the math channel C calculated under the Math menu functions. Example: (C = Rate Ch-A + Rate Ch-B).

Display line 2 (LINE 2) can be programmed to display:

1. All options for display line 1
2. Off, with no display (d OFF)
3. Engineering units for any single channel, total, or grand total

Display Parameter Menu

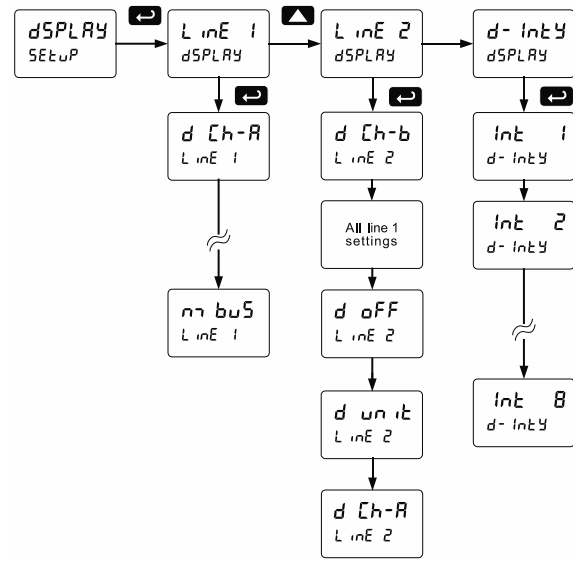

After setting up the input and display, press the Menu button to exit programming and skip the rest of the setup menu.

Customizable Displays

The displays can be set up to read input channels (A or B), rate, total, or grand total, math function channel C, toggle between A & B, B & C, A & C, A & B & C, toggle between channels A, B, or C & units, the max/min of any of the channels, including the math channel (C), set points, or the Modbus input. This allows the display to be setup to display whatever variables are most valuable to the application. Here are just a few examples.

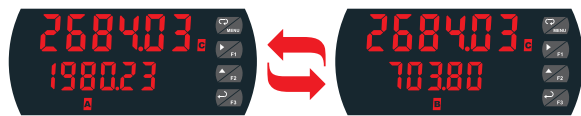

Line 1 displays Math Function (C)
Line 2 toggles between Totals A & B



Math Function & Tag

Input Channels
A & B Total

Display Intensity (d-INTY)

The totalizer has eight display intensity levels to give the best performance under various lighting conditions. Select intensity 8 for outdoor applications. The default intensity is 6.

Setting the Relay Operation (rELRY)

This menu is used to set up the assignment and operation of the relays.

CAUTION

- During setup, the relays do not follow the input and they will remain in the state found prior to entering the Relay menu.

1. Relay assignment
 - a. Channel A rate, total, or grand total
 - b. Channel B rate, total, or grand total
 - c. Channel C (Math channel)
 - d. Modbus
2. Relay action
 - a. Automatic reset only (non-latching)
 - b. Automatic + manual reset at any time (non-latching)
 - c. Latching (manual reset only)
 - d. Latching with Clear (manual reset only after alarm condition has cleared)
 - e. Pump alternation control (automatic reset only)
 - f. Sampling (the relay is activated for a user-specified time)
 - g. Off (relay state controlled by Interlock feature)
3. Set point
4. Reset point
5. Fail-safe operation
 - a. On (enabled)
 - b. Off (disabled)
6. Time delay
 - a. On delay (0-999.9 seconds)
 - b. Off delay (0-999.9 seconds)
7. Relay action for loss (break) of 4-20 mA input (ignore, on, off)

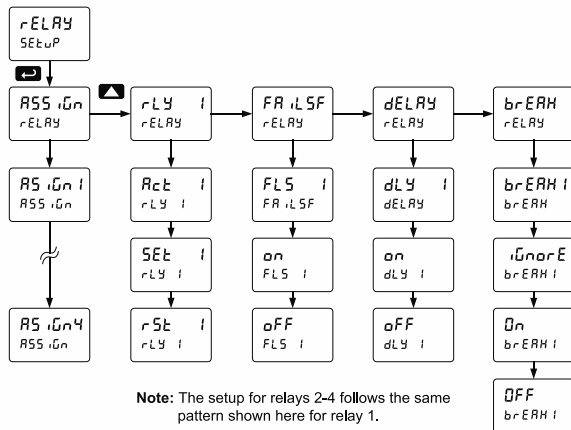

Note: The setup for relays 2-4 follows the same pattern shown here for relay 1.

Setting the Relay Assignment (ASSIGN)

Relays may be assigned to Channel A (rate, total, or grand total), Channel B (rate, total, or grand total), Channel C (Math channel), or Modbus input.

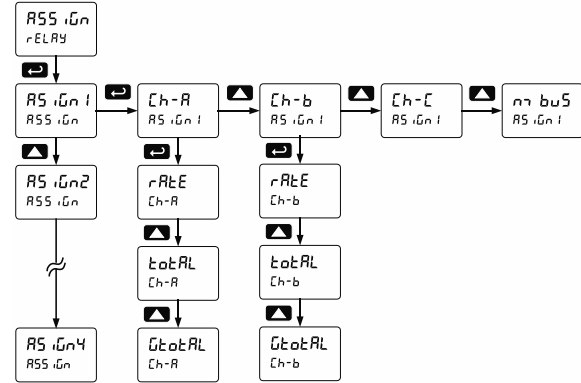

Setting the Relay Action (Act)

Operation of the relays is programmed in the Action menu. The relays may be set up for any of the following modes of operation:

1. Automatic reset (non-latching)
2. Automatic + manual reset at any time (non-latching)
3. Latching (manual reset only, at any time)
4. Latching with Clear (manual reset only after alarm condition has cleared)
5. Pump alternation control (automatic reset only)
6. Sampling (the relay is activated for a user-specified time)
7. Off (relay state controlled by Interlock feature)

The following graphic shows relay 1 action setup; relay 2-4 are set up in a similar fashion.

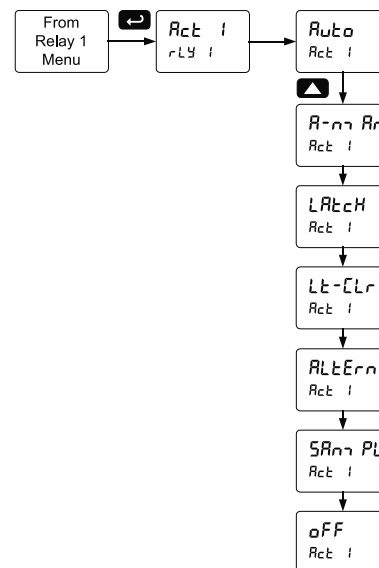

Programming Set and Reset Points

High alarm indication: program set point above reset point.

Low alarm indication: program set point below reset point.

The deadband is determined by the difference between set and reset points. Minimum deadband is one display count. If the set and reset points are programmed with the same value, the relay will reset one count below the set point.

Note: Changes are not saved until the reset point has been accepted.

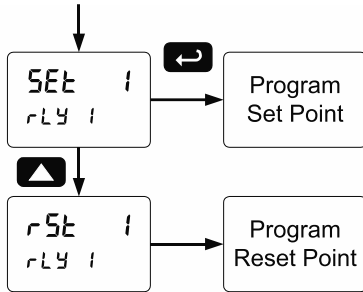

Setting Fail-Safe Operation

In fail-safe mode of operation, the relay coil is energized when the process variable is within safe limits and the relay coil is de-energized when the alarm condition exists. The fail-safe operation is set independently for each relay. Select **on** to enable or select **off** to disable fail-safe operation.

Programming Time Delay

The *On* and *Off* time delays may be programmed for each relay between 0 and 999.9 seconds. The relays will transfer only after the condition has been maintained for the corresponding time delay.

The *On* time delay is associated with the set point.

The *Off* time delay is associated with the reset point.

Relay Action for Loss of 4-20 mA Input (Loop Break)

The loop break feature is associated with the 4-20 mA input. Each relay may be programmed to go to one of the following conditions when the totalizer detects the loss of the input signal (i.e. < 0.005 mA):

1. Turn *On* (Go to alarm condition)
2. Turn *Off* (Go to non-alarm condition)
3. Ignore (Processed as a low signal condition)

Note: This is not a true loop break condition; if the signal drops below 0.005 mA, it is interpreted as a "loop break" condition.

The following graph shows the loop break relay operation for a high alarm relay.

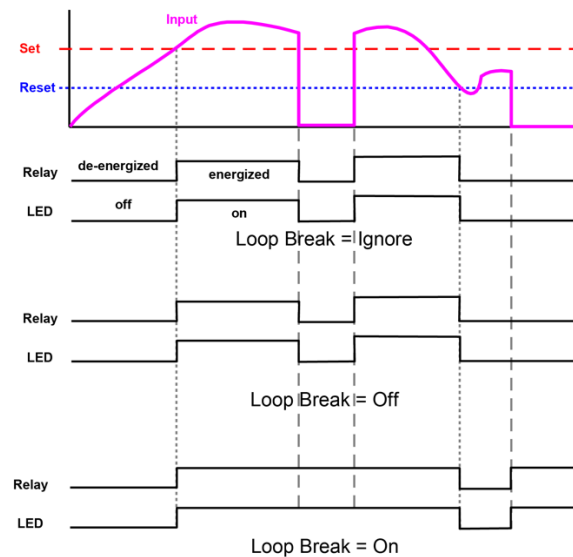

Relay and Alarm Operation Diagrams

The following graphs illustrate the operation of the relays, status LEDs, and ACK button.

High Alarm Operation (Set > Reset)

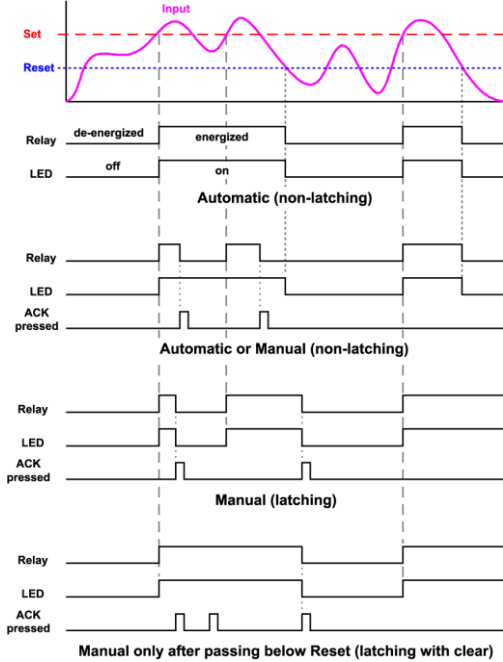

For Manual reset mode, ACK can be pressed anytime to turn "off" relay. To detect a new alarm condition, the signal must go below the set point, and then go above it.

Low Alarm Operation (Set < Reset)

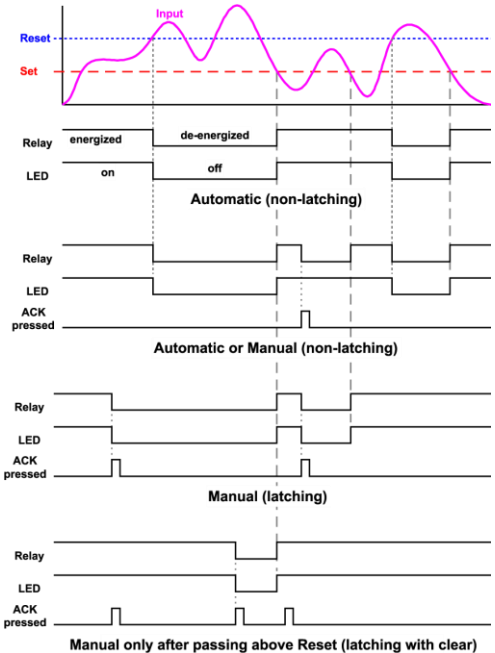

For Manual reset mode, ACK can be pressed anytime to turn "off" relay. To detect a new alarm condition, the signal must go below the set point, and then go above it.

High Alarm with Fail-Safe Operation (Set > Reset)

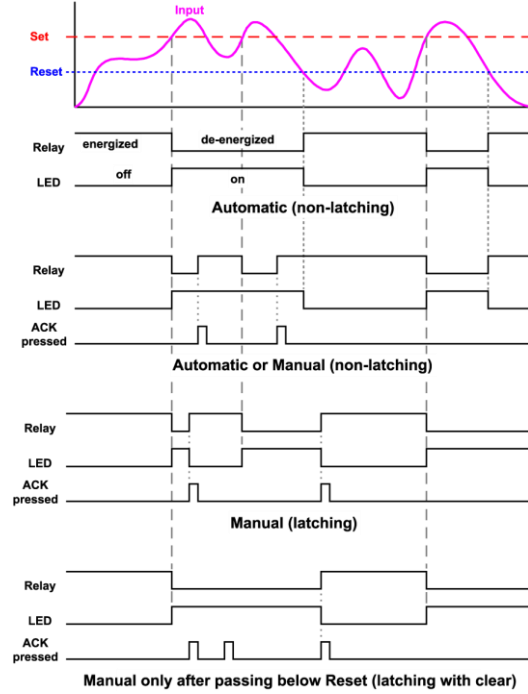

Note: Relay coil is energized in non-alarm condition. In case of power failure, relay will go to alarm state.

Low Alarm with Fail-Safe Operation (Set < Reset)

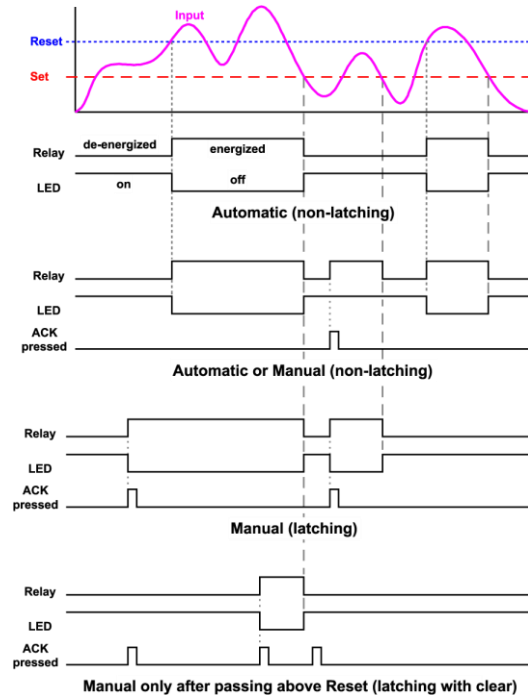

Note: Relay coil is energized in non-alarm condition. In case of power failure, relay will go to alarm state.

Time Delay Operation

The following graphs show the operation of the time delay function.

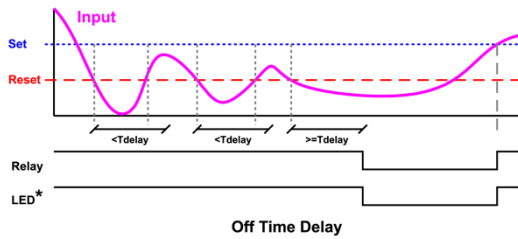
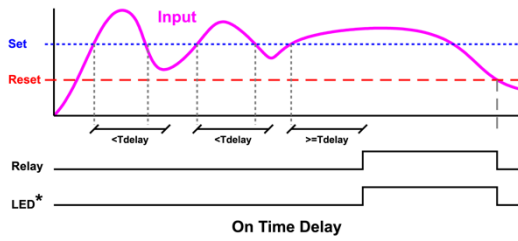

When the signal crosses the set point, the *On* time delay timer starts and the relay trips when the time delay has elapsed. If the signal drops below the set point (high alarm) before the time delay has elapsed, the *On* time delay timer resets and the relay does not change state. The same principle applies to the *Off* time delay.

Note: If "Automatic or Manual (R-n rRn)" reset mode is selected, the LED follows the reset point and not the relay state when the relay is acknowledged.

Total Relay Sampling Operation

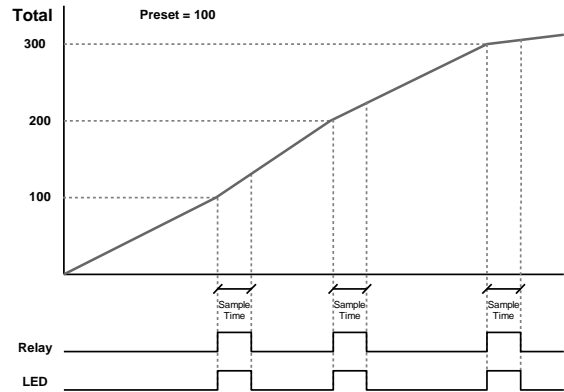

When the total reaches the preset, the relay trips and the sample time starts. After the sample time has elapsed, the relay resets. The cycle repeats every time the preset value is added to the total.

Pump Alternation Control Operation

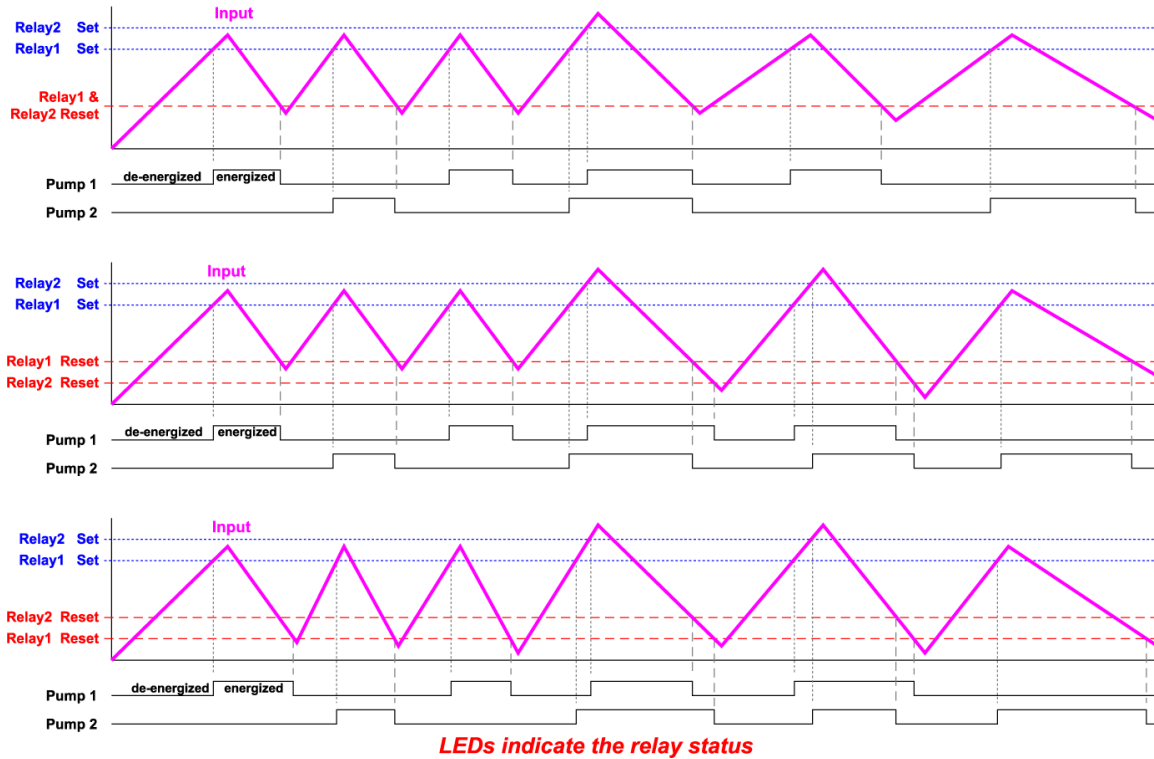

Relay Sampling Operation

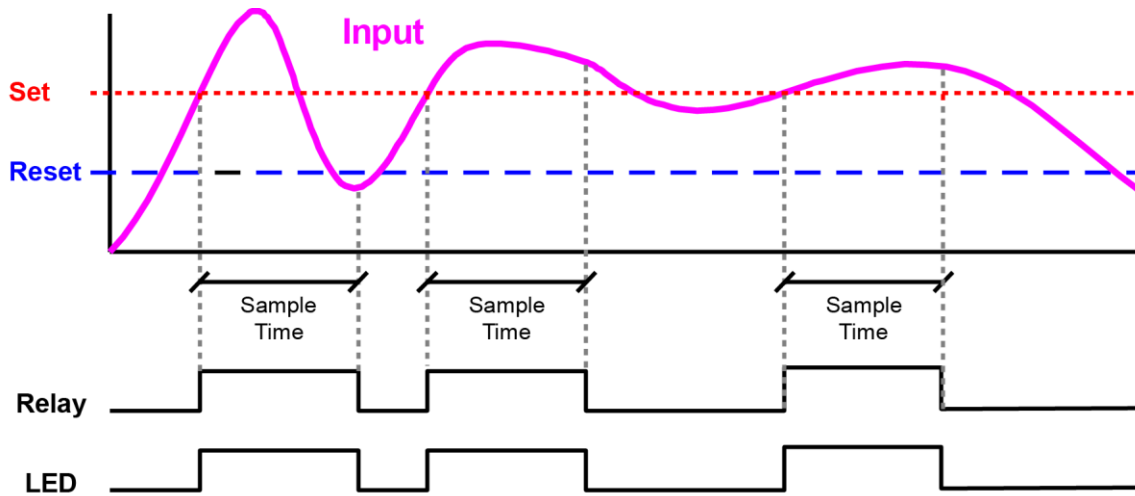

When the signal crosses the set point, the relay trips and the sample time starts. After the sample time has elapsed, the relay resets. The cycle repeats every time the set point is crossed, going up for high alarms and going down for low alarms.

The sample time can be programmed between 0.1 and 5999.9 seconds.

Relay Operation Details

Overview

The four-relays option for the totalizers expands its usefulness beyond simple indication to provide users with alarm and control functions. Typical applications include high and low temperature, level, pressure or flow alarms, control applications such as simple on/off pump control, and pump alternation control for up to 4 pumps. There are four basic ways the relays can be used:

1. High and Low Alarms with Latching or Non-Latching Relays
2. Simple On/Off Control with 100% Adjustable Deadband
3. Sampling (Based on Time)
4. Pump Alternation Control for up to 4 Pumps

Relays Auto Initialization

When power is applied to the totalizer, the front panel LEDs and alarm relays will reflect the state of the input to the totalizer. The following table indicates how the alarm LEDs and relays will react on power-up based on the set and reset points:

Alarm #	HI or LO Alarm	Set Point	Reset Point	Power-Up Reading	Relay & LED
1	HI	1000	500	499	Off
2	LO	700	900	499	On
3	LO	250	400	499	Off
4	HI	450	200	499	On

Fail-Safe Operation

The following table indicates how the relays behave based on the fail-safe selection for each relay:

Fail-Safe Selection	Non-Alarm State		Alarm State		Power Failure
	NO	NC	NO	NC	
Off	Open	Closed	Closed	Open	Relays go to non-alarm state
On	Closed	Open	Open	Closed	Relays go to alarm state

Note: NO = Normally Open, NC = Normally Closed. This refers to the condition of the relay contacts when the power to the totalizer is off.

Front Panel LEDs

The alarm status LEDs on the front panel are available on all totalizers, even those without relays installed, and provide status indication for the following:

LED	Status
1	Alarm 1
2	Alarm 2
3	Alarm 3
4	Alarm 4

The totalizer is supplied with four alarm points that include front panel LEDs to indicate alarm conditions. This standard feature is particularly useful for alarm applications that require visual-only indication. The LEDs are controlled by the set and reset points programmed by the user. When the display reaches a set point for a high or low alarm, the corresponding alarm LED will turn on. When the display returns to the reset point the LED will go off. The front panel LEDs responds differently for latching and non-latching relays.

For non-latching relays, the LED is always off during normal condition and always on during alarm condition, regardless of the state of the relay (e.g. Relay acknowledged after alarm condition).

For latching relays, the alarm LEDs reflects the status of the relays, regardless of the alarm condition. The following tables illustrate how the alarm LEDs function in relation to the relays and the acknowledge button (Default: F3 key assigned to ACK).

Latching and Non-Latching Relay Operation

The relays can be set up for latching (manual reset) or non-latching (automatic reset) operation.

Relay terminology for following tables	
Terminology	Relay Condition
On	Alarm (Tripped)
Off	Normal (Reset)
Ack	Acknowledged

The On and Off terminology does not refer to the status of the relay's coil, which depends on the fail-safe mode selected.

WARNING

- In latching relay mode, if Fail-Safe is off, latched relays will reset (unlatch) when power is cycled.

Non-Latching Relay (ᑭᓂᓂ)

In this application, the totalizer is set up for automatic reset (non-latching relay). Acknowledging the alarm while it is still present has no effect on either the LED or the relay. When the alarm finally goes away, the relay automatically resets and the LED also goes off.

Automatic reset only		
Condition	LED	Relay
Normal	Off	Off
Alarm	On	On
Ack (No effect)	On	On
Normal	Off	Off

Non-Latching Relay with Manual Reset (ᑭ-ᑎᑭᑭᑎ)

In this application, the totalizer is set up for automatic and manual reset at any time (non-latching relay). The LED and the relay automatically reset when the totalizer returns to the normal condition.

In addition, the relay can be manually reset while the alarm condition still exists, but the LED will stay on until the totalizer returns to the normal condition.

Automatic + manual reset at any time		
Condition	LED	Relay
Normal	Off	Off
Alarm	On	On
Normal	Off	Off
Next Alarm	On	On
Ack	On	Off
Normal	Off	Off

Latching Relay (ᑭᑭᓂᓂ)

In this application, the totalizer is set up for manual reset at any time. Acknowledging the alarm even if the alarm condition is still present resets the relay and turns off the LED.

Manual reset any time		
Condition	LED	Relay
Normal	Off	Off
Alarm	On	On
Ack	Off	Off

Latching Relay with Clear (ᑭᓂ-ᑭᓂᓂ)

In this application, the totalizer is set up for manual reset only after the signal passes the reset point (alarm condition has cleared). Acknowledging the alarm while it is still present has no effect on either the LED or the relay. When the alarm is acknowledged after it returns to the normal state, the LED and the relay go off. Notice that the LED remains on, even after the totalizer returns to the normal condition. This is because, for latching relays, the alarm LED reflects the status of the relay, regardless of the alarm condition.

Manual reset only after alarm condition has cleared		
Condition	LED	Relay
Normal	Off	Off
Alarm	On	On
Ack (No effect)	On	On
Normal	On	On
Ack	Off	Off

Acknowledging Relays

There are three ways to acknowledge relays programmed for manual reset:

1. Via the programmable front panel function keys F1-F3 (Example: F3 assigned to ACK).

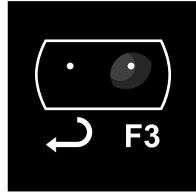

2. Remotely via a normally open push button wired to the F4 terminal.

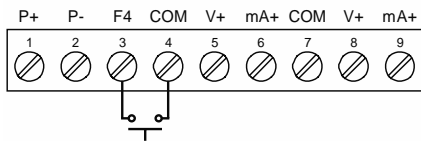

3. Remotely via a normally open push button wired to one of the digital inputs and the +5 V terminal on the digital I/O connections.

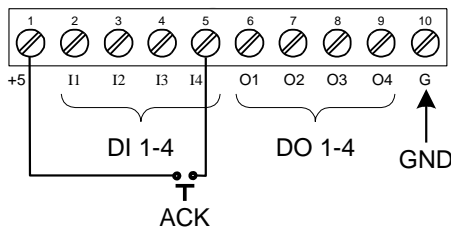

When the ACK button or the assigned digital input is closed, all relays programmed for manual reset are acknowledged.

Pump Alternation Control Applications (RL&E r n)

For pump control applications where two or more similar pumps are used to control the level of a tank or a well, it is desirable to have all the pumps operate alternately. This prevents excessive wear and overheating of one pump over the lack of use of the other pumps.

Up to 8 relays can be set up to alternate every time an on/off pump cycle is completed. The set points and reset points can be programmed, so that the first pump on is the first pump off.

Application #1: Pump Alternation Using Relays 1 & 2

1. Relays 1 and 2 are set up for pump alternation.
2. Relays 3 and 4 are set up for low and high alarm indication.

Set and Reset Point Programming			
Relay	Set Point	Reset Point	Function
1	30.000	10.000	Controls pump #1
2	35.000	5.000	Controls pump #2
3	4.000	9.000	Controls low alarm
4	40.000	29.000	Controls high alarm

Pump Alternation Operation

1. Pump #1 turns on when level reaches 30.000, when level drops below 10.000 pump #1 turns off.
2. The next time level reaches 30.000, pump #2 turns on, when level drops below 10.000, pump #2 turns off.
3. If the level doesn't reach 35.000 pump #1 and pump #2 will be operating alternately.
4. If pump #1 cannot keep the level below 35.000 pump #2 will turn on at 35.000, then as the level drops to 10.000 pump #1 turns off, pump #2 is still running and shuts off below 5.000.
5. Notice that with the set and reset points of pump #2 outside the range of pump #1, the first pump on is the first pump to go off. This is true for up to 8 alternating pumps, if setup accordingly.
6. Relay #3 will go into alarm if the level drops below 4.000 and relay #4 will go into alarm if the level exceeds 40.000.
7. Adding the 4 external relays expansion module allows using the 4 SPDT internal relays for pump alternation and the 4 SPST external relays for high, high-high, low, and low-low alarm indication.

Setting Up the Interlock Relay (Force On) Feature

Relays 1-4 can be set up as interlock relays. To set up the relays for the interlock feature:

1. Access the *Setup – Relay – Action* menu and set the action to off.

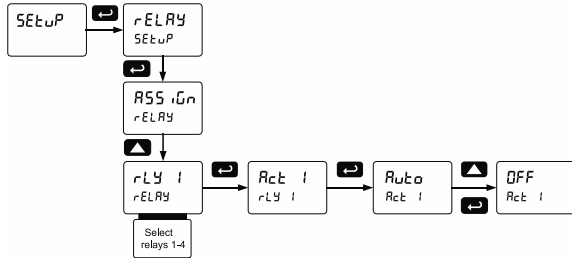

2. In the *Advanced features – User* menu program any of the digital inputs to *Force On* any of the internal relays (1-4).

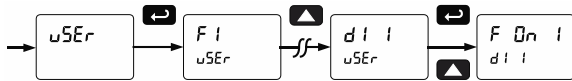

3. Connect a switch or dry contact between the +5V terminal and the corresponding digital input (dl-1 to dl-4) terminal.

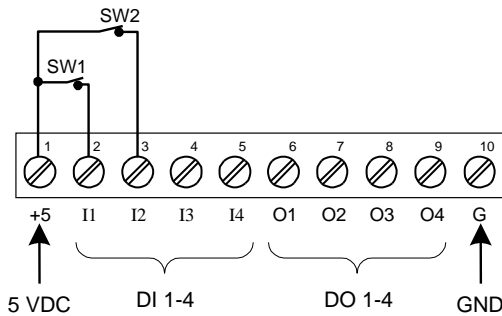

Interlock Relay Operation Example

Relays 1 & 2 are configured to energize (their front panel LEDs are steady on) when SW1 & SW2 switches (above) are closed. If the contacts to these digital inputs are opened, the corresponding front panel LEDs flash, indicating this condition. The processes being controlled by the interlock relay will stop, and will re-start only after the interlock relay is re-activated by the digital inputs (switches).

Note: If multiple digital inputs are assigned to the same relay, then the corresponding logic is (AND) – i.e. both switches must be closed to trip the relay.

IMPORTANT

- If the digital inputs are assigned to the *Interlock Function*, then they cannot be used to program the totalizer remotely.

Scaling the 4-20 mA Analog Output (Rout)

The 4-20 mA analog output can be scaled to provide a 4-20 mA signal for any display range selected. To select the channel and source assignments the analog output is assigned to, see *Analog Output Source* on page 58.

No equipment is needed to scale the analog output; simply program the display values to the corresponding mA output signal.

The *Analog Output* menu is used to program the 4-20 mA outputs based on display values.

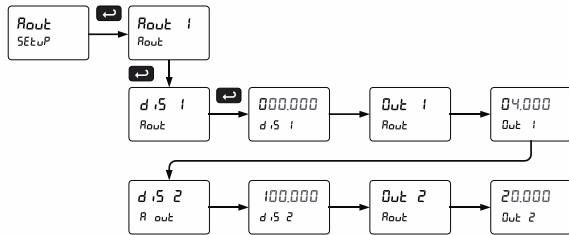

For further details, see *Setting Numeric Values* on page 34, *Analog Output Value for Loss of 4-20 mA Input (Loop Break)* on page 58.

Reset Menu (rESEt)

The *Reset* menu is used to reset the maximum (peak) value of Ch-A and Ch-B rate (r5t H i), minimum (valley) reading of Ch-A and Ch-B rate (r5t L o), both high and low value of Ch-A and Ch-B rate (r5t H L), Ch-A total (t o t A) or Ch-B total (t o t b), Ch-A grand total (G t o t A) or Ch-B grand total (G t o t b), both Ch-A and Ch-B totals (t o t A b), or both Ch-A and Ch-B grand totals (G t A b).

Manual Control Menu (Control)

The *Manual Control* menu is used to control the 4-20 mA analog output (Aout 1 only) and the relays manually, ignoring the input. Each relay and analog output can be programmed independently for manual control. Selecting automatic control sets all relays and analog output for automatic operation.

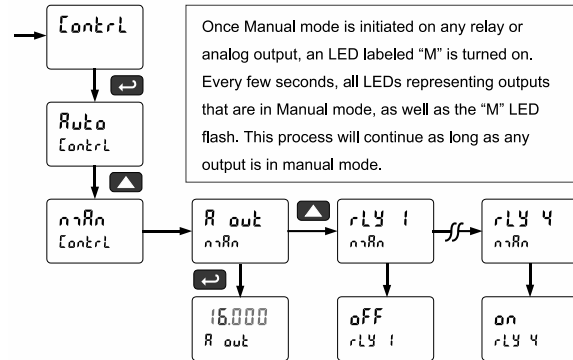

Setting Up the Password (PR55)

The *Password* menu is used for programming three levels of security to prevent unauthorized changes to the programmed parameter settings, to restrict the ability to reset the totals and grand totals, and to program the non-resettable totalizer.

- Pass 1: Allows use of function keys and digital inputs
- Pass 2: Allows use of function keys, digital inputs and editing set/reset points
- Pass 3: Restricts all programming, function keys, and digital inputs.
- Total: Prevents resetting the total manually
- Gtotal: Prevents resetting the grand total manually

Protecting or Locking the Totalizer Functions

Enter the *Password* menu and program a six-digit password.

For instructions on how to program numeric values see *Setting Numeric Values* on page 34.

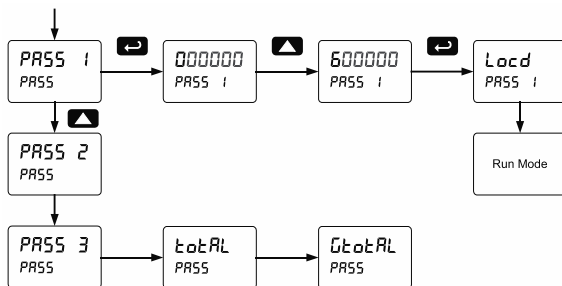

Total Reset Password & Non-Resettable Total

The total and the grand total can be password-protected to prevent unauthorized total resets.

The grand total can be programmed as a non-resettable total by entering the password "050873".

CAUTION

- Once the Grand Total has been programmed as "non-resettable" the feature **CANNOT** be disabled.

Making Changes to a Password Protected Totalizer

If the totalizer is password protected, the totalizer will display the message *Locd* (*Locked*) when the Menu button is pressed. Press the Enter button while the message is being displayed and enter the correct password to gain access the menu. After exiting the programming mode, the totalizer returns to its password protected condition.

Disabling Password Protection

To disable the password protection, access the *Password* menu and enter the correct password twice, as shown below. The totalizer is now unprotected until a new password is entered.

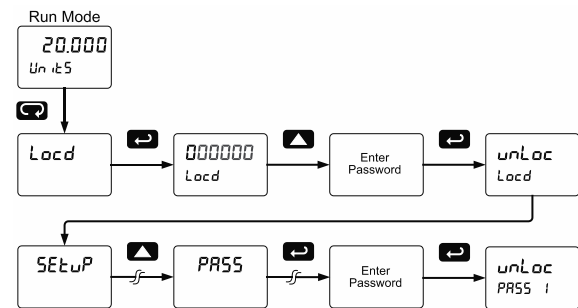

If the correct six-digit password is entered, the totalizer displays the message *unLoc* (*unlocked*) and the protection is disabled until a new password is programmed.

If the password entered is incorrect, the totalizer displays the message *Locd* (*Locked*) for about two seconds, and then it returns to Run Mode. To try again, press Enter while the *Locked* message is displayed.

Did you forget the password?

The password may be disabled by entering a master password once. If you are authorized to make changes, enter the master password 508655 to unlock the totalizer.

Advanced Features Menu

To simplify the setup process, functions not needed for most applications are located in the *Advanced Features* menu.

Press and hold the Menu button for three seconds to access the advanced features of the totalizer.

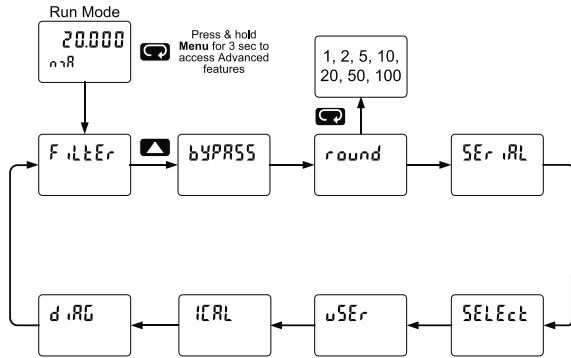

Advanced Features Menu & Display Messages

The following table shows the functions and messages of the *Advanced Features* menu in the order they appear in the menu.

Display	Parameter	Action/Setting
F.i.l.t.e.r	Filter	Set noise filter value
C.h.a.n.n.e.l A	Channel A	Set filter value for channel A
C.h.a.n.n.e.l B	Channel B	Set filter value for channel B
b.y.p.a.s.s	Bypass	Set filter bypass value
C.h.a.n.n.e.l A	Channel A	Set filter bypass value for channel A
C.h.a.n.n.e.l B	Channel B	Set filter bypass value for channel B
r.o.u.n.d	Round	Set the rounding value for display variables
S.E.R.I.A.L	Serial	Set serial communication parameters
S.l.a.v.e I.D	Slave ID	Set slave ID or meter address
b.a.u.d	Baud rate	Select baud rate
t.r.a.n.s.m.i.t d.l.a.y	Transmit delay	Set transmit delay for serial communication
P.a.r.i.t.y	Parity	Select parity Even, Odd, or None with 1 or 2 stop bits
t.i.m.e b.y.t.e	Time byte	Set byte-to-byte timeout
S.E.L.E.C.T	Select	Enter the Select menu (function, cutoff, out)
F.u.n.c.t.i.o.n	Input signal conditioning	Select linear, square root, programmable exponent, or round horizontal tank function
C.h.a.n.n.e.l A	Channel A	Select menu for channel A

Display	Parameter	Action/Setting
C.h.a.n.n.e.l B	Channel B	Select menu for channel B
L.i.n.e.a.r	Linear	Set meter for linear function and select number of linearization points
n.o. P.o.i.n.t.s	Number of points	Set the number of linearization points (default: 2)
S.q.u.a.r.e	Square root	Set meter for square root extraction
P.r.o.g.r.a.m.m.a.b.l.e e.x.p.o.n.e.n.t	Programmable exponent	Set meter for programmable exponent and enter exponent value
m.a.t.h	Math	Enter the setup menu for channel C math functions
S.u.m	Sum	$C = (A+B+P)*F$
d.i.f.f.	Difference	$C = (A-B+P)*F$
d.i.f.f.a.b.s.o.l.u.t.e d.i.f.f.e.r.e.n.c.e	Absolute difference	$C = ((\text{Absolute value of } (A-B)) + P)*F$
A.v.e.r.a.g.e	Average	$C = (((A+B)/2) + P)*F$
m.u.l.t.i.p.l.y	Multiplication	$C = ((A*B) + P)*F$
d.i.v.i.d.e	Divide	$C = ((A/B) + P)*F$
H.i.g.h o.f A o.r B	Max of A or B	$C = ((\text{High value of channel A or B}) + P)*F$
L.o.w.o.f A o.r B	Min of A or B	$C = ((\text{Low value of channel A or B}) + P)*F$
d.r.a.w	Draw	$C = ((A/B) - 1)*F$
w.e.i.g.h.t.e.d a.v.g.	Weighted avg.	$C = ((B-A)*F) + A$
r.a.t.i.o	Ratio	$C = (A/B)*F$
r.a.t.i.o 2	Ratio 2	$C = ((B-A)/A) + P)*F$
C.o.n.c.e.n.t.r.a.t.i.o.n	Concentration	$C = (A/(A+B))*F$
S.u.m t.o.t.a.l	Sum total	$C = (tA+tB+P)*F$
S.u.m g.r.a.n.d t.o.t.a.l	Sum grand total	$C = (GtA+GtB+P)*F$
d.i.f.f. t.o.t.a.l	Difference of total	$C = (tA-tB+P)*F$
d.i.f.f. g.r.a.n.d t.o.t.a.l	Diff. of grand total	$C = (GtA-GtB+P)*F$
t.o.t.a.l r.a.t.i.o	Total ratio	$C = (tA/tB)*F$
t.o.t.a.l r.a.t.i.o 2	Total ratio 2	$C = ((tB-tA)/tA)*F$
t.o.t.a.l p.e.r.c.e.n.t	Total percent	$C = (tA/(tA+tB))*100$
C.o.n.s.t.a.n.t	Constant	Enter math equation constants
A.d.d.e.r	Adder	Addition constant used in channel C math calculations (P)
F.a.c.t.o.r	Factor	Multiplication constant used in channel C math calculations (F)
C.u.t.o.f.f	Cutoff	Set low-flow cutoff
C.h.a.n.n.e.l A	Channel A	Set low-flow cutoff for Channel A

Advanced Features Menu & Display Messages		
Display	Parameter	Action/Setting
ከ-ፅ	Channel B	Set low-flow cutoff for Channel B
ጠባቢ	Count	Set total count direction
ከ-ጸ	Channel A	Set total count direction for Channel A
ከ-ፅ	Channel B	Set total count direction for Channel B
ጠባቢ	Total count	Set direction of total count
ጠባቢ	Grand total count	Set direction of grand total count
ሆ	Count up	Count up
ሙሥ	Count down	Count down
ፍ	Count start	Enter count down start value
ጸጠታ	Analog output programming	Program analog output parameters
ጸጠታ	Analog output	Program analog output parameters
ሥጦር	Source	Select source for the 4-20 mA output
ፅጥጫ	Loop break	Set analog output value if input loop break is detected
ጠባቢ	Calibrate	Calibrate 4-20 mA output (internal reference source used for scaling the output)
4 ጠባቢ	4 mA output	Enter mA output value read by milliamp meter with at least 0.001 mA resolution
20 ጠባቢ	20 mA output	Enter mA output value read by milliamp meter with at least 0.001 mA resolution
ሆ-ጸጠታ	Ovrange	Program mA output for display overrange
ሙ-ጸጠታ	Underrange	Program mA output for display underrange
ጠባቢ	Maximum	Program maximum mA output allowed
ጠባቢ	Minimum	Program minimum mA output allowed
ሆፍ	User I/O	Assign function keys and digital I/O
F 1	F1* function key	Assign F1 function key (*F1/F2/F3)
F4	F4 digital input	Assign F4 function (digital input)
d 1	Digital input 1	Assign digital input 1 – 4
d 1	Digital output 1	Assign digital output 1 – 4
ፍጠባቢ	Internal calibration	Enter internal calibration (used for recalibrating the meter with a calibrated signal source)
ከ-ጸ	Channel A	Perform calibration on channel A

Advanced Features Menu & Display Messages		
Display	Parameter	Action/Setting
ከ-ፅ	Channel B	Perform calibration on channel B
ፍ ጠባቢ	Current calibration	Calibrate 4-20 mA current input (internal reference source used for scaling the input)
ፍ ጠባ	Current low	Calibrate low current input (e.g. 4 mA)
ፍ ጠባ	Current high	Calibrate high current input (e.g. 20 mA)
ሆ ጠባቢ	Voltage calibration	Calibrate voltage input
ሆ ጠባ	Voltage low	Calibrate low voltage input (e.g. 0 V)
ሆ ጠባ	Voltage high	Calibrate high voltage input (e.g. 10 V)
d ጠባቢ	Diagnostics	Display parameter settings
ፍ ጠባ	LED test	Test all LEDs
ፍ ጠባ	Information	Display software number and version
ፍ ጠባ	Erase	Erase MeterView Pro software stored in meter's memory

Noise Filter (F ILTFR)

The noise filter is available for unusually noisy signals that cause an unstable process variable display. The noise filter averages the input signal over a certain period. The filter level determines the length of time over which the signal is averaged. The filter level can be set between 2 and 199. The higher the filter level, the longer the averaging time and so the longer it takes the display to settle to its final value. Setting the filter level to zero disables the filter function.

Noise Filter Bypass (bYPRSS)

The noise filter bypass changes the behavior of the totalizer so that small variations in the signal are filtered out but large abrupt changes in the input signal are displayed immediately. The bypass value determines the minimum amount of signal change to be displayed immediately. All signal changes smaller than the bypass value are filtered or averaged by the totalizer. The noise filter bypass may be set between 0.1 and 99.9% of full scale.

Rounding Feature (round)

The rounding feature is used to give the user a steadier display with fluctuating signals. Rounding is used in addition to the filter function.

Rounding causes the display to round to the nearest value according to the rounding selected. This setting affects the last two digits, regardless of decimal point position. See examples below:

Rounding Selection	Actual Value	Display Value	Actual Value	Display Value
1	12.022	12.022	12.023	12.023
5	12.022	12.020	12.023	12.025
10	12.024	12.020	12.025	12.030

Modbus RTU Serial Communications (SERIAL)

The totalizer is equipped with serial communications capability as a standard feature using Modbus RTU Serial Communication Protocol.

The totalizer may be connected to a PC for initial configuration via the onboard USB connection. For ongoing digital communications with a computer or other data terminal equipment, use the RS-485 connection with the appropriate serial converter; see *Ordering Information* on page 7 for details.

CAUTION

- **DO NOT** connect any equipment to the RJ45 M-LINK connector. Otherwise damage will occur to the equipment and the totalizer.
- **DO NOT** disconnect the RJ45 connector located to the left of the power terminal block. Doing so will disable the on-board digital I/O, and the RS-485 serial communications.

Notes:

1. More detailed instructions are provided with each optional serial communications adapter.
2. Refer to the ProtEX-MAX Modbus Register Tables located at www.predig.com for details.

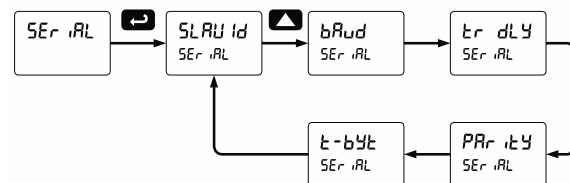

When using more than one totalizer in a multi-drop mode, each totalizer must be provided with its own unique address. The meter address (Slave ID) may be programmed between 1 and 247. The transmit delay may be set between 0 and 199 ms. The parity can be set to even, odd, or none with 1 or 2 stop bits.

Select Menu (SELEct)

The *Select* menu is used to select the input signal conditioner applied to the inputs (linear, square root, or programmable exponent), math function for A & B, constants, low-flow cutoff, total count direction (up or down from a preset amount), and analog output programming. Multi-point linearization is part of the linear function selection.

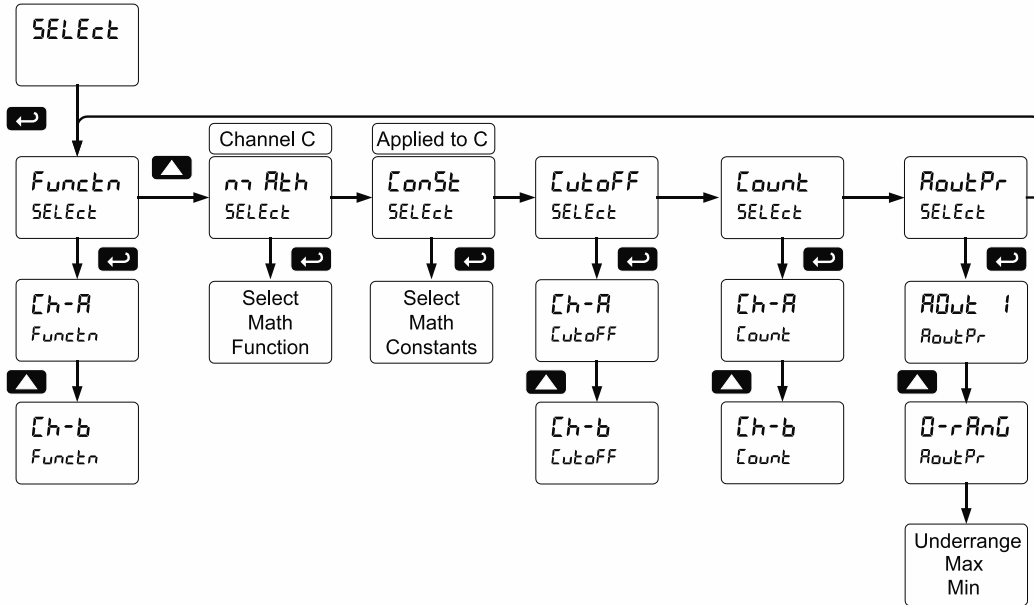

Input Signal Conditioning (Functn)

The *Function* menu is used to select the input signal conditioner applied to the input signal: linear, square root, or programmable exponent. Multi-point linearization is part of the linear function selection. Each input channel input signal conditioner is programmed independently.

Totalizers are set up at the factory for linear function with 2-point linearization. The linear function provides a display that is linear with respect to the input signal.

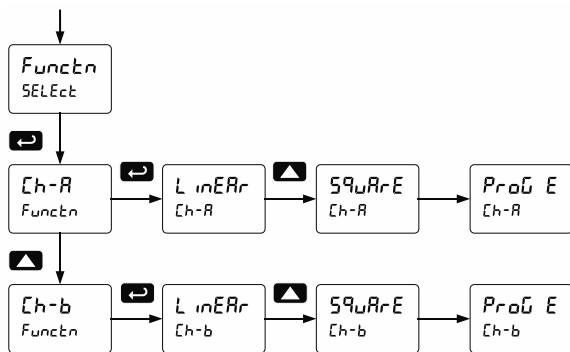

Square Root Linearization (SQURrE)

The square root function is used to calculate flow measured with a differential pressure transmitter. The flow rate is proportional to the square root of the differential pressure. Scale the totalizer so that the low input signal (e.g. 4 mA) is equal to zero flow and the high input signal (e.g. 20 mA) is equal to the maximum flow.

Programmable Exponent Linearization (PrOG E)

The programmable exponent function is used to calculate open-channel flow measured with a level transmitter in weirs and flumes. The flow rate is proportional to the head height. Scale the totalizer so that the low input signal (e.g. 4 mA) is equal to zero flow and the high input signal (e.g. 20 mA) is equal to the maximum flow. This method works well for all weirs and flumes that have a simple exponent in the flow calculation formula. For weirs and flumes with complex exponents it is necessary to use a strapping table and the 32-point linearization of the totalizer.

Multi-Point Linearization (L inERr)

Totalizers are set up at the factory for linear function with 2-point linearization. Up to 32 linearization points can be selected for each channel under the linear function. The multi-point linearization can be used to linearize the display for non-linear signals such as those from level transmitters used to measure volume in odd-shaped tanks or to convert level to flow using weirs and flumes with complex exponent.

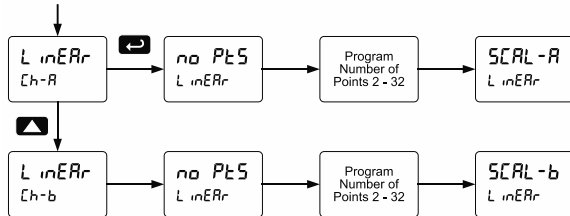

Note: After Scale is displayed continue pressing the Enter button until the totalizer completes the scaling of the input and display values.

Math Function (n-rAExh)

The *Math* menu is used to select the math function that will determine the channel C value. These math functions are a combination of input channels A and B, and will display when channel C is selected in the *Display* menu.

A and B refer to the rate of channel A and B. tA and tB refer to the totals of channel A and B. GtA and GtB refer to the grand totals of channel A and B. The following math functions are available.

Function	Display	Description
Sum	Sum	$C = (A+B+P)*F$
d.F	Difference	$C = (A-B+P)*F$
d.FRb5	Absolute difference	$C = ((\text{Absolute value of } (A-B))+P)*F$
RUG	Average	$C = (((A+B)/2)+P)*F$
n-rAExh	Multiplication	$C = ((A*B)+P)*F$
d.ü idE	Divide	$C = ((A/B)+P)*F$
H.-Rb	Max of A or B	$C = ((\text{High value of channel A or B})+P)*F$
L.-Rb	Min of A or B	$C = ((\text{Low value of channel A or B})+P)*F$
d.rRuu	Draw	$C = ((A/B)-1)*F$
uu.RUG	Weighted avg.	$C = ((B-A)*F)+A$
rREx	Ratio	$C = (A/B)*F$
rREx2	Ratio 2	$C = ((B-A)/A)+P*F$
ConcEn	Concentration	$C = (A/(A+B))*F$
Sum r	Sum total	$C = (tA+tB+P)*F$
Sum rGt	Sum grand total	$C = (GtA+GtB+P)*F$
d.F r	Difference of total	$C = (tA-tB+P)*F$
d.F rGt	Diff. of grand total	$C = (GtA-GtB+P)*F$
t.rREx	Total ratio	$C = (tA/tB)*F$
t.-rREx2	Total ratio 2	$C = ((tB-tA)/tA)*F$
t.Pct	Total percent	$C = (tA/(tA+tB))*100$

Math Constants (ConSt)

The *Math Constants* menu is used to set the constants used in channel C math. The math functions include adder constant P, and factor constant F.

The *Adder* constant (P) may be set from -99.999 to 999.999.

The *Factor* constant (F) may be set from 0.001 to 999.999.

The chart on page 56 details the math functions that may be selected in the *Math Function* menu.

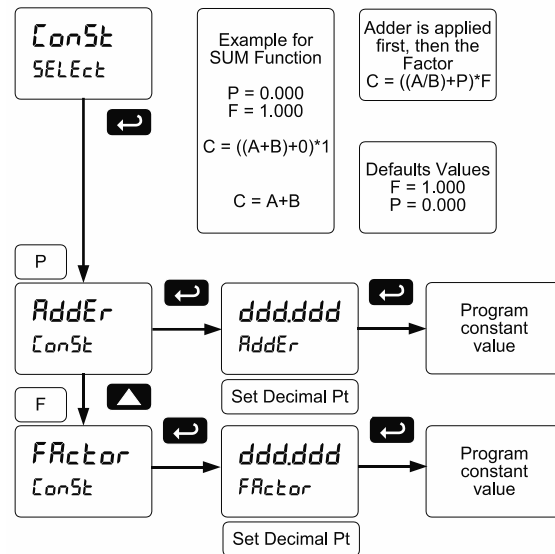

Low-Flow Cutoff (LütoFF)

The low-flow cutoff feature allows the totalizer to be programmed so that the often-unsteady output from a differential pressure transmitter, at low flow rates, always displays zero on the totalizer. The low-flow cutoff for each channel is programmed independently. The cutoff can be disabled to display negative values.

The cutoff value may be programmed from 0.1 to 999999. The totalizer will display zero below the cutoff value. Programming the cutoff value to zero disables the cutoff feature. The cutoff can be disabled to display negative values.

Totalizer Count Up/Down (Count)

The totalizer count up/down menu may be used to program the total and grand total to either count up from 0 when reset or count down from a programmed value when reset. Total and grand total may have their countdown numbers programmed individually from 0 to 999999.

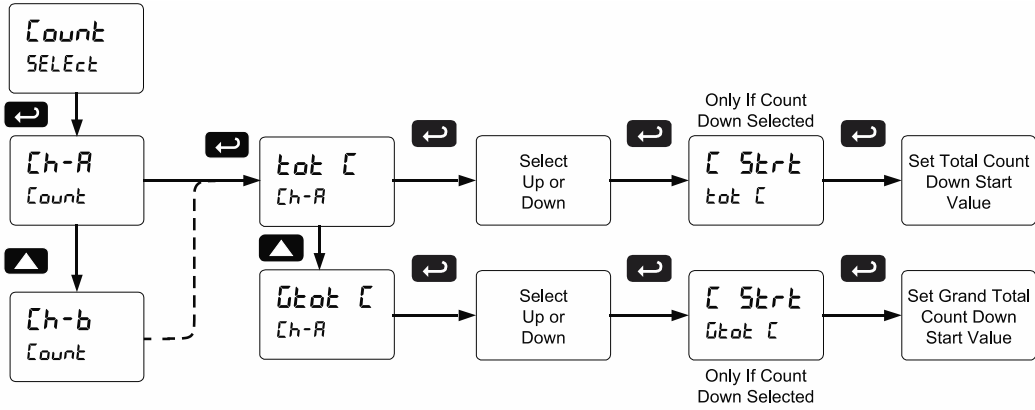

Analog Output Programming (RoutPr)

The *Analog Output Programming* menu is used to program the behavior of the 4-20 mA output. The following parameters and functions are programmed in this menu:

1. Source: Source for generating the 4-20 mA output
2. Overrange: Analog output value with display in overrange condition
3. Underrange: Analog output value with display in underrange condition
4. Break: Analog output value when loop break is detected
5. Max: Maximum analog output value allowed regardless of input
6. Min: Minimum analog output value allowed regardless of input

Analog Output Source

The analog output source can be based on either of the input channel rate, total, or grand totals (Ch-A, Ch-B), the math channel (Ch-C), maximum stored value of either input channel (Hi-A, Hi-B), minimum stored value of either input channel (Lo-A, Lo-B), relay set points, or the Modbus input.

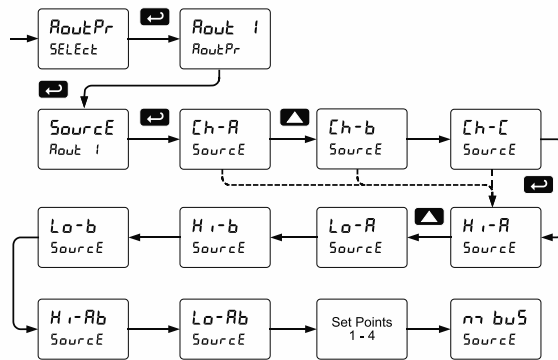

To base an analog output on the rate, total, or grand total of channels A or B, select the channel in the *Analog Output Source* menu. Then select the rate, total, or grand total as the source reference for the output, and program the output scale.

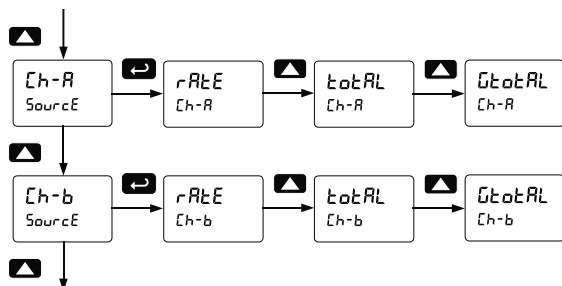

Analog Output Value for Loss of 4-20 mA Input (Loop Break)

The AoutPr - Break menu is used to force the analog output to go to a user-specified mA value if a break condition is detected in the 4-20 mA input loop. Selecting Ignore causes the mA output to go to the minimum value.

Analog Output Calibration

To perform the analog output calibration, it's recommended to use a milliamp totalizer with a resolution of at least 0.1 µA to measure the output current. The values saved internally during this procedure are used for scaling the 4-20 mA output in the *Setup* menu.

Analog Output Calibration Procedure

1. Wire the PD8-6262 4-20 mA output to a current loop that includes a power supply (internal or external 12 to 24 VDC), and the mA input on the digital totalizer. See *Figure 18. 4-20 mA Output Connections* on page 27 for details.
2. Turn on all devices. Allow for a 15 to 30 minute warm-up.
3. Go to the Advanced Features menu, navigate to Select (SELEct) and choose Analog Output Programming (RoutPr)/Calibration (CALIB) menu and press **Enter**.
4. The display will show 4.000. The PD8-6262 mA output should now be close to 4 mA. Press Enter and the display will show 04.000. Enter the actual value read by the digital mA totalizer and press **Enter**.
5. The display will show 20.000. The PD8-6262 mA output should now be close to 20 mA. Press **Enter** and the display will show 20.000. Enter the actual value read by the digital mA totalizer and press **Enter**.
6. The totalizer will now calculate the calibration factors and store them.
7. Press **Menu** to exit and return to Run mode.

Programmable Function Keys User Menu (uSEr)

The *User* menu allows the user to assign the programming buttons function keys F1, F2, and F3, the digital input F4 (located on the input signal connector), and four digital inputs (located on the digital I/O connector) to access most of the menus or to activate certain functions immediately (e.g. reset totals, reset max & min, hold relay states, etc.). This allows the totalizer to be greatly customized for use in specialized applications.

The four digital outputs can be assigned to a number of actions and functions executed by the totalizer (i.e. alarms, relay acknowledgement, reset totals, reset max, min, or max & min, tare, and reset tare). The digital outputs can be used to trigger external alarms or lights to indicate these specific events.

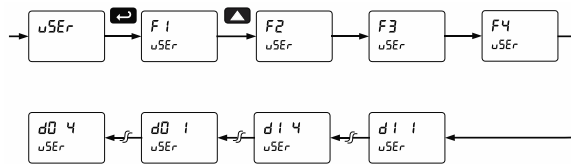

Function Keys & Digital I/O Available Settings

Refer to the following table for descriptions of each available function key or digital I/O setting.

Function Keys & Digital I/O Available Settings	
Display	Description
r S t H i	Reset the stored maximum display values for all channels
r S t L o	Reset the stored minimum display values for all channels
r S t H L	Reset the stored maximum & minimum display values for all channels
r E L R Y	Directly access the relay menu
S E t i	Directly access the set point menu for relay 1 (*through 4)
r L Y d	Disable all relays until a button assigned to <i>enable relays (r L Y E)</i> is pressed
r L Y E	Enable all relays to function as they have been programmed
d H o l d	Hold current relay states and analog output as they are until a button assigned to <i>enable relays (r L Y E)</i> is pressed
d H o l d	Hold the current display value, relay states, and analog output momentarily while the function key or digital input is active. The process value will continue to be calculated in the background.
d R b c	Scrolls values for A, B & C when activated. Keeps the last value for 10 seconds and then it returns to its assignment. Values are displayed on display line 1 and the corresponding channel and units on display line 2.
d t o t	Scrolls through totals for channels A, B, and C (which is the sum of A and B). Values are displayed on display line 1.
d G r a n d t o t	Scrolls through grand totals for channels A, B, and C (which is the sum of A and B). Values are displayed on display line 1.
L n i H i	Display maximum channel A display value on line 1
L n i L o	Display minimum channel A display value on line 1
L n i H L	Display maximum & minimum channel A display values on line 1
L n 2 H i	Display maximum channel B display value on line 2
L n 2 L o	Display minimum Channel B display value on line 2
L n 2 H L	Display maximum & minimum channel B display values on line 2

Function Keys & Digital I/O Available Settings	
Display	Description
L n 2 H L	Display minimum channel C display value on line 2
L n 2 H L	Display maximum & minimum channel C display values on line 2
L n 2 H L	Display maximum channel C display value on line 2
F o n i	Force relay 1 (*through 4) into the on state. This function is used in conjunction with a digital input to achieve interlock functionality. See <i>Setting Up the Interlock Relay (Force On) Feature</i> page 49 for details about interlock relays.
C o n t r l	Directly access the Manual Control menu
d i s a b l e	Disable the selected function key or digital I/O
R c k	Acknowledge all active relays that are in a manual operation mode such as auto-manual or latching
r E S E t	Directly access the reset menu
r S t t	Reset totals for all channels
r S t G r	Reset grand totals for all channels
r S t t A	Reset total for channel A
r S t G r A	Reset grand total for channel A
r S t t B	Reset total for channel B
r S t G r B	Reset grand total for channel B
m i m i c	Mimic the menu button functionality (digital inputs only)
r i g h t a r r o w	Mimic the right arrow/F1 button functionality (digital inputs only)
u p a r r o w	Mimic the up arrow/F2 button functionality (digital inputs only)
e n t e r	Mimic the enter/F3 button functionality (digital inputs only)
A l a r m i	Provide indication when alarm 1 (*through 4) has been triggered (digital outputs only)

Internal Calibration (ICRL)

The totalizer is **factory calibrated** prior to shipment for milliamps and volts with calibration equipment that is certified to NIST standards.

The use of calibrated signal sources is necessary to perform the internal calibration of the totalizer. Check calibration of the totalizer at least every 12 months. Each input and input type must be recalibrated separately.

Notes:

1. If totalizer is in operation and it is intended to accept only one input type (e.g. 4-20 mA), recalibration of other input is not necessary.
2. Allow the totalizer to warm up for at least 15 minutes before performing the internal calibration procedure.

The *Internal calibration* menu is part of the *Advanced Features* menu.

1. Press and hold the Menu button for three seconds to access the advanced features of the totalizer.
2. Press the Up arrow button to scroll to the *Internal calibration* menu (ICRL) and press Enter.
3. Select channel A (Ch-R) or channel B (Ch-b) and press enter.
4. The totalizer displays either current calibration (ICRL) or voltage calibration (IVRL), according to the input setup. Press Enter to start the calibration process.

Example of Internal Calibration for current input:

5. The totalizer displays *low* input current message (CLo). Apply the low input signal and press Enter. The display flashes for a moment while the totalizer is accepting the low input signal.
6. After the display stops flashing, a number is displayed with the leftmost digit brighter than the rest. The bright digit is the active digit that can be changed by pressing the Up arrow button. Press the Right arrow button to move to the next digit.
7. Set the display value to correspond to the input signal being calibrated, typically 4.000 mA.
8. The display moves to the *high* input calibration (CHi). Apply the high input signal and press Enter.
9. Set the display for the high input calibration, in the same way as it was set for the low input calibration, typically 20.000 mA.

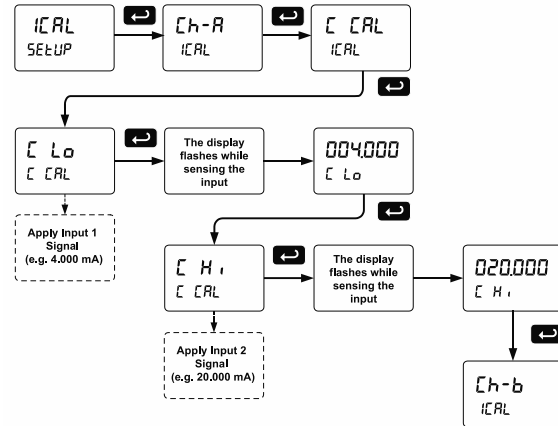

The graphic above shows the calibration of the current input. The voltage input is calibrated in a similar way.

Tips:

- Low and high input signals can be any valid values within the range of the totalizer.
- Observe minimum input span requirements between input 1 and input 2.
- Low input should be less than high input signal.

Error Message (Error)

An error message indicates that the calibration or scaling process was not successful.

After the error message is displayed, the totalizer reverts to input 2 during calibration or scaling and to input 1 during internal calibration, allowing the appropriate input signal to be applied or programmed.

The error message might be caused by any of the following conditions:

1. Input signal is not connected to the proper terminals, or it is connected backwards.
2. Wrong signal selection in *Setup* menu.
3. Minimum input span requirements not maintained.

Minimum Input Span

The minimum input span is the minimum difference between input 1 and input 2 signals required to complete the calibration or scaling of the totalizer.

Input Range	Input 1 & Input 2 Span
4-20 mA	0.15 mA
±10 VDC	0.10 VDC

Totalizer Operation

When installed, the primary way to operate the totalizer is with the SafeTouch through-glass buttons that allow the user to perform various operations without removing the cover and exposing the electronics to the hazardous environment. The user can also operate the totalizer by connecting a suitable control station or switch to one of the digital inputs that can be used to perform various operations on the totalizer based on the Programmable Function Keys. Finally, certain operations can be performed on the totalizer with MeterView Pro software or through Modbus commands.









The two default operations that can be performed with the totalizer's SafeTouch buttons are:

1. Display the maximum and minimum readings
2. Acknowledge the relays

In addition, the user can program the SafeTouch Buttons to perform a variety of useful operations by reassigning them to other functions per *Function Keys & Digital I/O Available Settings* on page 60.

Button Operation

The following table shows the default operations for the F1, F2, and F3 SafeTouch Buttons, Displaying and resetting the maximum and minimum values and resetting the relays:

Button Symbol	Description
 	Press to enter or exit Programming Mode, view settings, or exit max/min readings
 	Press to reset max/min readings or other parameter/function assigned through the <i>User</i> menu
 	Press to display max/min readings or other parameter/function assigned through the <i>User</i> menu
 	Press to acknowledge relays or other parameters/function assigned through the <i>User</i> menu



To learn more about SafeTouch buttons, see this video:

predig.com/videos/Safetouch_Buttons

SafeTouch Buttons

The ProtEX-MAX is equipped with four sensors that operate as through-glass buttons so that it can be programmed and operated without removing the cover (and exposing the electronics) in a hazardous area.

These buttons can be disabled for security by selecting DISABLE on the switch labeled NO-CONTACT BUTTONS located on the connector board.



To actuate a button, press one finger to the glass directly over the marked button area. Then retract finger more than three inches from the glass before pressing the next button. When the cover is removed, the four mechanical buttons located next to the sensors are used. The sensors are disabled when a mechanical button is pressed and will automatically be re-enabled after 60 seconds of inactivity. The SafeTouch Buttons are designed to filter normal levels of ambient interference and to protect against false triggering, however, it is recommended that the SafeTouch Buttons be disabled (slide switch to DISABLE) if there is an infrared interference source in line-of-sight to the display.

The SafeTouch Buttons are configured by default to duplicate the function of the front panel mechanical pushbuttons associated with the integrated totalizer. The symbols by each SafeTouch button correspond to a mechanical button as shown in the table to the left.

SafeTouch Button Tips:

- To the extent possible, install the display facing away from sunlight, windows, reflective objects, and any sources of infrared interference.
- Keep the glass window clean.
- Tighten the cover securely.
- Use a password to prevent tampering.

Function Keys Operation

During operation, the programmable function keys operate according to the way they have been programmed in the *Advanced Features – User menu*. See *Programmable Function Keys User Menu (u5Er)* on page 59 for details.

The table on page 62 shows the factory default settings for F1, F2, and F3.

Digital Inputs Operation

Five (5) digital inputs, F4, DI-1 to DI-4, come standard on the totalizer. These digital inputs are programmed identically to function keys F1, F2, and F3. The inputs are triggered with a contact closure to +5 V in the case of digital inputs 1-4 or with an active high signal, see *Digital Inputs Operation* on page 63 for details. The F4 is triggered with a contact closure to COM or with an active low signal. During operation, digital inputs operate according to the way they are programmed in the *Advanced Features – User menu*. See *Programmable Function Keys User Menu (u5Er)* on page 59 for details.

Maximum/Minimum Readings

The max & min readings (peak & valley) reached by the process can be displayed either continuously or momentary:

1. Display briefly by assigning to the F1-F3 function keys or to the digital inputs in the *User menu*.
2. Display continuously by assigning either display to max/min through the *Display menu*.

Any of the F1-F3 function keys (buttons) and the digital inputs can be programmed to reset the max & min readings. The totalizers are set at the factory to display the max/min reading by pressing the Up arrow/F2 button and to use the Right arrow/F1 button to reset the max/min.

To display max and min channel A reading using function key with factory defaults:

1. Press Up arrow/F2 button to display minimum reading of channel A since the last reset/power-up. The display will then display the maximum reading of channel A since the last reset/power-up.
2. To reset max/min press Right arrow/F1 button. The max & min displays are reset to actual values.
3. Press Menu to exit max/min display reading.

Total Reset Capabilities

The user may reset the total via a SafeTouch button, the F4 terminal at the back of the meter, an external contact closure on the digital inputs, automatically via user selectable preset value and time delay, or through serial communications.

Total Reset via SafeTouch Button

The three through-glass SafeTouch button function keys can be programmed to reset the total and grand total. This makes it possible for the user to reset either the total or the grand total without opening the enclosure cover and without the need for external devices. Of course, if the total or grand total is password protected, they will not reset when the function key is pressed.



Total Reset via F4 Terminal

The PD8-6262 includes a digital input (referred to as the F4 terminal) located on the back of the electronics module as standard that can be used to reset the total or grand total, among other things. This is the preferred method for externally resetting the total or grand total because it does not interfere with the operation of the SafeTouch buttons for programming as described below in the Total Reset via Digital Input section.

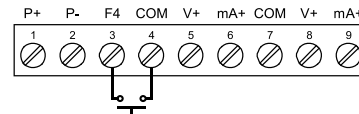

Total Reset via Digital Input

In addition to the F4 digital input described above, the PD8-6262 also includes four digital inputs that can be used to reset the total or grand total. However, if a digital input is used to reset the total, or for some other purpose, the corresponding through-glass SafeTouch button will function as a programming key.

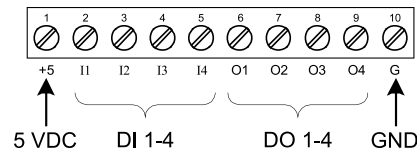

Total Reset via Preset Value

The total and grand total can be programmed for automatic reset based on a preset value determined by the user. In the automatic reset mode, a programmable time delay is available to reset the total or grand total after the assigned preset is reached.

Total Reset via Serial Communications

The total and grand total can be reset via serial communications such as a Modbus command or MeterView Pro.

Troubleshooting

The rugged design and the user-friendly interface of the totalizer should make it unusual for the installer or operator to refer to this section of the manual. However, due to the many features and functions of the totalizer, it's possible that the setup of the totalizer does not agree with what an operator expects to see. If the totalizer is not working as expected, refer to the *Diagnostics* menu and recommendations below.

Diagnostics Menu (d ,RŁ)

The *Diagnostics* menu is located in the *Advanced Features* menu. To access the *Diagnostics* menu, see *Advanced Features Menu* on page 52.

This menu allows the user to test the functionality of all the totalizer LEDs, check the totalizer's software and version information, and erase the MeterView Pro software installation files from the totalizer. Press the Enter button to view the settings and the Menu button to exit at any time.

For a description of the diagnostic messages, see *Advanced Features Menu & Display Messages* on page 52.

Testing the Display LEDs

To test all LEDs on the display:

1. Go to the *Diagnostics* menu (d ,RŁ) and press Enter button.
2. Press Up arrow button and scroll to *LED Test* menu (ŁŁŁ Ł)
3. Press the Enter button to activate the LED Test. The totalizer will cycle through all digits, decimal points, and relay indicators to enable the operator to check that all LEDs are functioning properly.
4. Press the Enter button again to access the *Information* menu (,nFŁ) or press the Menu button to return to Run Mode.

Determining Software Version

To determine the software version of a totalizer:

1. Go to the *Diagnostics* menu (d ,RŁ) and press Enter button.
2. Press Up arrow button and scroll to *Information* menu (,nFŁ).
3. Press Enter to access the software number (5FŁ) and version (ŁŁŁŁ) information. Write down the information as it is displayed. Continue pressing Enter until all the information is displayed.
4. The totalizer returns to Run Mode after displaying all the settings.

Reset Totalizer to Factory Defaults

When the parameters have been changed in a way that is difficult to determine what's happening, it might be better to start the setup process from the factory defaults.

Instructions to load factory defaults:

1. Enter the *Advanced Features* menu. See *Advanced Features Menu*, page 52.
2. Press Up arrow to go to *Diagnostics* menu
3. Press and hold Right arrow for three seconds, press Enter when display flashes r E5EŁ.
Note: If Enter is not pressed within three seconds, the display returns to Run Mode.
4. The totalizer goes through an initialization sequence (similar as on power-up), and loads the factory default settings.

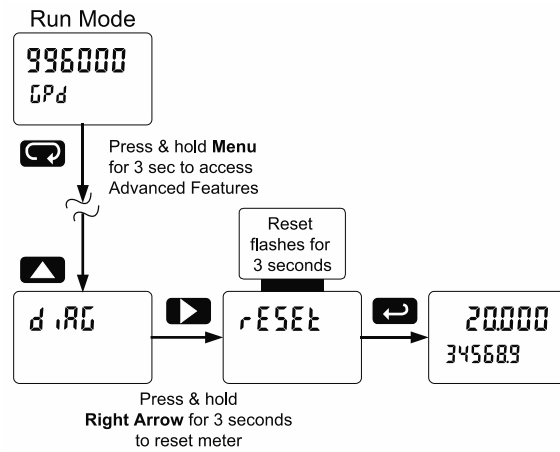

Factory Defaults & User Settings

The following table shows the factory setting for most of the programmable parameters on the totalizer.

Factory Defaults & User Settings		
Parameter	Display	Default Setting
Input type	InP _{ut}	
Input type, channel A	[h-R]	4-20 mA
Input type, channel B	[h-b]	4-20 mA
Total, channel A	[h-R]	Yes
Total, channel B	[h-b]	Yes
Units	un _{its}	
Rate unit, channel A	[h-R]	mA-A
Rate unit, channel B	[h-b]	mA-b
Unit, channel C	[h-[]	mA-C
Total unit, channel A	tot-R	tot-A
Grand total unit, ch-A	gtot-R	Gtot-A
Total unit, channel B	tot-b	tot-b
Grand total unit, ch-B	gtot-b	Gtot-B
Decimal Point	dEc _{Pt}	
Rate, channel A	rRtE	3
Total, channel A	totRL	1
Grand total, channel A	gtotRL	0
Rate, channel B	rRtE	3
Total, channel B	totRL	1
Grand total, channel B	gtotRL	0
Channel C	[h-[]	3
Number of points	no _{PtS}	
Number of points, ch A	[h-R]	2
Number of points, ch B	[h-b]	2
Scaling, (channel A)	ScRL _R	
Input 1, channel A	InP ₁	4.000 mA
Display 1, channel A	d _{1S} ₁	4.000
Input 2, channel A	InP ₂	20.000 mA
Display 2, channel A	d _{1S} ₂	20.000
Scaling (channel B)	ScRL _b	
Input 1, channel B	InP ₁	4.000 mA
Display 1, channel B	d _{1S} ₁	4.000
Input 2, channel B	InP ₂	20.000 mA
Display 2, channel B	d _{1S} ₂	20.000
Total setup	tSEt _{uP}	
Time base, channel A	tbRSE	Sec
Total conversion factor, Ch-A	t [F	1.000
Grand total conversion factor, Ch-A	gt [F	1.000
Time base, channel B	tbRSE	Sec

Factory Defaults & User Settings		
Parameter	Display	Default Setting
Total conversion factor, Ch-B	t [F	1.000
Grand total conversion factor, Ch-B	gt [F	1.000
Total reset	trESEt	
Total reset, channel A	t rSt	Manual
Grand total reset, Ch-A	gt rSt	Manual
Total reset, channel B	t rSt	Manual
Grand total reset, Ch-B	gt rSt	Manual
Display assignment	dSPLR _Y	
Display line 1	d [h-R	Channel A
Display line 2	d [h-b	Channel B
Display intensity	d- _{int} _{ty}	6
Relay	rELR _Y	
Relay 1 assignment	[h-R	Channel A total
Relay 1 action	Rct 1	Automatic
Relay 1 set point	SEt 1	100.0
Relay 2 assignment	[h-R	Channel A total
Relay 2 action	Rct 2	Automatic
Relay 2 set point	SEt 2	200.0
Relay 3 assignment	[h-R	Channel A rate
Relay 3 action	Rct 3	Automatic
Relay 3 set point	SEt 3	3.000
Relay 3 reset point	rSt 3	2.500
Relay 4 assignment	[h-R	Channel A rate
Relay 4 action	Rct 4	Automatic
Relay 4 set point	SEt 4	4.000
Relay 4 reset point	rSt 4	3.500
Fail-safe relay 1 to 4	FLS 1	Off
On delay relay 1 to 4	On 1	0.0 sec
Off delay relay 1 to 4	OFF 1	0.0 sec
Loop break relay 1 to 4	ignorE	Ignore
Analog output	Rout	
Display 1 analog out	d _{1S} ₁	4.000
Output 1 value	out 1	4.000 mA
Display 2 analog out	d _{1S} ₂	20.000
Output 2 value	out 2	20.000 mA
Source analog output	Source	Channel A
Overrange output	o- _r RnG	21.000 mA
Underrange output	u- _r RnG	3.000 mA
Loop break output	brERH	3.000 mA
Maximum output	n _{max}	23.000 mA
Minimum output	n _{min}	3.000 mA
Filter	F _{ILT} _{Er}	

Factory Defaults & User Settings		
Parameter	Display	Default Setting
Filter, channel A	[h-R	70
Filter, channel B	[h-b	70
Bypass, channel A	bYPR55	0.2
Bypass, channel B	bYPR55	0.2
Round	r ound	1
Cutoff	[u toFF	
Cutoff value, channel A	[h-R	0.0 (disabled)
Cutoff value, channel B	[h-b	0.0 (disabled)
Serial	SEr RL	
Slave ID (Address)	SLRU Id	247
Baud rate	bRud	9600
Transmit delay	tr dLY	50 ms
Parity	PRr itY	Even
Byte-to-byte timeout	t -bYt	010 (0.1 sec)
Math	n rRt h	
Math, channel C	Sun r	Sum
Adder (constant P)	RddEr	0.000
Factor (constant F)	FRct or	1.000
User	uSEr	
F1 function key	F 1	Reset max & min
F2 function key	F 2	Line 1 Max & Min
F3 function key	F 3	Acknowledge relays
F4 function (digital input)	F 4	Acknowledge relays
Digital input 1	d i 1	Menu
Digital input 2	d i 2	Right arrow
Digital input 3	d i 3	Up arrow
Digital input 4	d i 4	Enter
Digital output 1	dO 1	Alarm 1
Digital output 2	dO 2	Alarm 2
Digital output 3	dO 3	Alarm 3
Digital output 4	dO 4	Alarm 4
Password	PR55	
Password 1	PR55 1	000000 (unlocked)
Password 2	PR55 2	000000 (unlocked)
Password 3	PR55 3	000000 (unlocked)
Total	t o t RL	000000 (unlocked)
Grand total	G t o t RL	000000 (unlocked)

Troubleshooting Tips

This totalizer is a highly sophisticated instrument with an extensive list of features and capabilities. If the front panel buttons are used to program the totalizer, it may be a difficult task to keep everything straight. That is why we strongly recommend the use of the free [MeterView Pro](#) software for all programming activities. A USB cable is provided with the totalizer for programming with MeterView Pro software.

If you have programmed the totalizer with the front panel buttons and it is not working as intended, try re-programming the totalizer using MeterView Pro software.

Symptom	Check/Action
No display at all	Check power at power connector
Not able to change setup or programming, L o c d is displayed	Totalizer is password-protected, enter correct six-digit password to unlock
Totalizer does not respond to input change	If a <i>Low-Flow Cutoff Value</i> has been programmed, the totalizer will display zero below that point, regardless of the input – which can appear like the totalizer is not responding to an input change. Check to make sure the problem is not being caused by an undesired low-flow cutoff value. To prevent the display from showing a negative value, set the low-flow cutoff to a value greater than zero.
Totalizer displays error message during calibration (Error)	Check: <ol style="list-style-type: none"> 1. Signal connections 2. Input selected in <i>Setup</i> menu 3. Minimum input span requirements
Totalizer displays <ol style="list-style-type: none"> 1. 999999 2. -999999 	Check: <ol style="list-style-type: none"> 1. Input selected in <i>Setup</i> menu 2. Corresponding signal at Signal connector
Display is unstable	Check: <ol style="list-style-type: none"> 1. Input signal stability and value 2. Display scaling vs. input signal 3. Filter and bypass values (increase)
Display response is too slow	Check filter and bypass values
Display reading is not accurate	Check: <ol style="list-style-type: none"> 1. Input signal conditioner selected: Linear, square root, etc. 2. Scaling or calibration
Display does not respond to input changes, reading a fixed number	Check: <ol style="list-style-type: none"> 1. Display assignment, it might be displaying max, min, or set point.
Display alternates between <ol style="list-style-type: none"> 1. H i and a number 2. L o and a number 	Press Menu to exit max/min display readings.
Relay operation is reversed	Check: <ol style="list-style-type: none"> 1. Fail-safe in <i>Setup</i> menu 2. Wiring of relay contacts
Relay and status LED do not respond to signal	Check: <ol style="list-style-type: none"> 1. Relay action in <i>Setup</i> menu 2. Set and reset points
Flashing relay status LEDs	Relays in manual control mode or relay interlock switches opened.
Totalizer not communicating with application programs	Check: <ol style="list-style-type: none"> 1. Serial adapter and cable 2. Serial settings 3. Meter address and baud rate
If the display locks up or the totalizer does not respond at all	Cycle the power to reboot the microprocessor.

Troubleshooting Tips

Symptom	Check/Action
SafeTouch buttons do not respond	<ol style="list-style-type: none"> 1. If mechanical button was pushed, the SafeTouch buttons will be re-enabled automatically 60 seconds after the last button push. 2. If slide switch on connector board is in DISABLE position, switch to ENABLE. 3. Strong direct sunlight may interfere with SafeTouch button operation. It is recommended to operate the buttons by standing so as to block direct sunlight.
Serial Communications METER LED Indicator is off	Check: <ol style="list-style-type: none"> 1. Modular cable connection 2. Power to the device
If only the TX (or DATA IN) data status LED is flashing when serial communications attempted	Check: <ol style="list-style-type: none"> 1. Serial cable 2. Instrument address & baud rate 3. Program address & baud rate
If both data status LEDs (TX and RX) are off when trying to communicate	Remove all unnecessary cables and instruments from the bus. Try getting the system to work with only one device (to ease troubleshooting) and then expand the system one device at a time.
Communications slow	Increase the baud rate
Random communication errors	<ol style="list-style-type: none"> 1. Increase the TX delay time 2. Decrease the baud rate
Other symptoms not described above	Call Technical Support for assistance.

Note: Certain sequences of events can cause unexpected results. To solve these issues, it is best to start fresh from factory defaults and use the manual as a step by step programming guide, rather than a random approach to programming. To reset the totalizer to factory defaults, see *Reset Totalizer to Factory Defaults* on page 64. In addition, for best results, we recommend using the free MeterView Pro software for all programming needs.

Complete Product Line of Displays and Controllers IN ALL SHAPES, SIZES & LOCATIONS



Big, Bright Displays
For Indoor or Outdoor
in Bright Sunlight



Large Dual-Line
6-Digit Display



24 VDC
Transmitter
Power Supply



MeterView® Pro USB
Programming Software



Universal 85-265
VAC or 12-24 VDC
Input Power
Options



4-20 mA, 0-10 V,
Thermocouple, RTD,
Strain Gauge, High
Voltage, & Modbus Inputs



Up To Four
3 A Form C
Relays (SPDT)



EXPLOSION-PROOF ProtEX-MAX Series

- NEMA 4X, IP68 Rated Enclosure
- SafeTouch® Through-Glass Buttons
- Operating Temperature of -40 to 65°C
- Worldwide Approvals

LARGE DISPLAYS Helios Series

- 1.8" Digits Readable From 100 Feet
- NEMA 4X, IP65 Rated Enclosure
- Operating Temperature of -40 to 65°C
- Now UL and C-UL Approved!



PANEL METERS ProVu Series

- NEMA 4X, IP65 Rated Front
- Programmable Function Keys
- UL, C-UL, and CE Approvals
- 1/8 DIN Size

Go to PREDIG.COM for details on ProVu, ProtEX-MAX and Helios Series Meters

Contact Precision Digital

Technical Support

Call: (800) 610-5239 or (508) 655-7300

Fax: (508) 655-8990

Email: support@predig.com

Sales Support

Call: (800) 343-1001 or (508) 655-7300

Fax: (508) 655-8990

Email: sales@predig.com

Place Orders

Email: orders@predig.com

For the latest version of this manual please visit

www.predig.com

PRECISION DIGITAL CORPORATION

233 South Street • Hopkinton MA 01748 USA
Tel (800) 343-1001 • Fax (508) 655-8990

www.predig.com

