

PD8-6310-WM Explosion-Proof NTEP Certified Pulse Input Batch Controller

Instruction Manual



IECEX



MeterView Pro

USB Install

- Fully-Approved Explosion-Proof Batch Controllers
- NTEP Certified Weighing and Measuring Device
- Mechanically Secured Programming Lockout
- Pulse, Open Collector, NPN, PNP, TTL, Switch Contact, Sine Wave (Coil), Square Wave Inputs
- Dual-Line 6-Digit Display, 0.6" (15 mm) & 0.46" (12 mm)
- SafeTouch Through-Glass Button Programming
- Display Mountable at 0°, 90°, 180°, & 270°
- Isolated 5, 10 or 24 VDC Flowmeter Power Supply
- Gate Function for Rate Display of Slow Pulse Rates
- 4 Relays with Interlocking Capability + Isolated 4-20 mA Output
- Free PC-Based, On-Board, MeterView Pro USB Programming Software
- SunBright Display Standard Feature; Great for Outdoor Applications
- Start / Pause / Stop, Change Batch with Front Panel Buttons
- Display Batch Total, Rate, Grand Total, Count or Preset
- Single or Multi-Stage Batch Control (Up to 4 Relays)
- Front Panel or Remote Total Reset
- Automatic Ovrerrun Correction
- Automatic or Manual Batch Control
- Low or High Flow Alarms while Batching
- K-Factor, Internal Scaling, or External Calibration
- Operating Temperature Range: -40 to 60°C (-40 to 140°F)
- FM Approved as Explosion-Proof / Dust-Ignition-Proof / Flame-Proof
- CSA Certified as Explosion-Proof / Dust-Ignition-Proof / Flame-Proof
- ATEX and IECEx Certified as Flame-Proof
- Input Power Options: 85-265 VAC / 90-265 VDC or 12-24 VDC / 12-24 VAC
- Programmable Display, Function Keys & Digital Inputs
- Flanges for Wall or Pipe Mounting
- Explosion-Proof, IP68, NEMA 4X Die-Cast Aluminum Enclosure
- On-Board RS-485 Serial Communications
- Modbus RTU Communication Protocol Standard
- Password Protection
- Four 3/4" NPT Threaded Conduit Openings (Two Plugs Installed)
- 3-Year Warranty

PRECISION DIGITAL CORPORATION

233 South Street • Hopkinton MA 01748 USA

Tel (800) 343-1001 • Fax (508) 655-8990

www.prediq.com

PRECISION
DIGITAL

The Complete **ProtEX™** Series

MAX



PD8-154
**4-Point Alarm
Annunciator**



PD8-6100
Strain Gauge Meter



PD8-158
**8-Point Alarm
Annunciator**



PD8-6200
**Analog Input
Flow Rate/Totalizer**



PD8-765
**Process &
Temperature Meter**



PD8-6210
**Analog Input Batch
Controller**



PD8-6000
Process Meter



PD8-6262
**Analog Dual-Input
Flow Rate/Totalizer**



PD8-6001
**Feet & Inches
Level Meter**



PD8-6300
**Pulse Input
Flow Rate/Totalizer**



PD8-6060
**Dual-Input
Process Meter**



PD8-6310
**Pulse Input
Batch Controller**



PD8-6080
**Modbus® Scanner
with Dual Analog Input**



PD8-6363
**Pulse Dual-Input
Flow Rate/Totalizer**



PD8-6081
**Feet & Inches
Modbus® Scanner**



PD8-7000
Temperature Meter

Go to PREDIG.COM for details on the entire ProtEX-MAX Series Meters

Disclaimer

The information contained in this document is subject to change without notice. Precision Digital makes no representations or warranties with respect to the contents hereof and specifically disclaims any implied warranties of merchantability or fitness for a particular purpose. See Warranty Information and Terms & Conditions on www.prediq.com for complete details.

CAUTION

- Read complete instructions prior to installation and operation of the controller.

WARNINGS

- Risk of electric shock or personal injury.
- This product is not recommended for life support applications or applications where malfunctioning could result in personal injury or property loss. Anyone using this product for such applications does so at his/her own risk. Precision Digital Corporation shall not be held liable for damages resulting from such improper use.
- Failure to follow installation guidelines could result in death or serious injury. Make sure only qualified personnel perform the installation.
- Never remove the controller cover in explosive environments when the circuit is live.
- Cover must be fully engaged to meet explosion-proof/dust-ignition-proof/flame-proof requirements.

WARNING
Cancer and Reproductive Harm - www.P65Warnings.ca.gov

Limited Warranty

Precision Digital Corporation warrants this product against defects in material or workmanship for the specified period under "Specifications" from the date of shipment from the factory. Precision Digital's liability under this limited warranty shall not exceed the purchase value, repair, or replacement of the defective unit. See Warranty Information and Terms & Conditions on www.prediq.com for complete details.

Registered Trademarks

All trademarks mentioned in this document are the property of their respective owners.

© 2022 Precision Digital Corporation.
All rights reserved.

FREE MeterView Pro Programming Software



The controller can be powered from the USB connection. When using the USB connection, **DO NOT** apply AC or DC power to the controller.

The easiest and quickest way to program your ProtEX-MAX batch controller is to use the FREE MeterView Pro programming software. This software is loaded into the controller and connects and installs directly to your PC with a USB cable. We recommend that the first thing you do after taking the controller out of the box is connect the ProtEX-MAX to your PC with the provided USB cable – do not use a different cable. **DO NOT** apply AC or DC power to the controller while your PC is connected to the controller as it will disrupt the USB connection. You don't even have to apply an input signal.

MeterView Pro programming software is intuitive, and most customers can get their controller programmed as they like without even looking in the manual.

Watch MeterView Pro Software Video at
www.prediq.com/meterviewpro

In addition to programming, the software may be used to perform many useful tasks:

- Start, Pause, Stop the batch
- Change preset & pre-close settings
- Reset total & grand total
- Test the relays functionality
- Monitor the batch process
- Datalogging using your PC
- Generate & save program files for later use

Once your controller is programmed the way you want it, you can wire it up for your application per the instructions in this manual and install it. If you find that you need to make adjustments to the programming after the controller is installed, you can use the programming buttons and the instructions in this manual to do so.

WARNING

- When using the USB connection, the controller should only be connected to a computer when both devices are in a non-hazardous area.

Table of Contents

Introduction.....	7
Ordering Information.....	7
Key Features.....	9
Specifications	14
General.....	14
Batch Controller Rate/Totalizer Display	15
Pulse Inputs.....	16
Relays.....	16
USB Connection.....	16
Isolated 4-20 mA Transmitter Output	17
RS-485 Serial Communications	17
Modbus® RTU Serial Communications.....	17
Digital Input (F4).....	17
Digital Inputs & Outputs	17
MeterView Pro Software	17
Compliance Information.....	18
NTEP Certification.....	18
Electromagnetic Compatibility.....	18
Product Ratings and Approvals.....	18
EU Declaration of Conformity.....	19
Safety Information	19
Installation.....	19
Unpacking.....	19
Mounting	20
Wall Mounting Instructions	20
Installation Overview	22
MeterView Pro Software	22
Controller Supply Voltage Selection (P+, P-).....	23
Programming Lockout Jumper (NTEP Lockout)	23
Wire Security Seal Installation (NTEP Seal).....	24
Connections	25
Required & Factory Wired Connection.....	25
ProVu Electronics Module Layout	26
USB Connection	26
Power Connections.....	27
Pulse Signal Connections	28
Relay Connections.....	29
Interlock Relay Feature	29
Switching Inductive Loads.....	29
RS-485 Connections.....	30
RS-485 Multi-Drop Connection	30
Digital I/O Connections	30
F4 Digital Input Connections.....	30
4-20 mA Output Connections.....	31
Analog Output Transmitter Power Supply.....	31
Remote Programming.....	31
Setup and Programming.....	32
Overview	32
LED Status Indicators	32
Programming Buttons	33
SafeTouch Buttons	33
Display Functions and Messages.....	34
Main Menu.....	36
Setting Numeric Values	36
Setting Up the Batch Controller (SEtUP).....	37
Setting the Input Signal (InPUt).....	38
Setting the Totalizer & Batch Control Features (tOtAL).....	38
Setting the Input Units or Custom Tags (unItS).....	38
Setting the Decimal Point (dEc Pnt)	39
Programming the Batch Controller (PrOg).....	39
Setting the Display Parameter & Intensity (dSPLY)	42
Display Intensity (d-IntY).....	42

- Setting the Relay Operation (rELRY)..... 43**
 - Relay Assignment (R55 iLn)..... 44
 - Setting the Relay Action..... 45
 - Setting Batch Control Relays 45
 - Programming Alarm Set and Reset Points..... 45
 - Setting Fail-Safe Operation..... 45
 - Programming Time Delay 45
 - Automatic Batch Control Operation..... 46
- Relay and Alarm Operation Diagrams 47**
 - High Alarm Operation (Set > Reset) 47
 - Low Alarm Operation (Set < Reset) 47
 - High Alarm with Fail-Safe Operation (Set > Reset)..... 47
 - Low Alarm with Fail-Safe Operation (Set < Reset)..... 47
 - Time Delay Operation 48
 - Total Relay Sampling Operation 48
- Relay Operation Details 49**
 - Overview 49
 - Relays Initialization 49
 - Fail-Safe Operation..... 49
 - Front Panel LEDs..... 49
 - Automatic Reset (Ruto) 49
 - Pump Alternation Control..... 49
 - Sample Relay Operation..... 50
 - Setting Up the Interlock Relay (Force On) Feature 50
- Scaling the 4-20 mA Analog Output (Rout) 51**
- Reset Menu (rESEt)..... 51**
- Manual Control Menu (Control) 51**
- Setting Up the Password (PR55)..... 52**
 - Protecting or Locking the Controller 52
 - Grand Total Reset Password & Non-Resettable Total..... 52
 - Making Changes to a Password Protected Controller..... 52
 - Disabling Password Protection 52
- Controller Operation 53**
 - Button Operation..... 53**
 - SafeTouch Buttons 53**
 - Default Batch Control Operation..... 54**
 - Batch Control Operation Example..... 54**
 - Manual Batch Control 55**
 - Automatic Batch Control 56**
 - Setup with MeterView Pro 58**
 - Operate with MeterView Pro 58**
- Advanced Setup & Programming..... 59**
 - Advanced Features Menu..... 59**
 - Advanced Features Menu & Display Messages..... 59
 - Function Keys Operation 60
 - Digital Inputs Operation 60
 - Advanced Setup and Calibration..... 61
 - Maximum/Minimum Readings..... 61
 - Rounding Feature (round)..... 61
 - Modbus RTU Serial Communications (SEr iRL)..... 61
 - Select Menu (SELEct)..... 62
 - Programmable Function Keys User Menu (uSEr)..... 64
- Troubleshooting 65**
 - Diagnostics Menu (d iRL) 65
 - Testing the Display LEDs..... 65
 - Determining Software Version 65
- Reset Controller to Factory Defaults..... 65**
 - Factory Defaults & User Settings..... 66
- Troubleshooting Tips..... 67**

Table of Figures

Figure 1. Enclosure Dimensions – Front View	20
Figure 2. Enclosure Dimensions – Side Cross Section View	20
Figure 3. Flowmeter Supply Voltage Selection	23
Figure 4. Programming Lockout Jumper Selection.....	23
Figure 5. Wire Security Seal and Bracket.....	24
Figure 6. Wire Loop through Rear Case Pass-Through	24
Figure 7. Wire Loop through Security Bracket Pass-Through	24
Figure 8. Close and Crimp Seal Wire Security Loop	24
Figure 9. Integrated PROVu Required Connections	25
Figure 10. PROVu Electronics Module Layout	26
Figure 11. USB Connection	26
Figure 12. Power Connections	27
Figure 13. Flowmeter Powered by Internal Power Supply	28
Figure 14. Flowmeter Powered by External Supply.....	28
Figure 15. Self-Powered Magnetic Pickup Coil Flowmeter	28
Figure 16. NPN open Collector Input	28
Figure 17. PNP Sensor Powered by Internal Supply	28
Figure 18. Switch Input Connections.....	28
Figure 19. Relay Connections	29
Figure 20. Interlock Connection	29
Figure 21. AC and DC Loads Protection.....	29
Figure 22. Low Voltage DC Loads Protection	29
Figure 23. RS-485 Diagnostic LEDs	30
Figure 24. Three-Wire RS-485 Connection	30
Figure 25. Digital Input and Output Connections	30
Figure 26. F4 Digital Input Connections	30
Figure 27. 4-20 mA Output Connections	31
Figure 28. Analog Output Supply Powering Other Devices.....	31

Introduction

The PD8-6310-WM ProtEX-MAX is an explosion-proof, NTEP® Certified pulse input batch controller certified as a weighing and measuring device that provides simple independent batch control operations where local control is preferred to expensive plant operation systems. The controller features a dual-line display, with a main display 0.60" (15 mm) high, and a second display of 0.46" (12 mm) high superluminous LED digits, which can be read in any lighting condition, including direct sunlight. The controller is housed in a die-cast aluminum, field-mountable, NEMA 4X/IP68 rated enclosure for convenient indoor and outdoor installation.

The controller has a mechanically secured programming lockout feature. A cable with compression seal may be secured to prevent the removal of the rear case, preventing access to the programming lockout jumper.

The controller comes programmed for easy start, pause, stop, and batch size (preset) changes. The second display can be programmed to display rate, grand total, batch count, or preset by cycling the Stop (F3) button. Digital inputs come standard.

Single and multi-stage batching is possible with up to four on-board relays. Each batch control relay may have a unique preclose amount when used for multi-stage batching. Manual start batching is default, but automatic batching with a restart after a programmed time delay from the completion of the last batch is also possible.

Overrun correction adjusts the closing of the batch control relays to adjust for inaccuracies from batch to batch. This increases accuracy over time as systems wear out. The overrun correction feature is capable of compensating for inaccuracies of up to 1% of the programmed preset value.

The controller accepts pulse (e.g. ±40 mV to ±8 V), square wave (0-5 V, 0-12 V, or 0-24 V), open collector, NPN, PNP, TTL or switch contact signals.

The PD8-6310-WM batch controller comes with four SPDT relays, a 4-20 mA output, two 24 VDC power supplies, five digital inputs and four digital outputs, and RS-485 serial communications, making it an excellent addition to any system.

Ordering Information

85-265 VAC Models

Model	Standard Features
PD8-6310-6H7-WM	4 relays, 4-20 mA output, 5 Digital Inputs, 4 Digital Outputs, RS-485 Communications

12-24 VDC Models

Model	Standard Features
PD8-6310-7H7-WM	4 relays, 4-20 mA output, 5 Digital Inputs, 4 Digital Outputs, RS-485 Communications

Note: 24 V flowmeter power supply standard on all models.

Accessories

Model	Description
PDA0001	3/4" M-NPT to F-M20 Reducer
PDA0002	3/4" M-NPT to 1/2" F-NPT Reducer
PDAPLUG75	3/4" Metal Conduit/Stopping Plug
PDA-SSTAG	Custom Stainless Steel Tag (see website for convenient ordering form)
PDA6848	2" U-Bolt Kit Zinc Plated Steel
PDA6848-SS	2" U-Bolt Kit Stainless Steel
PDA7485-I	RS-232 to RS-485 isolated converter
PDA8485-I	USB to RS-485 isolated converter

SafeTouch Buttons

To make it possible to program and operate the ProtEX-MAX in a hazardous area, the programming buttons that are located behind the glass window can be operated without removing the cover by using the SafeTouch through-glass buttons. The operator puts their finger on the glass over the button and the button is actuated.



To learn more about SafeTouch buttons, see this video:

predig.com/videos/Safetouch_Buttons

Helpful Videos

There are several videos that will help you get a better understanding of the features and functionality of the ProtEX-MAX products. Since the ProtEX-MAX meters have the same general features and functionality of the ProVu meters, appropriate videos for the ProVu controller are also included.

PROVu Batch Controllers

These provide simple batch control with features like preclose relays and automatic overrun correction.

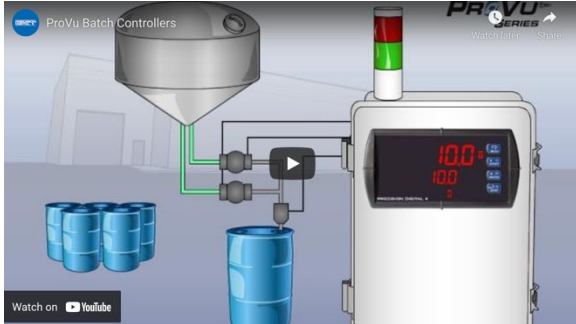

<https://www.predig.com/videos/KN6Y6R0I10E>

PROVu Function Keys Tutorial

Learn how the PROVu's function keys increase the utility of the PROVu.



<https://www.predig.com/videos/WMBYKlavW-Q>

Connect a PROVu to a PC Using MeterView Pro

Learn how easy it is to use MeterView Pro software.



https://www.predig.com/videos/PC_Connect

MeterView Pro USB Programming Software

Learn how easy it is to program a ProVu PD6000 process meter.

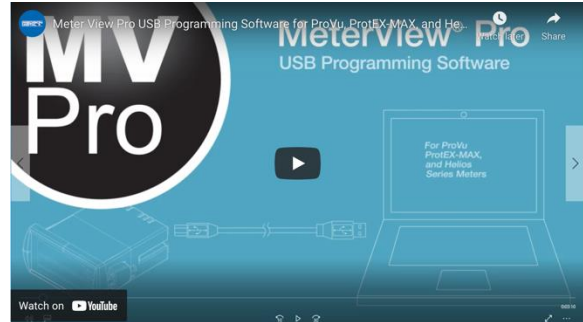

https://www.predig.com/videos/MVPro_SW

ProtEX-MAX Explosion-Proof Family

The ProtEX-MAX Series has been designed to offer the functions and features of any ProVu in a great looking explosion-proof housing.



https://www.predig.com/videos/ProtEXMAX_Overview

Key Features

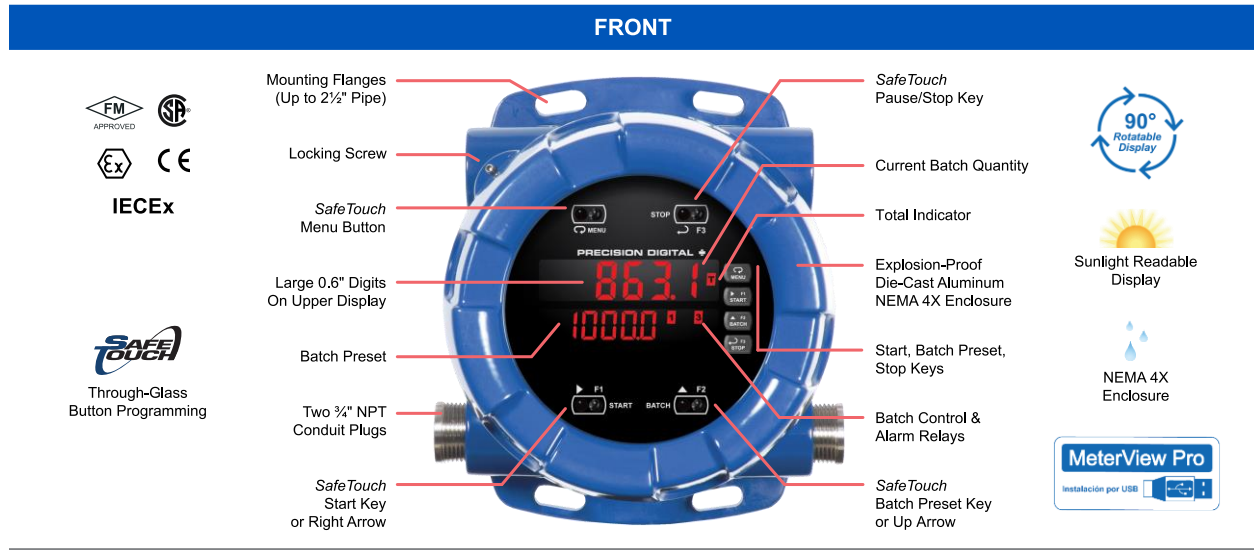

CONNECTIONS

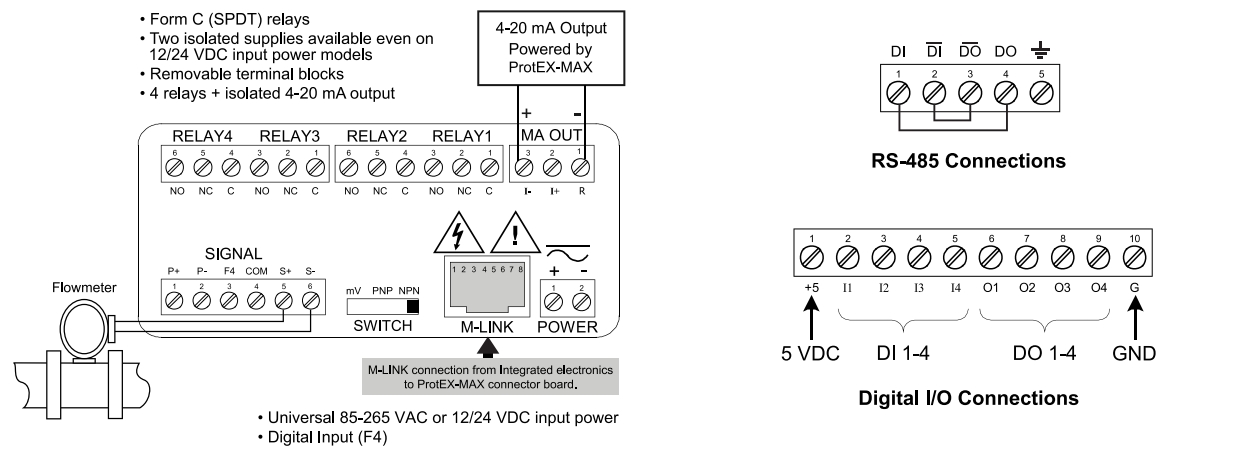

Connections for PD8-6310-6H7-WM & PD8-6310-7H7-WM

The Only Explosion-Proof Batch Controller You Will Ever Need

The ProtEX-MAX PD8-6310-WM is an explosion-proof batch controller with four internal relays that can be used for single or multi-stage batch control.

The first thing you notice about the PD8-6310-WM is its modern looking, rugged, die-cast aluminum housing with convenient mounting flanges. Housed inside this enclosure is a dual-line, 6-digit display that is usually setup to show the current batch quantity and the batch preset on the two lines. START, BATCH, and STOP buttons (which can be operated remotely or without removing the cover) come setup by default for batch control operation. The START button starts the batch. The BATCH button shows the preset value. The STOP button pauses or stops the batch.

The controller has a mechanically secured programming lockout feature. A cable with compression seal may be secured to prevent the removal of the rear case, preventing access to the programming lockout jumper.

The PD8-6310-WM is approved as a complete product by FM and CSA and also carries ATEX and IECEx certification. One of the more convenient features of the PD8-6310-WM is its through-glass SafeTouch buttons which allow the controller to be operated without removing its cover. Just put your finger on the glass over the button to actuate it. The PD8-6310-WM can also provide 5, 10, or 24 VDC to power the flowmeter.

A ProtEX-MAX batch controller can be programmed for a wide variety of applications. Setup is easy for single or multi-stage batching. Automatic overrun correction keeps the batch size accurate, even over time. The PD8-6310-WM can display the number of batches that have been run and the total amount of product that has been batched. These features and capabilities can easily be programmed without removing the cover using SafeTouch buttons in a hazardous area or with free MeterView Pro PC-based software in a safe area.

Easy Programming Methods

The ProtEX-MAX can be programmed in a hazardous area with the through-glass SafeTouch buttons without removing the cover, in a safe area with the front panel push buttons with the cover removed, or in a safe area with free, PC-based MeterView Pro software. MeterView Pro is resident on the ProtEX-MAX and is accessed by a provided USB cable, so it is by far the easiest way to program the ProtEX-MAX.

The controller comes from the factory pre-calibrated for all pulse inputs, so the user need only set the mV / PNP / NPN switch in the appropriate position based on the input and also set the desired excitation voltage level. Once programming is completed, the controller can be locked with a password.

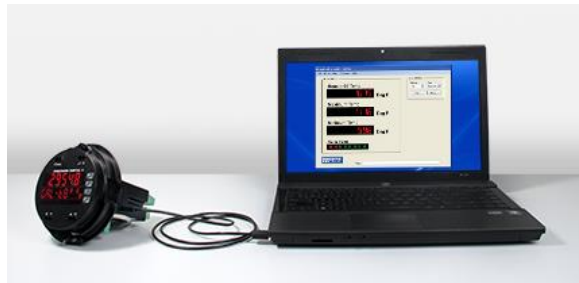

The ProtEX-MAX comes preloaded with free MeterView Pro programming software that connects and installs directly to your PC with a standard USB cable, also provided free with each instrument. This eliminates the need to insert CDs, install drivers, or download software from the internet. When you connect your ProtEX-MAX to your PC, MeterView Pro is downloaded to your PC, the software automatically selects the model you are programming, and you're ready to start programming immediately. Further simplifying the programming process, the ProtEX-MAX can be powered from the USB port, so no need to apply external power while programming your controller. In addition to programming, the software will also allow you to monitor, and datalog a ProtEX-MAX using your PC. You can also generate and save programming files for later use.

Advanced Display Features

Display What You Want

The most common setup for these batch controllers is to display the batch total on the main display and batch preset on the second display. This allows the user to monitor the batch as it progresses and compare it to the total batch size. Other possible setups include displaying the batch total and flow rate, batch total and batch count, and batch total and grand total.

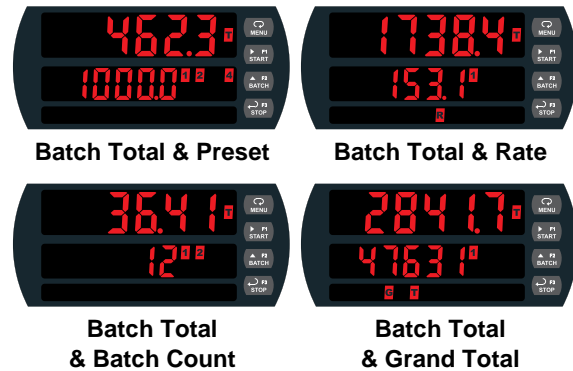

Easy to Program

The controller may be calibrated using the K-Factor function. Most flowmeter manufacturers provide this information with the device. Enter the K-Factor (Factor) menu and select the decimal point with highest resolution possible and program the k-factor value (i.e. pulses/gal). The controller will automatically calculate the flow rate using the k-factor and the time base selected.

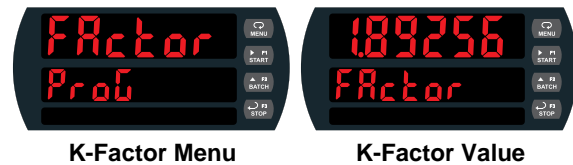

Super-Bright Display

The ProtEX-MAX comes standard with a super-bright display, with LEDs that are visible even in direct sunlight. The display also has up to eight levels of adjustable intensity for optimum visibility in any lighting condition.

Rounding for Even Steadier Display

The rounding feature is used to give the user a steadier display with fluctuating signals. It causes the display to round to the nearest value according to the rounding value selected (1, 2, 5, 10, 20, 50, or 100). For example, with a rounding value of 10, and an input of 12346, the display would indicate 12350.

Batch Controller Capabilities

A ProtEX-MAX batch controller can be programmed for a wide variety of single or multi-stage batching applications and set up to run in either manual or automatic operation. Batch size can be displayed on the controller and is easily programmed and changed if needed. The controller can even display the number of batches that have been run. Automatic overrun correction keeps the batch size accurate, even over time and with system wear. The controller can display the rate with a time base of seconds, minutes, hours or days. The user can program a conversion factor, configure a non-resettable grand total, and configure password protection.

Manual or Automatic Batch Control

Batches may be started manually with the START front panel button, or with a remote digital input trigger. Batches may also be programmed to start automatically after a 0 to 999.9 second delay after the end of the last completed batch. A manually stopped batch will only restart after the START button is pressed or digital input triggered.

Automatic Overrun Correction

The ProtEX-MAX batch controller will correct for batch overrun or shortages automatically. By tracking the amount the batch was off by, the controller will automatically adjust the batch by modifying the batch relay deactivation time.

Single and Multi-Stage Batching

The ProtEX-MAX can be used as a single or multi-stage batch controller. Relays assigned to the total act as batch control relays, with additional relays beyond the first including a preclose value. The preclose deactivates the relay before the batch is finished, to allow slower fill rates and a more accurate batch finish. Each additional stage batching relay has an individually programmable preclose amount.

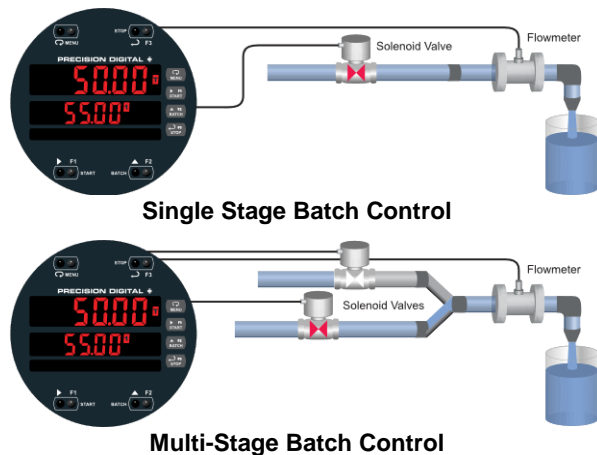

Quick Preset Changes

The front panel BATCH key is configured by default to access the preset menu. The preset may be changed quickly and easily between batches without the need to enter setup menus.

Non-Resettable Grand Total

The user can set up the grand total to be non-resettable by entering a specific password. Once this is done, the grand total can never be reset.

Total Conversion Factor

The user can enter a conversion factor that allows the controller to display total in different units than the rate. For instance, an operator could measure flow rate in gallons per minute and grand total in millions of gallons.

Grand Total & Rate Alarms

The ProtEX-MAX's four internal relays can be set up to alarm when the grand total reaches a user-defined set point or when the rate is above or below a certain value. Rate alarms are only activated when the batching process is running. A variety of reset modes are available and the user can also program time delays and fail-safe operation.

F4 Digital Input

The digital input can be used for a variety of functions such as starting or stopping a batch, resetting the total, or resetting an alarm relay. This is ideal for installations where the controller is inaccessible behind a cover, or where an additional function key is needed for customized operation.

Remote Operation of Controller

There are four digital inputs that can be programmed to mimic the MENU, START, BATCH, and STOP buttons that could be controlled by a control station* suitable for location in a hazardous area.

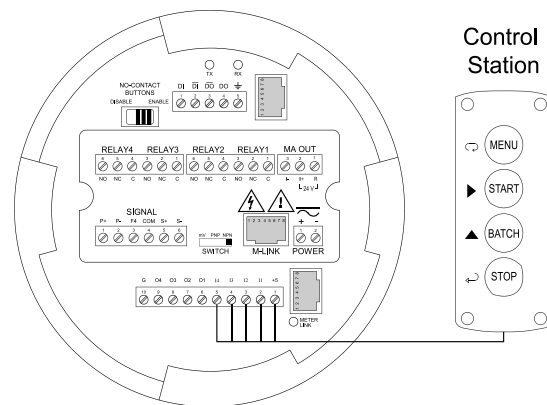

* Control station must be approved for hazardous locations

Physical Features

The ProtEX-MAX is designed for ease-of-use in safe and hazardous applications. The ProtEX-MAX is housed in a rugged NEMA 4X explosion-proof enclosure, can operate over a wide temperature range, includes removable screw terminal connectors, has worldwide approvals for use in hazardous areas, and features through-glass buttons for easy controller operation without the need to remove the cover. All of these features are backed by a 3-year warranty.

Super-Bright LED Display

The ProtEX-MAX features a dual-line 6-digit display with super-bright LEDs, our brightest ever. These allow the display to be read in any lighting condition, even in direct sunlight.



SafeTouch Through-Glass Buttons

The ProtEX-MAX is equipped with four sensors that operate as through-glass buttons so that it can be programmed and operated without removing the cover (and exposing the electronics) in a hazardous area. These buttons can be disabled for security by selecting the DISABLE setting on the NO-CONTACT BUTTONS switch located on the back of the electronics module, inside the enclosure.

Rugged, Heavy-Duty Enclosure

The ProtEX-MAX is housed in a rugged NEMA 4X, 7, & 9, IP68 die-cast aluminum enclosure, designed to withstand harsh environments in safe and hazardous areas over a wide temperature range.



Wide Viewing Angle

Customers can't always look at the display from straight on, so the window and display module have been optimized to provide a wide viewing angle of approximately $\pm 40^\circ$; nearly twice that of the competition.



Built-In Mounting Flanges

The ProtEX-MAX is equipped with four slotted flanges for wall mounting or NPS 1½" to 2½" or DN 40 to 65 mm pipe mounting.



Flexible Mounting & Wiring

The ProtEX-MAX features four ¾" NPT threaded conduit openings so that wiring can be routed to the most convenient conduit connection(s). Two ¾" NPT metal conduit plugs with 12 mm hex key fitting come installed.



Rotatable Display

The ProtEX-MAX rotatable display, along with four available conduit connections, provide for numerous installation options. The display can be rotated in 90° increments. Rotate it 90° for horizontal mounting.



Vertical Mounting

Horizontal Mounting

Perfect & Secure Fit Every Time

The internal cast rails ensure the ProtEX-MAX assembles together perfectly, quickly and securely; and everything lines up for optimal viewing every time. There are no standoffs to worry about breaking or getting out of alignment. Two spring-loaded, self-retaining, thumbscrews make the assembly a snap, while pressing the display as close to the glass as possible to improve wide angle viewing.

Stainless Steel Tags

PDA-SSTAG is a laser etched stainless steel tag accessory for any of your Precision Digital meters. The tag features custom text for equipment identification, instruction, or whatever else is needed in your facility. Each tag comes with a stainless steel wire and lead seal for easy mounting wherever you need it.



Removable Screw Terminals

Industrial applications require screw terminal connections for easy field wiring, and the ProtEX-MAX goes one step further in convenience by also making them removable.



Note: The above photograph is representative of the back of the PD8-6310-WM in every regard except for the signal input connector. See *Figure 10. ProVu Electronics Module Layout* on page 26 for actual input signal connections.

USB Port MeterView Pro

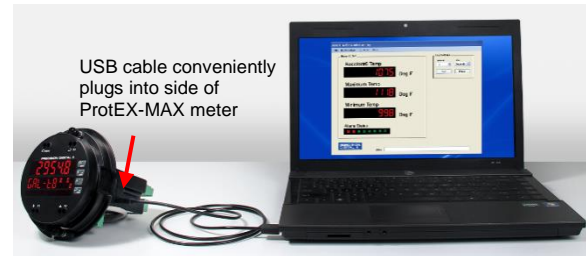

Hazardous Area Approvals

The ProtEX-MAX's approvals allow it to be used in hazardous areas around the world. These include: FM Approved as Explosion-Proof / Dust-Ignition-Proof / Flame-Proof, CSA Certified as Explosion-Proof / Dust-Ignition-Proof, and ATEX and IECEx Certified as Flame-Proof.

Wide Operating Temperature Range

The ProtEX-MAX can operate from -40 to 60°C (-40 to 140°F) meaning it can be installed in a wide variety of indoor and outdoor industrial applications. And over this range, the ProtEX-MAX will drift no more than 0.005% of calibrated span/°C max from 0 to 65°C ambient and 0.01% of calibrated span/°C max from -40 to 0°C ambient.

Specifications

Except where noted all specifications apply to operation at +25°C.

General

Display	Display Line 1: 0.60" (15 mm) high, red LEDs Display Line 2: 0.46" (12 mm) high, red LEDs 6 digits per line (-99999 to 999999), with lead zero blanking
Display Intensity	Eight user selectable intensity levels. Default intensity is six.
Display Update Rate	5/second (200 ms)
LED Status Indicators	See <i>LED Status Indicators</i> on page 32 for details.
Overrange	Display flashes 999999
Underrange	Display flashes -99999
Default Display Assignment	Line 1 displays batch total. Line 2 displays batch preset, and can be switched to show grand total, or batch count with the STOP key.
Custom Display Assignment	Display lines 1 and 2 may be assigned to rate, total, grand total, batch count, preset, set points, units (second display only), alternating R & T, R & GT, preset & rate, max & min, or a Modbus display register. Any rate/total/grand total display may be programmed to alternate with a custom unit or tag.
Alternating Display	Displays alternate every 10 seconds when display is selected, or the batch is paused.
Programming Methods	Four SafeTouch through-glass buttons when cover is installed. Mechanical buttons can be used with the cover removed. Free PC-based USB MeterView Pro programming software.
Recalibration	All ranges are calibrated at the factory. Recalibration is recommended at least every 12 months.
Max/Min Display	Max/min readings reached by the process are stored until reset by the user or until power to the controller is cycled.
Rounding	Select 1, 2, 5, 10, 20, 50, or 100 (e.g. rounding = 10, value = 123.45, display = 123.50).
Password	Three programmable passwords restrict modification of programmed settings and two prevent resetting the totals. Pass 1: Allows use of function keys and digital inputs Pass 2: Allows use of function keys, digital inputs and editing set/reset points Pass 3: Restricts all programming, function keys, and digital inputs. Total Password: Prevents resetting the total manually Gtotal Password: Prevents resetting the grand total manually
Non-Volatile Memory	Total and Grand Total values, and all programmed settings are stored in non-volatile memory for a minimum of ten years if power is lost.

Power Options	85-265 VAC 50/60 Hz; 90-265 VDC, 20 W max; 12-24 VDC, 12-24 VAC, 15 W max. Powered over USB for configuration only.
Fuse	Required external fuse: UL Recognized, 5 A max, slow blow; up to 6 controllers may share one 5 A fuse
Normal Mode Rejection	Greater than 60 dB at 50/60 Hz
Isolation	4 kV input/output-to-power line 500 V input-to-output or output-to-P+ supply
Overvoltage Category	Installation Overvoltage Category II: Local level with smaller transient overvoltages than Installation Overvoltage Category III.
Environmental	T6 Class operating temperature range Ta = -40 to 60°C T5 Class operating temperature range Ta = -40 to 65°C Storage temperature range: -40 to 85°C (-40 to 185°F) Relative humidity: 0 to 90% non-condensing
Max Power Dissipation	Maximum power dissipation limited to 15.1 W
Connections	Power, signal, relays, mA out: Removable screw terminal blocks accept 12 to 22 AWG wire. RS-485: Removable screw terminal block accepts 16 to 30 AWG wire. Digital I/O: Removable screw terminal blocks accept 16 to 30 AWG wire.
Enclosure	Explosion-proof die-cast aluminum with glass window, corrosion resistant epoxy coating, color: blue NEMA 4X, 7, & 9, IP68 Default conduit connections: Four ¾" NPT threaded conduit openings and two ¾" NPT metal conduit plugs with 12 mm hex key fitting installed. Additional conduit opening configurations may be available; verify quantity and sizes on specific device labeling during installation.
Mounting	Wall Mounting: Four (4) mounting holes provided for mounting controller to wall. See <i>Wall Mounting Instructions</i> on page 20 for additional details. Pipe Mounting: Optional pipe mounting kit (PDA6848) allows for pipe mounting. Sold separately. See <i>Pipe Mounting Instructions</i> on page 21 for additional details.
Tightening Torque	Power, signal, relays, mA out terminals: 5 lb-in (0.56 Nm) Digital I/O and RS-485: 2.2 lb-in (0.25 Nm)
Overall Dimensions	6.42" x 7.97" x 8.47" (W x H x D) (163 mm x 202 mm x 215 mm)
Weight	16.0 lbs (7.26 kg)
Warranty	3 years parts & labor. See Warranty Information and Terms & Conditions on www.predig.com for complete details.

Batch Controller Rate/Totalizer Display

Rate Display Indication	-99999 to 999999, lead zero blanking. "R" LED illuminates while displaying rate.
Batch Total & Grand Total Display	0 to 999,999; automatic lead zero blanking. "T" LED is illuminated while displaying batch total. "GT" LEDs are illuminated while displaying grand total. Up to 999,999 for batch total/preset. Up to 999,999,999 with grand total-overflow feature. "oF" is displayed to the left of grand total overflow and ▲ LED is illuminated.
Batch Total Decimal Point	Up to five decimal places or none: dddddd, dddddd, dddd, ddd, dd, or dddddd. Total decimal point is independent of rate decimal point.
Totalizer	Calculates total based on rate and field programmable multiplier to display total in engineering units. Time base must be selected according to the time units in which the rate is displayed.
Time Base	Second, minute, hour, or day
Batch Control Mode	Automatic or manual batch control
Manual Batch	The operator must press the START button every time a new batch is started. Press STOP to pause the batch and either press START to resume or STOP to stop the incomplete batch.
Automatic Batch	Once the START button is pressed, the batches will run automatically until the STOP button is pressed twice. The time delay between batches is entered during the setup.
Batch Time Delay	Programmable up to 999.9 seconds. This is the time delay between batches for automatic batch control. Allow sufficient time to put in place an empty container.
Batch Preset	The F2 key is assigned to the preset. The preset value is the total volume to be batched in each cycle.
Batch Pre-Close	The pre-close value is equal to the volume amount before reaching the preset value (batch size).
Single or Multi-Stage	Single Stage: Only relay 1 is used. Multi-Stage: Two or more relays are used to control the batch with more precision; this is done using multiple presets or using the pre-close feature.
Multiple Presets	Each relay de-energizes at its own preset value.
Remote Operation	Start / Stop / Batch Size buttons may be operated remotely by connecting a hazardous-area approved control station to the digital inputs.
Start	The F1 key is assigned to START batch. Press START to start a new batch in manual mode or a set of batches in automatic mode.
Pause / Stop	The F3 key is assigned to PAUSE / STOP. Press F3 once to pause and press it again to stop the batch process.

Automatic Overrun Correction	Adjusts the closing of the batch control relays to compensate for inaccuracies from batch to batch. The overrun correction feature is capable of compensating for inaccuracies of up to 1% of the programmed preset value. To achieve an accurate batch, the flow rate must be slowed down, such that the total most-right digit increments at a rate of less than 10 counts/second. The use of a dual-stage batch control is recommended.
Count Up or Count Down	Batch total and grand total can set to count up or count down, independently.
Start / Stop Batch	The F4 digital input is assigned to start & stop the batch, it is located on the input signal connector. A hazardous-area approved external push-button can be connected between terminal F4 and COM. Press the button once to start the batch and press it again to stop the batch.
High or Low Flow Alarm	The user may program any alarm for high or low trip point. The alarm detection is active only while the batch is running. Unused alarm LEDs and relays may be disabled (turned off).
Grand Totalizer Rollover	Grand totalizer rolls over when display exceeds 999,999,999. Relay status reflects display.
Grand Total Overflow	The grand total can display up to 999,999,999 using the overflow feature. After the value exceeds 999,999 a 3-digit value with the prefix "oF" toggles every 10 seconds. The overflow feature can be disabled by setting a grand total alarm that automatically resets the grand total when 999,999 is reached.
Grand Total Alarms	Up to three, user selectable under setup menu. Any set point can be assigned to grand total and may be programmed anywhere in the range of the controller for grand total alarm indication. Relay 1 should always be assigned to batch.
Programmable Delay on Release	0.1 and 999.9 seconds; applied to the first relay assigned to total or grand total. If the controller is programmed to reset total to zero automatically when the preset is reached, then a delay will occur before the total is reset.
Grand Total Reset	Via front panel button, external contact closure on digital inputs, automatically via user selectable preset value and time delay, or through serial communications.
Grand Total Reset Password	Grand total passwords may be entered to prevent resetting the grand total from the front panel.
Non-Resetable Grand Total	The grand total can be programmed as a non-resetable total by entering the password "050873".
Non-Volatile Memory	Total and Grand Total values, and all programmed settings are stored in non-volatile memory for a minimum of ten years if power is lost.

CAUTION

- Once the Grand Total has been programmed as "non-resetable" the feature **CANNOT** be disabled.

Pulse Inputs

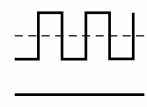
Inputs	Field selectable: Pulse or square wave 0-5 V, 0-12 V, or 0-24 V @ 30 kHz; TTL; open collector 4.7 kΩ pull-up to 5 V @ 30 kHz; NPN or PNP transistor, switch contact 4.7 kΩ pull-up to 5 V @ 40 Hz; Modbus PV (Slave)		
Isolated Flowmeter Power Supply	Terminals P+ & P-: 24 VDC ±10% All models selectable for 24, 10, or 5 VDC supply (internal jumper J4) All models rated @ 25 mA max		
Low Voltage Mag Pickup (Isolated)	Sensitivity: 40 mVp-p to 8 Vp-p		
Minimum Input Frequency	0.001 Hz Minimum frequency is dependent on high gate setting.		
Maximum Input Frequency	30,000 Hz (10,000 for low voltage mag pickup)		
Input Impedance	Pulse input: Greater than 300 kΩ @ 1 kHz. Open collector/switch input: 4.7 kΩ pull-up to 5 V.		
Input Threshold	Low	High	
Accuracy	±0.03% of calibrated span ±1 count		
Temperature Drift	Rate display is not affected by changes in temperature.		
Multi-Point Linearization	2 to 32 points		
Low-Flow Cutoff	0.1 to 999,999 (0 disables cutoff function). Point below at which display always shows zero.		
Decimal Point	Up to five decimal places or none: dddddd, dddddd, dddd, ddd, dd, or dddddd		
Calibration	May be calibrated using K-factor, internal calibration, or by applying an external calibration signal.		
K-Factor	Field programmable K-factor converts input pulses to rate in engineering units. May be programmed from 0.00001 to 999,999 pulses/unit.		
Calibration Range	Input 1 signal may be set anywhere in the range of the controller; input 2 signal may be set anywhere above or below input 1 setting. Minimum input span between any two inputs is 10 Hz. An error message will appear if the input 1 and input 2 signals are too close together.		
Filter	Programmable contact de-bounce filter: 40 to 999 Hz maximum input frequency allowed with low speed filter.		
Gate	Low gate: 0.1-99.9 seconds High gate: 2.0-999.9 seconds		

Relays

Rating	4 SPDT (Form C) internal rated 3 A @ 30 VDC and 125/250 VAC resistive load; 1/14 HP (≈ 50 W) @ 125/250 VAC for inductive loads
Noise Suppression	Noise suppression is recommended for each relay contact switching inductive loads; see <i>Switching Inductive Loads</i> on page 29 for details.
Relay Assignment	Relays may be assigned to batch control total, sampling, rate, or grand total alarms.
Pre-Close	0-100% of batch size, individually user programmable for each additional batch control relay beyond the first.
Alarm Deadband	0-100% of span, user programmable
High or Low Flow Alarm	User may program any alarm for high or low trip point. The alarm detection is active only while the batch is running. Unused alarm LEDs and relays may be disabled (turn off).
Relay Operation	<ul style="list-style-type: none"> • Manual or automatic batch control • Automatic (non-latching)¹ and/or manual alarm reset (acknowledge) • Latching (requires manual acknowledge) with or without clear • Pump alternation control (N/A to batch) • Sampling (based on set point and time) • Off (disable unused relays and enable Interlock feature) • Manual on/off control mode
Relay Reset (Acknowledge)	User selectable via programming buttons, F4 digital input, external contact closure on digital inputs, automatically via user selectable preset value and time delay, or through serial communications.
Alarm Time Delay	0 to 999.9 seconds, on & off relay time delays. Programmable and independent for each relay.
Fail-Safe Operation	Programmable and independent for each relay. Note: Relay coil is energized in non-alarm condition. In case of power failure, relay will go to alarm state.
Alarm Auto Initialization	When power is applied to the controller, relays will reflect the state of the input to the controller. ¹

1. Alarms are active only when the batch is running.

USB Connection

Function	Programming only
Compatibility	USB 2.0 Standard, Compliant
Connector Type	Micro-B receptacle
Cable	USB A Male to Micro-B Cable
Driver	Microsoft® Windows® XP/Vista/7/8/10
Power	USB port provides power to the controller for configuration only. DO NOT apply AC or DC power to the controller while the USB port is in use.

Isolated 4-20 mA Transmitter Output

Output Source	Rate/process, total, grand total, min, set points 1-4, Modbus register, or manual control mode		
Scaling Range	1.000 to 23.000 mA for any display range		
Calibration	Factory calibrated: 4.000 to 20.000 = 4-20 mA output		
Analog Out Programming	23.000 mA maximum for all parameters: Overrange, underrange, max, min, and break		
Accuracy	± 0.1% FS ± 0.004 mA		
Temperature Drift	0.4 µA/°C max from 0 to 65°C ambient, 0.8 µA/°C max from -40 to 0°C ambient Note: Analog output drift is separate from input drift.		
Isolated Transmitter Power Supply	Terminals I+ & R: 24 VDC ± 10%. Used to power the 4-20 mA output. All models rated @ 25 mA max.		
External Loop Power Supply	35 VDC maximum		
Output Loop Resistance	Power supply	Minimum	Maximum
	24 VDC	10 Ω	700 Ω
	35 VDC (external)	100 Ω	1200 Ω

RS-485 Serial Communications

Compatibility	EIA-485
Connectors	Removable screw terminal connector
Max Distance	3,937' (1,200 m) max
Status Indication	Separate LEDs for Power (METER LINK), Transmit (TX), and Receive (RX)

Modbus® RTU Serial Communications

Slave Id	1 – 247 (Controller address)
Baud Rate	300 – 19,200 bps
Transmit Time Delay	Programmable between 0 and 199 ms
Data	8 bit (1 start bit, 1 or 2 stop bits)
Parity	Even, Odd, or None with 1 or 2 stop bits
Byte-To-Byte Timeout	0.01 – 2.54 second
Turn Around Delay	Less than 2 ms (fixed)
Note:	Refer to the ProtEX-MAX Modbus Register Tables located at www.prediq.com for details.

Digital Input (F4)

Function	Start/Stop batch, remote operation of front-panel buttons, acknowledge/reset relays, reset max/min values. See <i>Function Keys & Digital I/O Available Settings</i> on page 64 for a complete list of capabilities.
Contacts	3.3 VDC on contact. Connect normally open contacts across F4 to COM
Logic Levels	Logic High: 3 to 5 VDC Logic Low: 0 to 1.25 VDC

Digital Inputs & Outputs

Function	Terminals provided for remote operation of all four programming / operation buttons. Other uses include acknowledge/reset relays and reset max/min values. See <i>Function Keys & Digital I/O Available Settings</i> on page 64 for a complete list of capabilities.
Channels	4 digital inputs & 4 digital outputs
Digital Input Logic High	3 to 5 VDC
Digital Input Logic Low	0 to 1.25 VDC
Digital Output Logic High	3.1 to 3.3 VDC
Digital Output Logic Low	0 to 0.4 VDC
Source Current	10 mA maximum output current
Sink Current	1.5 mA minimum input current
+5 V Terminal	To be used as pull-up for digital inputs only. Connect normally open push buttons across +5 V & DI 1-4.

WARNING

- **DO NOT** use +5 V terminal to power external devices.

MeterView Pro Software

Availability	Download directly from controller or from www.prediq.com/download_software
System Requirements	Microsoft® Windows® XP/Vista/7/8/10
Communications	USB 2.0 (for programming only) (USB A Male to Micro-B Cable) RS-485 to USB converter (programming, monitoring, and data logging)
Configuration	Configure controllers one at a time
Power	USB port provides power to the controller for configuration only. DO NOT apply AC or DC power to the controller while the USB port is in use.
Batch Control	Use MeterView Pro to control the batch, change the preset, reset totals, and test the relays.
Data Logging	Use MeterView Pro for data logging of the batch process.

Compliance Information

NTEP Certification

Certificate No.	14-061
Definition	Register for Meter. Stationary Wholesale Liquid Register/Controller. Digital Electronic Model: PD63XX Series, PD8-63XX Series
Evaluation Criteria	NIST Handbook 44 Specifications, Tolerances, and Other Technical Requirements for Weighing and Measuring Devices, 2014 Edition. NCWM Publication 14 Measuring Devices, 2014 Edition.

National Conference on Weights and Measures (NCWM) National Type Evaluation Program (NTEP)

Electromagnetic Compatibility

Emissions	EN 55022 Class A ITE emissions requirements
Radiated Emissions	Class A
AC Mains Conducted Emissions	Class A
Immunity	EN 61326-1 Measurement, control, and laboratory equipment EN 61000-6-2 EMC heavy industrial generic immunity standard
RFI - Amplitude Modulated	80 -1000 MHz 10 V/m 80% AM (1 kHz) 1.4 - 2.0 GHz 3 V/m 80% AM (1 kHz) 2.0 - 2.7 GHz 1 V/m 80% AM (1 kHz)
Electrical Fast Transients	±2kV AC mains, ±1kV other
Electrostatic Discharge	±4kV contact, ±8kV air
RFI - Conducted	10V, 0.15-80 MHz, 1kHz 80% AM
AC Surge	±2kV Common, ±1kV Differential
Surge	1KV (CM)
Power-Frequency Magnetic Field	30 A/m 70%V for 0.5 period
Voltage Dips	40%V for 5 & 50 periods 70%V for 25 periods
Voltage Interruptions	<5%V for 250 periods

Note: Testing was conducted on meters with cable shields grounded at the point of entry representing installations designed to optimize EMC performance.

Product Ratings and Approvals

FM Enclosure: Type 4X; IP66
Class I, Division 1, Groups B, C, D
Class II, Division 1, Groups E, F, G
Class III, Division 1, T5/T6
Class I, Zone 1, AEx d, IIC Gb T5/T6
Zone 21, AEx tb IIIC T90°C; Ta = -40°C to +65°C
T6 Ta = -40°C to +60°C; T5 Ta = -40°C to +65°C
Certificate Number: 3047283

CSA Class I, Division 1, Groups B, C, D
Class II, Division 1, Groups E, F, G
Class III, Division 1
Class I Zone 1 Ex d IIC
Zone 21 Ex tb IIIC T90°C
-40°C < Tamb. < +60°C; Temperature Code T6
-40°C < Tamb. < +65°C; Temperature Code T5
Enclosure Type 4X & IP68
Certificate Number: 2531731

ATEX  II 2 G D
Ex d IIC T* Gb
Ex tb IIIC T90°C Db IP68
Ta = -40°C to +°C
*T6 = -40°C to +60°C
*T5 = -40°C to +65°C
Certificate number: Sira 12ATEX1182

IECEx Ex d IIC T* Gb
Ex tb IIIC T90°C Db IP68
Ta = -40°C to +°C
*T6 = -40°C to +60°C
*T5 = -40°C to +65°C
Certificate Number: IECEx SIR 12.0073

Special Conditions for Safe Use:

Use suitably certified and dimensioned cable entry device and/or plug. The equipment shall be installed such that the supply cable is protected from mechanical damage. The cable shall not be subjected to tension or torque. If the cable is to be terminated within an explosive atmosphere, then appropriate protection of the free end of the cable shall be provided. Cable must be suitable for 90°C.

Year of Construction

This information is contained within the serial number with the first four digits representing the year and month in the YYYYMM format.

For European Community: The ProtEX-MAX must be installed in accordance with the ATEX directive 94/9/EC, and the product certificate Sira 12ATEX1182.

EU Declaration of Conformity

EU Declaration of Conformity is available in the Documentation CD provided with the product under the **EU DoC** menu.

Safety Information

⚠ CAUTION

- Read complete instructions prior to installation and operation of the controller.

⚠ WARNINGS

- Risk of electric shock or personal injury.
- Hazardous voltages exist within enclosure. Installation and service should be performed only by trained service personnel.

Installation

Install in accordance with applicable local and national regulations (e.g. NEC).

For Installation in USA

The ProtEX-MAX must be installed in accordance with the National Electrical Code (NEC) NFPA 70.

For Installation in Canada

The ProtEX-MAX must be installed in accordance with the Canadian Electrical Code CSA 22.1. All power supplies below 36 V and input circuits must be derived from a CSA Approved Class 2 source.

For European Community

The ProtEX-MAX must be installed in accordance with the ATEX directive 94/9/EC and the product certificate Sira 12ATEX1182.

⚠ WARNINGS

- Disconnect from supply before opening enclosure.
- Keep cover tight while circuits are live.
- Conduit seals must be installed within 18" (450mm) of the enclosure or within 2" (50mm) for Zone installations.

Wiring connectors are accessed by opening the enclosure. To access electrical connectors, remove the 2 captive screws and then remove the electronics module. Connectors are on the rear of the electronics module.

Unpacking

Remove the controller from box. Inspect the packaging and contents for damage. Report damages, if any, to the carrier.

If any part is missing or the controller malfunctions, please contact your supplier or the factory for assistance.

Pre-Installed Conduit Plugs

The ProtEX-MAX is supplied with two pre-installed conduit plugs for installations that do not require the use of all four conduit entries. The conduit/stopping plugs include an internal hexagonal socket recess for removal. The conduit plugs and their factory installation are included in all hazardous area approvals of this product.

⚠ WARNING

- In hazardous areas, conduit and conduit/stopping plugs require the application of non-setting (solvent free) thread sealant. It is critical that all relevant hazardous area guidelines be followed for the installation or replacement of conduit or plugs.

Cover Jam Screw



The cover jam screw should be properly installed once the controller has been wired and tested in a safe environment. The cover jam screw is intended to prevent the removal of the controller cover in a hazardous environment without the use of tools. Using a M2 hex wrench, turn the screw clockwise until the screw contacts the controller. Turn the screw an additional 1/4 to 1/2 turn to secure the cover.

⚠ CAUTION

- Excess torque may damage the threads, screw head, and wrench.

Mounting

The ProtEX-MAX has four slotted mounting flanges that may be used for pipe mounting or wall mounting. Refer to *Figure 1* and *Figure 2* below.

WARNING

- Do not attempt to loosen or remove flange bolts while the meter is in service.

Mounting Dimensions

All units: inches (mm)

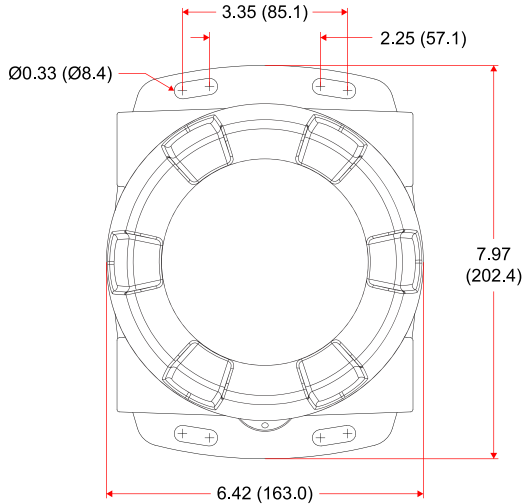

Figure 1. Enclosure Dimensions – Front View

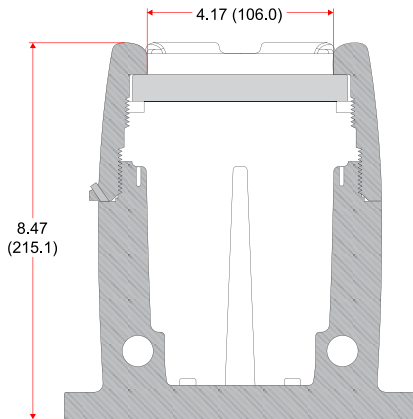

Figure 2. Enclosure Dimensions – Side Cross Section View

Wall Mounting Instructions

The controller can be mounted to any wall or flat surface using the four provided mounting holes located in the cast-in flanges. In addition, the internal electronic assembly can be rotated to allow the enclosure to be mounted in any position. To mount the controller to a wall, follow these instructions:

- Prepare a section of wall approximately 7" x 8.5" (178 mm x 216 mm) for controller mounting by marking with a pencil the mounting holes (shown in *Figure 1*) on the wall.
- Select the appropriate mounting screws for the mounting surface to be used. The mounting holes diameter is shown on *Figure 1*.
Note: Mounting screws are not included.
- Using a drill bit slightly smaller than the girth of the mounting screws, pre-drill holes at the mounting locations previously marked.
- Insert mounting screws into the four mounting holes and screw them into the pre-drilled holes.



Download free 3-D CAD files of these instruments to simplify your drawings!

predig.com/documentation-cad

Pipe Mounting Instructions



The controller can also be mounted to a pipe using an optional U-Bolt kit. This kit includes two U-bolts, the necessary hardware, and is available in zinc plated steel ([PDA6848](#)) and 316 stainless steel ([PDA6848-SS](#))



To mount the controller using a U-Bolt kit, follow these instructions:

- Orient the groove on the back of the instrument with the pipe and secure it to the pipe with the two U-bolts and hardware provided.



Vertical Pipe Mounting

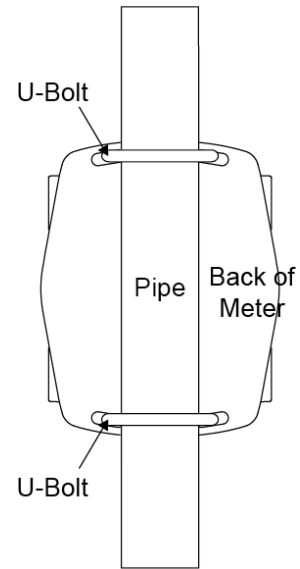

Horizontal Pipe Mounting

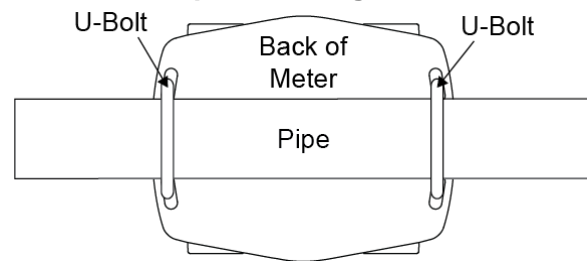

Installation Overview

We recommend the following sequence for getting the controller into service:

1. **DO NOT** apply AC or DC power to the controller.
2. Connect the controller to the PC with the USB cable provided. **DO NOT** use a different USB cable.
3. If MeterView Pro (MVPro) is already installed in your computer, then the program will launch automatically in most systems. If the program does not start automatically, double-click on the MVPro icon.
4. If MVPro is not installed, follow the instructions provided below.
5. Use MVPro to configure the controller for your application.
6. Disconnect the USB cable from the controller.
7. Apply power and signal and check operation of the controller.
8. Install the controller and put into service.
9. Make any programming adjustments using the programming buttons.

MeterView Pro Software

The easiest and quickest way to program your ProtEX-MAX controller is to use the FREE MeterView Pro programming software. This software is loaded into the controller and connects and installs directly to your PC with the USB cable provided. **DO NOT** use a different USB cable. We recommend that the first thing you do after taking the controller out of the box is connect the ProtEX-MAX to your PC with the provided USB cable. **DO NOT** apply AC or DC power to the controller while your PC is connected to the controller as it will disrupt the USB connection. It is not necessary to apply an input signal.

MeterView Pro programming software is intuitive, and most customers can get their controller programmed as they like without even looking in the manual.

Watch MeterView Pro Software Video at www.prediq.com/meterviewpro

MeterView Pro Installation

1. Connect one end of the provided USB cable to the controller and the other end to the computer. The computer will automatically install the driver software it needs to talk to the controller. Follow the on-screen instructions and allow sufficient time for the process to complete. This can take a few minutes. If the process is interrupted, then it could leave the system in an unstable condition.

⚠️ WARNINGS

- Only one controller may be connected at a time. Attaching multiple controllers will cause a conflict with the controller software.
- **DO NOT** apply AC or DC power to the controller when using the USB connection.
- When using the USB connection, the controller should only be connected to a computer when both devices are in a non-hazardous area.

2. Once the driver is installed, an AutoPlay dialog should appear for the drive "MAINSTAL." Click "Open folder to view files."

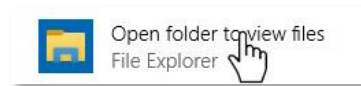

If the computer does not display an AutoPlay dialog for the drive "MAINSTAL," you should open My Computer and double-click on the drive labeled "MAINSTAL."

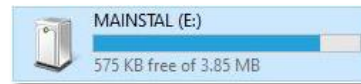

3. Double-click on the file named "MAStart." The program will open a few windows and install two programs on your computer. Simply follow the on-screen instructions until you see one of the dialogs below. If you receive a "User Account Control" warning, click "Yes."

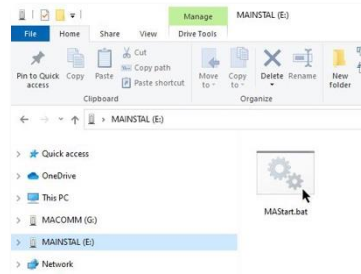

4. If there is an update available, click the "Update" button to install the new version. Otherwise, click "Configure" to begin programming your controller.

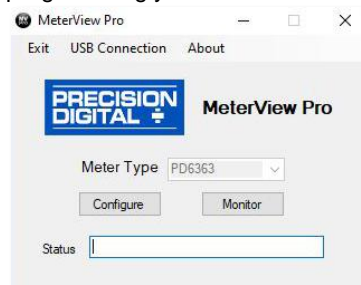

Note: If you decide to update your MeterView Pro software, once the installation has completed, you will be asked if you want to update the setup files located on the controller itself. This way, you will always have the most current version on the controller for future installs.

⚠️ WARNING

- **DO NOT** unplug the controller while the new installation files are being written to it. The controller will display a warning during the process and you will receive an on-screen notification once the process is complete.

Controller Supply Voltage Selection (P+, P-)

All controllers, including models equipped with the 12-24 VDC power option, are shipped from the factory configured to provide 24 VDC power for the flowmeter or sensor.

If the flowmeter requires 5 or 10 VDC excitation, the switch labeled P+/P- must be configured accordingly.

To access the voltage selection jumper:

1. Remove all the connectors.
2. Unscrew the back cover.
3. Slide the back cover about 1 inch.
4. Configure the J4 jumper, located behind the input signal connector, for the desired excitation voltage as shown.

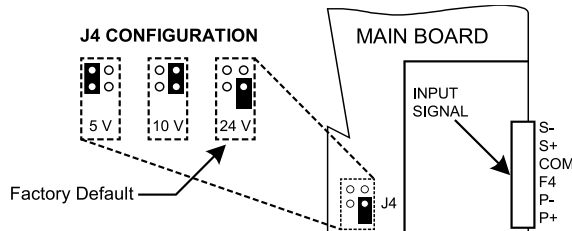

Figure 3. Flowmeter Supply Voltage Selection

Programming Lockout Jumper (NTEP Lockout)

All controllers include a programming lockout jumper. With this jumper installed, the controller will not allow access to the programming menus. If the Menu button is pressed, the controller will display Locked Seal (LCKD SEAL). The controller will still allow all batch controller operations to function, such as the START, BATCH, and STOP buttons.

CAUTION

- **Complete Setup Before Installing Lockout Jumper**
Set up the controller with all necessary settings prior to installing the lockout jumper. Installing the programming lockout jumper will prevent access to the programming menus.

The jumper may be removed to regain access to the programming menus.

Combined with sealing the rear case to restrict access to the programming lockout jumper, the controller meets the requirements for National Conference on Weights and Measures (NCWM) National Type Evaluation Program (NTEP) certification.

To secure the programming lockout jumper with a wire security seal, refer to *Wire Security Seal Installation (NTEP Seal)* on page 24.

To access and enable the programming lockout jumper:

1. Remove all the connectors.
2. Unscrew the back cover.
3. Slide the back cover about 1 inch.
4. Configure the JP1 jumper, located behind the input signal connector, for the desired programming lockout operation (lockout on or off) as shown.

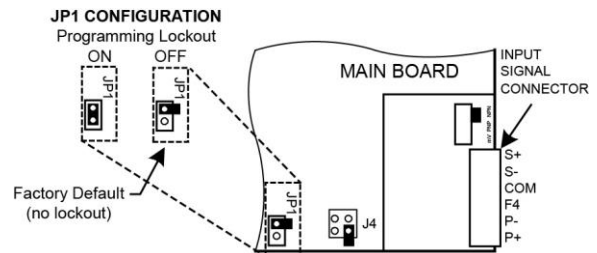

Figure 4. Programming Lockout Jumper Selection

Wire Security Seal Installation (NTEP Seal)

All controllers include mechanical features to install a wire security seal. This seal secures the rear case portion of the controller, preventing unauthorized access to the programming lockout jumper.

Combined with using the programming lockout jumper to restrict access to the programming, the controller meets the requirements for National Conference on Weights and Measures (NCWM) National Type Evaluation Program (NTEP) certification.

To enable the programming lockout jumper, refer to *Programming Lockout Jumper (NTEP Lockout)* on page 23.

Note: Refer to the document [PD8-6300 Series NTEP Certified Pulse Input Devices Security Seal Installation Guide \(LIM8-63101WM-2\)](#) for complete NTEP security seal installation instructions.

To install the wire security seal:

1. Locate the wire security seal packed with the controller.



Figure 5. Wire Security Seal and Bracket

2. Pass the wire security loop through the wire loop pass-through holes on the rear portion of the controller housing.

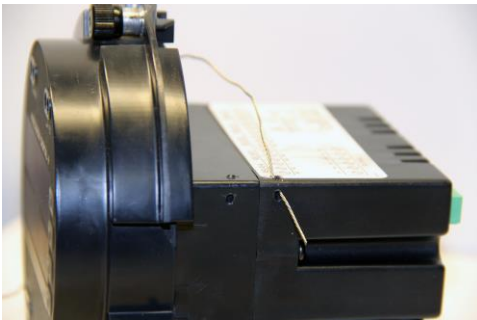

Figure 6. Wire Loop through Rear Case Pass-Through

3. Pass the wire loop through the second set of wire loop pass-through holes in the controller housing.

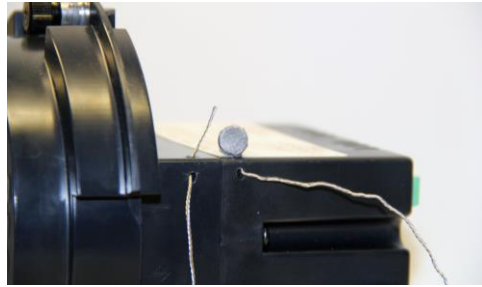
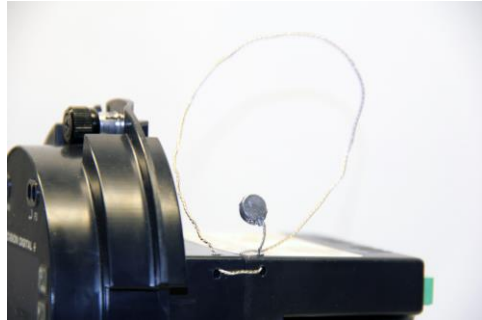

Figure 7. Wire Loop through Security Bracket Pass-Through

4. With the wire loop through the front and rear of the case, pass the loop back through the crimp seal end. Tighten the loop such that it will prevent the rear of the case from being removed while the loop is in place.



5. The wire loop may now be tagged, crimped, and sealed to mechanically secure the rear case. This will secure the programming lockout jumper.

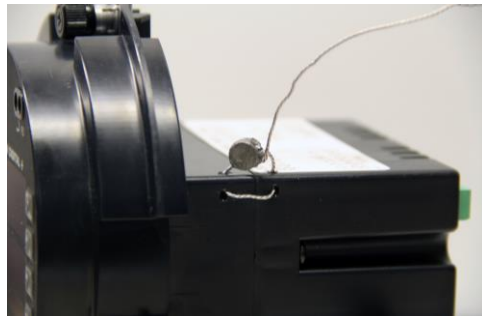

Figure 8. Close and Crimp Seal Wire Security Loop

Connections

All connections are made to removable screw terminal connectors located at the rear of the controller.

CAUTION

- Use copper wire with 60°C or 60/75°C insulation for all line voltage connections. Observe all safety regulations. Electrical wiring should be performed in accordance with all applicable national, state, and local codes to prevent damage to the controller and ensure personnel safety.

WARNINGS

- Observe all safety regulations. Electrical wiring should be performed in accordance with all agency requirements and applicable national, state, and local codes to prevent damage to the controller and ensure personnel safety.
- Static electricity can damage sensitive components.
- Observe safe handling precautions for static-sensitive components.
- Use proper grounding procedures/codes.
- If the instrument is installed in a high voltage environment and a fault or installation error occurs, high voltage may be present on any lead or terminal.
- Follow all fusing and wiring precautions requirements for the instrument integrated to the PD8 Series model number being connected.

To access the connectors, remove the enclosure cover and unscrew the two captive screws that fasten the electronics module. Signal connections are made to de-pluggable connectors on the back of the electronics module.

Some connectors may be provided already connected. These connections are required for proper operation of the ProtEX-MAX and should not be removed unless instructed to by this manual.

Wires marked as being used for testing purposes should be removed.

Grounding connections are made to the two ground screws provided on the base – one internal and one external.

After all connections have been completed and verified, apply power to the unit.

Required & Factory Wired Connection

The ProtEX-MAX comes with a pre-wired connection. This connection is detailed below and must be maintained in order for the instrument to function properly.

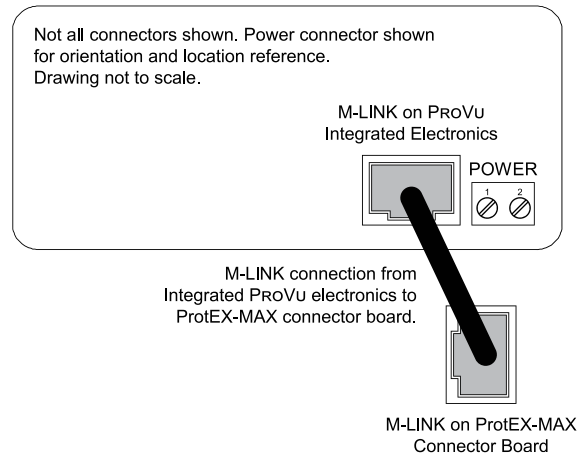

Figure 9. Integrated ProVu Required Connections

ProVu Electronics Module Layout for PD8-6310-6H7-WM and PD8-6310-7H7-WM

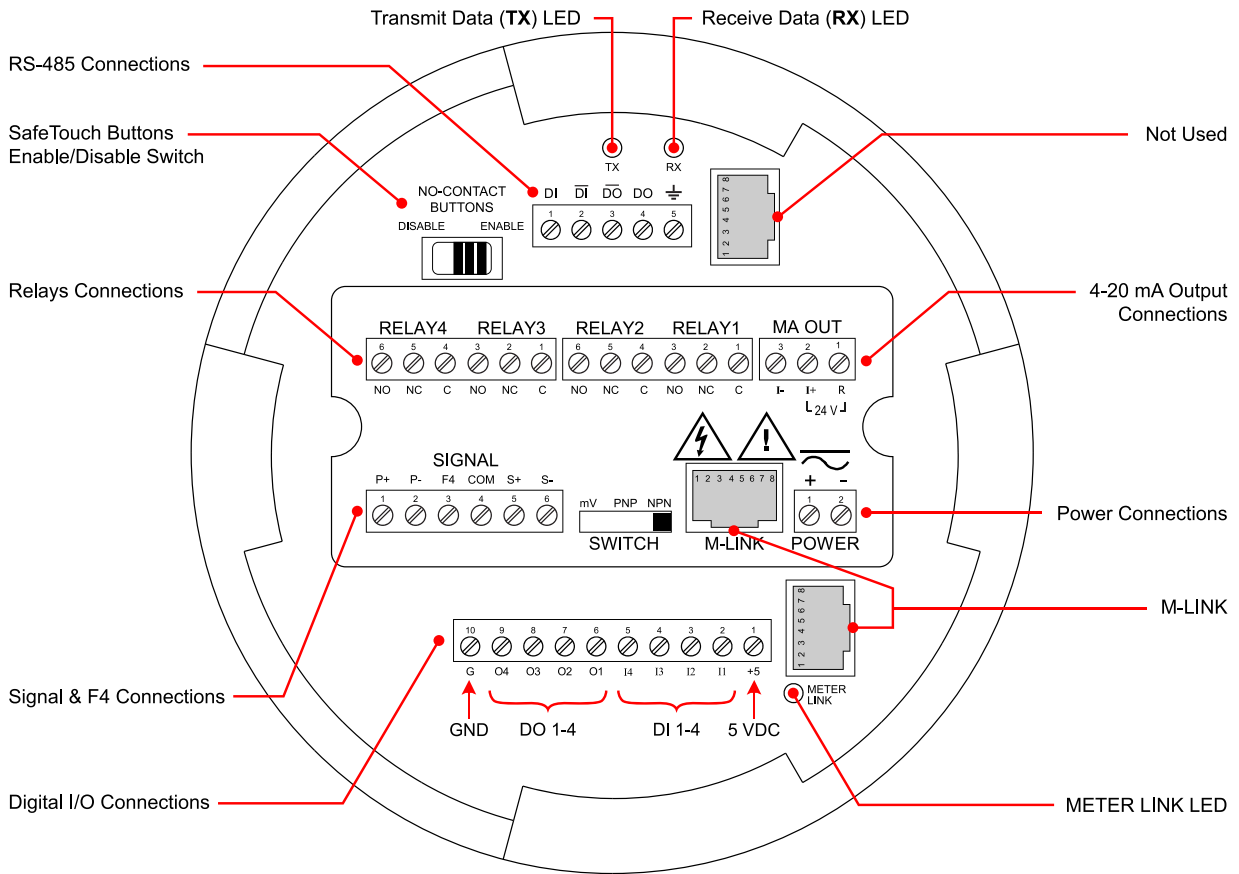

Figure 10. ProVu Electronics Module Layout

USB Connection

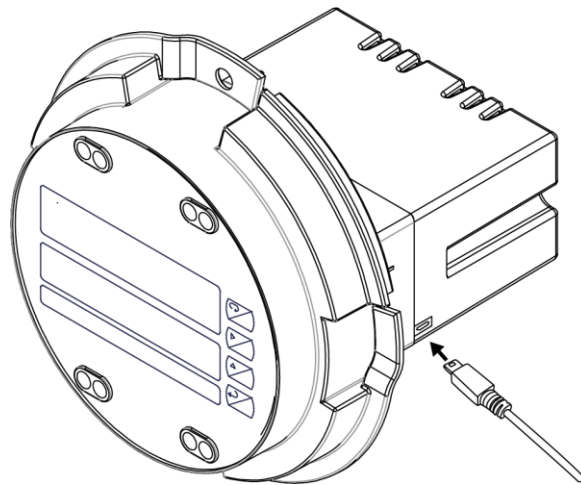

Figure 11. USB Connection

⚠ WARNINGS

- **DO NOT** disconnect the RJ45 M-LINK connector cable. Otherwise the instrument will not function properly.
- When using the USB connection, the controller should only be connected to a computer when both devices are in a non-hazardous area.

Power Connections

Power connections are made to a two-terminal connector labeled POWER. The controller will operate regardless of DC polarity connection. The + and - symbols are only a suggested wiring convention. There are separate models for low voltage and high voltage power. See *Ordering Information* on page 7 for details.

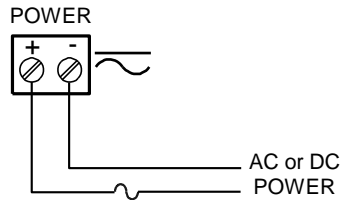

Required External Fuse:
5 A max, 250 V Slow Blow

Figure 12. Power Connections

Pulse Signal Connections

Signal connections are made to a six-terminal connector labeled SIGNAL. The COM (common) terminal is the return for the input signals.

The following figures show examples of signal connections. Setup and programming is performed through the programming buttons or MeterView Pro software.

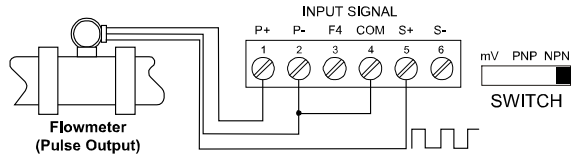

Figure 13. Flowmeter Powered by Internal Power Supply

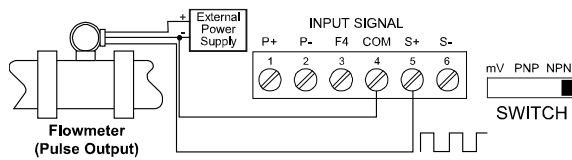

Figure 14. Flowmeter Powered by External Supply

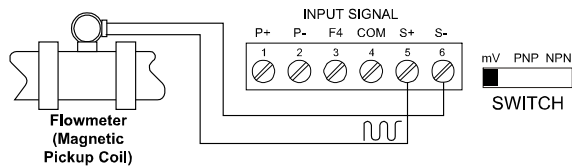

Figure 15. Self-Powered Magnetic Pickup Coil Flowmeter

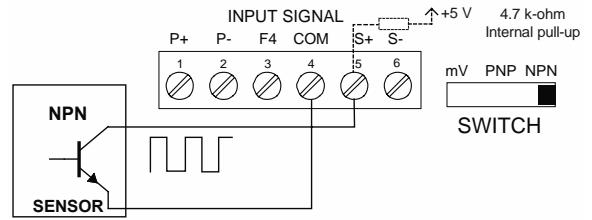

Figure 16. NPN open Collector Input

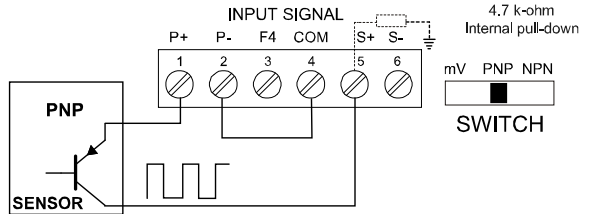

Figure 17. PNP Sensor Powered by Internal Supply

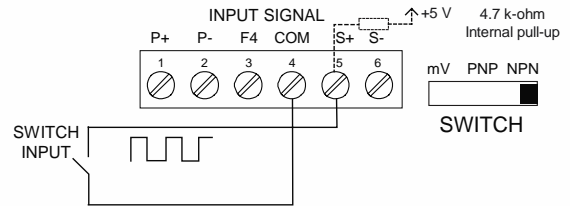

Figure 18. Switch Input Connections

Relay Connections

Relay connections are made to two six-terminal connectors labeled RELAY1 – RELAY4. Each relay’s C terminal is common only to the normally open (NO) and normally closed (NC) contacts of the corresponding relay. The relays’ C terminals should not be confused with the COM (common) terminal of the INPUT SIGNAL connector.

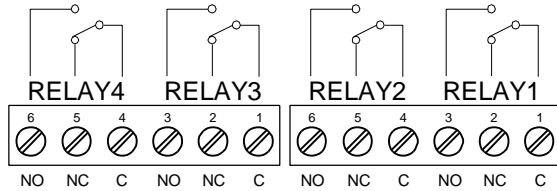

Figure 19. Relay Connections

Interlock Relay Feature

As the name implies, the interlock relay feature reassigns one, or more, alarm/control relays for use as interlock relay(s). Interlock contact(s) are wired to digital input(s) and activate the interlock relay. This feature is enabled by configuring the relay, and the corresponding digital input(s), see *Setting Up the Interlock Relay (Force On) Feature* on page 50.

In the example below, an Interlock Contact switch is connected to a digital input, which will be used to force on (energize) the Interlock Relay. The Interlock Relay and the Control Relay are connected in series with the load.

- When the Interlock Contact is closed (safe), the Interlock Relay energizes, allowing power to flow to the Control Relay; the corresponding front panel LED is on.
- When the Interlock Contact is open, the corresponding front panel LED flashes (locked out), the Interlock Relay is de-energized, preventing power from flowing to the Control Relay and the load.

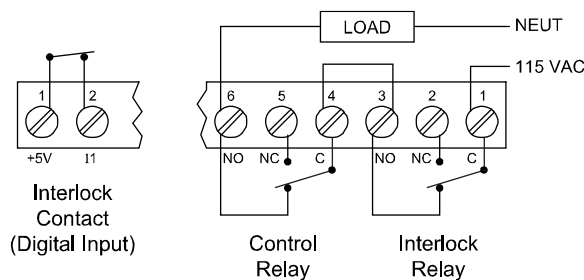

Figure 20. Interlock Connection

Switching Inductive Loads

The use of suppressors (snubbers) is strongly recommended when switching inductive loads to prevent disrupting the microprocessor’s operation. The suppressors also prolong the life of the relay contacts. Suppression can be obtained with resistor-capacitor (RC) networks assembled by the user or purchased as complete assemblies. Refer to the following circuits for RC network assembly and installation:

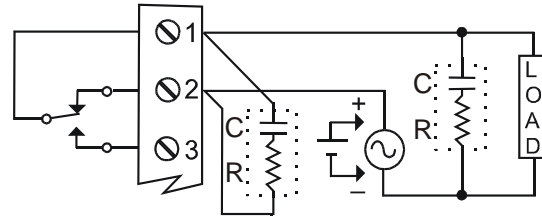

Figure 21. AC and DC Loads Protection

Choose R and C as follows:

- R: 0.5 to 1 Ω for each volt across the contacts
- C: 0.5 to 1 μF for each amp through closed contacts

Notes:

1. Use capacitors rated for 250 VAC.
2. RC networks may affect load release time of solenoid loads. Check to confirm proper operation.
3. Install the RC network at the controller’s relay screw terminals. An RC network may also be installed across the load. Experiment for best results.

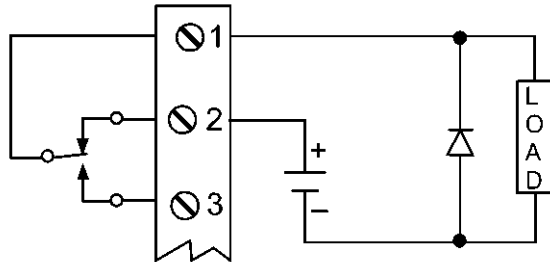

Use a diode with a reverse breakdown voltage two to three times the circuit voltage and forward current at least as large as the load current.

Figure 22. Low Voltage DC Loads Protection

RC Networks Available from Precision Digital

RC networks are available from Precision Digital and should be applied to each relay contact switching an inductive load. Part number: [PDX6901](#).

Note: Relays are de-rated to 1/14th HP (50 watts) with an inductive load.

RS-485 Connections

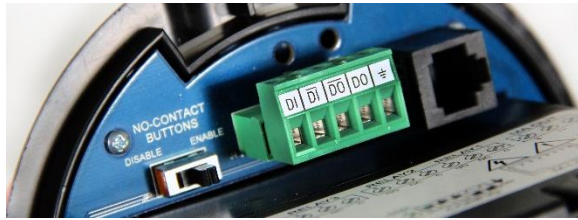

The RS-485 connections are made to a five terminal connector used for Modbus RTU serial communications. The RS-485 terminals include Transmit Data (DO) and (/DO), Receive Data (DI) and (/DI), and Signal Ground. See *Modbus RTU Serial Communications (SERIAL)* on page 61 for more information.

There are three diagnostic LEDs: Transmit Data (TX), Receive Data (RX) and METER LINK to show when the controller is transmitting and receiving data from other devices.

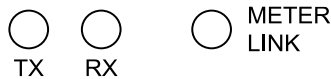

Figure 23. RS-485 Diagnostic LEDs

RS-485 Multi-Drop Connection

When using more than one controller in a multi-drop mode, each controller must be provided with its own unique address. The controller address (Slave ID) can be programmed between 1 and 247. The transmit delay can be set between 0 and 199 ms. The parity can be set to even, odd, or none with 1 or 2 stop bits.

To change the controller address:

1. Press and hold the Menu button for three seconds to access Advanced Features menu of the controller.
2. Press Up arrow until Serial (SERIAL) menu is displayed and press Enter, ADDR ES is displayed.
3. Press Enter to change controller address using Right and Up arrow buttons. Press Enter to accept.
4. Press Menu button to exit and return to Run Mode.

Three-Wire Connection

In order to wire the five pins for use as a three-wire half-duplex RS-485 connection, it is necessary to create a jumper connection between DI to DO and /DI to /DO- as shown below.

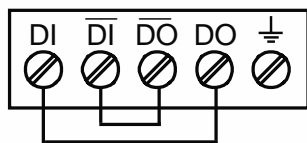
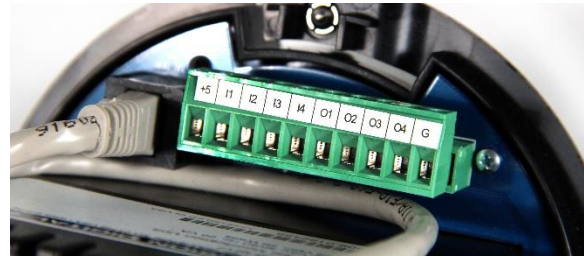

Figure 24. Three-Wire RS-485 Connection

Digital I/O Connections



The ProtEX-MAX has a 10-position terminal block for connecting digital inputs and outputs.

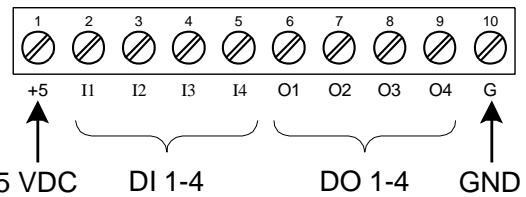

Figure 25. Digital Input and Output Connections

IMPORTANT

The onboard digital inputs (1-4) are configured at the factory to function identically to the front panel pushbuttons (Menu, F1, F2, & F3) in order to work with the SafeTouch buttons. Changing the programming of the digital inputs will affect the function of the SafeTouch buttons.

If you wish to change the behavior of the digital inputs, re-assign F1-F3 to the desired function, then change the corresponding digital input to match.

WARNING

- **DO NOT** disconnect the RJ45 M-LINK connector cable. Otherwise the instrument will not function properly.

F4 Digital Input Connections

A digital input, F4, is standard on the controller. This digital input should be connected with a normally open contact across F4 and COM, or with an active low signal applied to F4. It can be used to start/stop the batch, reset the total, acknowledge/reset relays, or to reset max/min values. See *Function Keys & Digital I/O Available Settings* on page 64 for a complete list of capabilities.

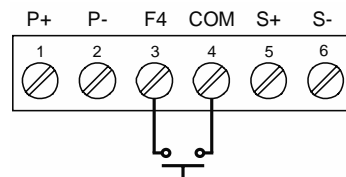

Figure 26. F4 Digital Input Connections

4-20 mA Output Connections

Connections for the 4-20 mA transmitter output are made to the connector terminals labeled MA OUT. The 4-20 mA output may be powered internally or from an external power supply.

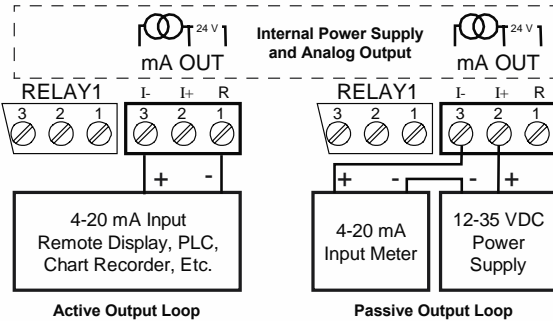

Figure 27. 4-20 mA Output Connections

Analog Output Transmitter Power Supply

The internal 24 VDC power supply powering the analog output may be used to power other devices if the analog output is not used. The I+ terminal is the +24 V and the R terminal is the return.

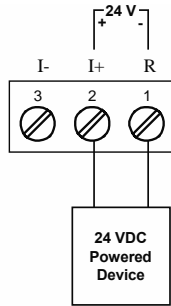
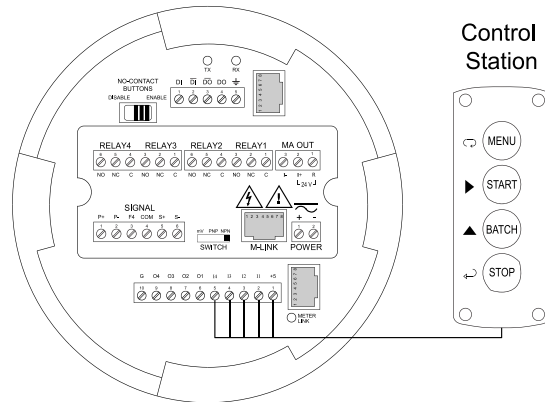

Figure 28. Analog Output Supply Powering Other Devices

Remote Programming

The controller can be operated via the programming buttons or a remote control station* with required approvals to be located in a hazardous area using the digital inputs.



* Control station must be approved for hazardous locations

Setup and Programming

The controller may either be scaled (SCALE) without applying an input, calibrated (CAL) by applying an input, or you may use the K-Factor menu to match the batch controller with a flowmeter's k-factor (pulse/unit of measure).
 The controller comes factory calibrated to NIST standards, so for initial setup, it is recommended to use the K-Factor method or (SCALE) function.

Overview

There is one switch, located to the right of the input connector, which must be configured according to the input level and type. The switch labeled P+/P- located in the center of the connections board is used to select the excitation voltage (24 V*, 10 V or 5 V) which is supplied to the P+ and P- wiring terminals.

Setup and programming is done using MeterView Pro or through the programming buttons.

After power and input signal connections have been completed and verified, apply power to the controller.





*Default setting.



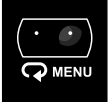

LED Status Indicators



LED	State	Indication
1-4	Steady	Alarm condition based on set and reset points, independent of relay status in certain configurations.
1-4	Flashing	Relay interlock switch open
1-4 & M	Flashing	Relay in manual control mode
R	Steady	Rate
T	Steady	Total
G & T	Steady	Grand Total
▲	Steady	Total overflow. ("oF" is displayed to the left of total overflow and ▲ LED is illuminated)
M	Flashing	Analog output in manual control mode

Programming Buttons

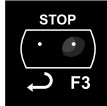
Button	Description
 	Menu
 	START Right Arrow/F1

Button	Description
 	BATCH Up Arrow/F2
 	STOP Enter/F3

- Press the Menu button to enter or exit the Programming Mode at any time.
- Press the Right arrow button to move to the next digit during digit or decimal point programming.
- Press or hold the Up arrow button to scroll through the menus, decimal point, or to increment the value of a digit.
- Press the Enter button to access a menu or to accept a setting.
- Press and hold the Menu button for three seconds to access the advanced features of the controller.

SafeTouch Buttons

The ProtEX-MAX is equipped with four sensors that operate as through-glass buttons so that it can be programmed and operated without removing the cover (and exposing the electronics) in a hazardous area.

These buttons can be disabled for security by selecting DISABLE on the switch labeled NO-CONTACT BUTTONS located on the connector board.

To actuate a button, press one finger to the glass directly over the marked button area. Then retract finger more than three inches from the glass before pressing the next button. When the cover is removed, the four mechanical buttons located next to the sensors are used. The sensors are disabled when a mechanical button is pressed and will automatically be re-enabled after 60 seconds of inactivity.

The SafeTouch Buttons are designed to filter normal levels of ambient interference and to protect against false triggering, however, it is recommended that the SafeTouch Buttons be disabled (slide switch to DISABLE) if there is an infrared interference source in line-of-sight to the display.

The SafeTouch Buttons are configured by default to duplicate the function of the front panel mechanical pushbuttons associated with the integrated controller. The symbols by each SafeTouch button correspond to a mechanical button as shown in the above table.

SafeTouch Button Tips:

- To the extent possible, install the display facing away from sunlight, windows, reflective objects and any sources of infrared interference.
- Keep the glass window clean.
- Tighten the cover securely.
- Use a password to prevent tampering.



Display Functions and Messages

The controller displays various functions and messages during setup, programming, and operation. The following table shows the main menu functions and messages in the order they appear in the menu.

Display Functions and Messages		
Display	Parameter	Action/Setting Description
ሀይትሆፕ	Setup	Enter Setup menu
ከስፖት	Input	Enter Input selection menu
ጠቅላይ	Total	Enable or disable totalizer features
ህብረት	Units	Select the display units/tags
ፍጥነት	Rate	Select the display units for rate
ጠቅላይ	Total	Select the display units for total
ጠቅላይ	Grand Total	Select the display units for grand total
ወረቀት	Decimal point	Set decimal point for rate, total, grand total
ፕሮግራም	Program	Enter the Program menu
ከስተር	Input Calibration	Enter the Input Calibration menu
ፍጥነት	K-factor Scaling	Programs unit to convert input pulse to rate in engineering units
ሀይትሆፕ	Scale	Enter the Scale menu
ክሊብሬት	Calibrate	Enter the Calibrate menu
ከስፕ 1	Input 1	Calibrate input 1 signal or program input 1 value
ወረቀት 1	Display 1	Program display 1 value
ከስፕ 2	Input 2	Calibrate input 2 signal or program input 2 value (up to 32 points)
ወረቀት 2	Display 2	Program display 2 value (up to 32 points)
ፎሎዎ	Error	Error, calibration not successful, check signal or programmed value
ጠቅላይ	Total time base	Enter totalizer time base for seconds, minutes, hours or day.
ኮንቨርሽን	Total conversion factor	Enter the conversion factor decimal point and the conversion factor.
ባች ሞድ	Batch mode	Automatic or manual batch control
ጊዜ ልዩ	Time delay	Set time delay for automatic batch restart
ጠቅላይ	Grand total time base	Program grand total time base

Display Functions and Messages		
Display	Parameter	Action/Setting Description
ጠቅላይ	Grand total conversion factor	Program grand total conversion factor
ጠቅላይ	Grand total reset	Program grand total reset mode: auto or manual
ወረቀት	Display	Enter the Display menu
ከስተር 1	Display Line 1	Press Enter to assign the Main display parameter (default: PV or rate)
ከስተር 2	Display Line 2	Press Enter to assign the Second display parameter (default: total)
ደረጃ	Display intensity	Set display intensity level from 1 to 8
ፍጥነት	Relay	Enter the Relay menu
ጠቅላይ	Assignment	Assign relays to rate, total (batch control), grand total, or Modbus controlled.
ጠቅላይ	Assign 1	Relay 1-2 assignment
ጠቅላይ	Total	Assign relay to batch control
ጠቅላይ	Grand total	Assign relay to grand total
ሞዱስ	Modbus	Assign relay to Modbus input
ፍጥነት	Rate	Assign relay to rate
ፕሮግራም	Batch total relay pre-close	For relays beyond the first assigned to total, a pre-close amount may be entered.
ፍጥነት	Relay 1	Relay 1 setup
ጠቅላይ	Action 1	Set relay 1 action ¹
ሞዱስ	Automatic	Set relay for automatic reset
ፍጥነት	Auto-manual ¹	Set relay for automatic & manual reset any time ¹ (relays assigned to rate)
ጠቅላይ	Latching ¹	Set relay for latching operation (relays assigned to rate) ¹
ጠቅላይ	Latching-cleared ¹	Set relay for latching operation with manual reset only after alarm condition has cleared (relays assigned to rate) ¹
ጠቅላይ	Alternate	Not applicable to batch controller
ፍጥነት	Sampling	Set relay for sampling operation (rate or GT)
ፎፍ	Off	Disable relay and front panel status LED (Select Off to enable Interlock feature)
ፕሮግራም	Preset	Set batch preset
ሀይት 1	Set 1	Program set point 1

Display Functions and Messages		
Display	Parameter	Action/Setting Description
rSt 1	Reset 1	Program reset point 1
rLY 2	Relay 2	Relays 2-4 setup.
FRILSF	Fail-safe	Enter Fail-safe menu
FLS 1	Fail-safe 1	Set relay 1 fail-safe operation
on	On	Enable fail-safe operation
oFF	Fail-safe off	Disable fail-safe operation
dELAY	Delay	Enter relay Time Delay menu
dLY 1	Delay 1	Enter relay 1 time delay setup
On 1	On	Set relay 1 On time delay
OFF 1	Off	Set relay 1 Off time delay
Route	Analog output	Enter the Analog output scaling menu
dS 1	Display 1	Program display 1 value
Out 1	Output 1	Program output 1 value (e.g. 4.000 mA)
dS 2	Display 2	Program display 2 value
Out 2	Output 2	Program output 2 value (e.g. 20.000 mA)
rESEt	Reset	Press Enter to access the Reset menu
rSt Hi	Reset high	Press Enter to reset max display
rSt Lo	Reset low	Press Enter to reset min display
rSt HL	Reset high & low	Press Enter to reset max & min displays
rSt t	Reset total	Press Enter to reset total
rSt Gt	Reset grand total	Press Enter to reset grand total
rSt bc	Reset batch count	Press Enter to reset batch count
Control	Control	Enter Manual Control menu
Auto	Automatic	Press Enter to set controller for automatic operation
Man	Manual	Press Enter to manually control relays or analog output operation
PR55	Password	Enter the Password menu
PR55 1	Password 1	Set or enter Password 1
PR55 2	Password 2	Set or enter Password 2
PR55 3	Password 3	Set or enter Password 3
toeRL	Total password	Set or enter password for manual reset
GeoeRL	Grand total password	Set or enter password for manual reset

Display Functions and Messages		
Display	Parameter	Action/Setting Description
nonrSt	Non-resettable	Non-resettable grand total set after entering "050873" for Gtotal password
unLoc	Unlocked	Program password to lock controller
Locd	Locked	Enter password to unlock controller
999999 -999999	Flashing display	Overrange condition Underrange condition

1. During operation, only the STOP button will function, to stop/pause the batch. As a result, relay alarms cannot be manually reset.

Main Menu

The main menu consists of the most commonly used functions: *Setup, Reset, Control, and Password.*

- Press Menu button when a batch is not running to enter Programming Mode then press the Up arrow button to scroll main menu.
- Press Menu, at any time, to exit and return to Run Mode. Changes made to settings prior to pressing Enter are not saved.
- Changes to the settings are saved to memory only after pressing Enter.
- The display moves to the next menu every time a setting is accepted by pressing Enter.

Setting Numeric Values

The numeric values are set using the Right and Up arrow buttons. Press Right arrow to select next digit and Up arrow to increment digit value. The digit being changed is displayed brighter than the rest.

Press and hold up arrow to auto-increment the display value.

Press the Enter button, at any time, to accept a setting or Menu button to exit without saving changes.

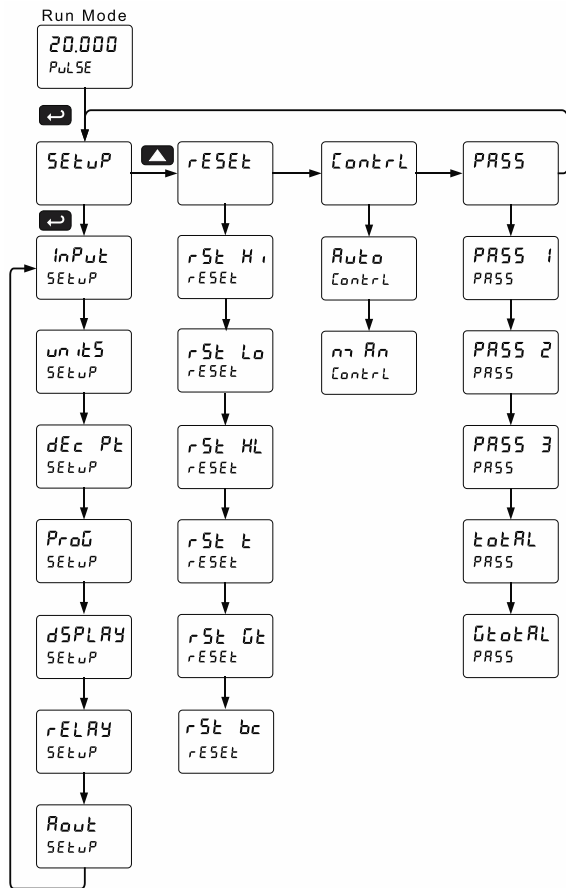
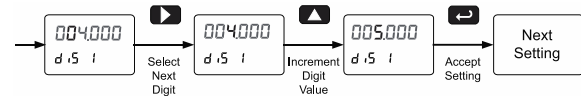

Setting Up the Batch Controller (SEtUP)

The Setup menu is used to select:

1. Input signal the controller will accept
2. Enable or disable totalizer and batching features
3. Select the display units/tags
4. Decimal point position
5. Program menu for scaling or calibration, totalizer setup, manual or automatic batch mode
6. Display parameter and intensity
7. Relay operation
8. 4-20 mA analog output scaling

Press the Enter button to access any menu or press Up arrow button to scroll through choices. Press the Menu button to exit at any time.

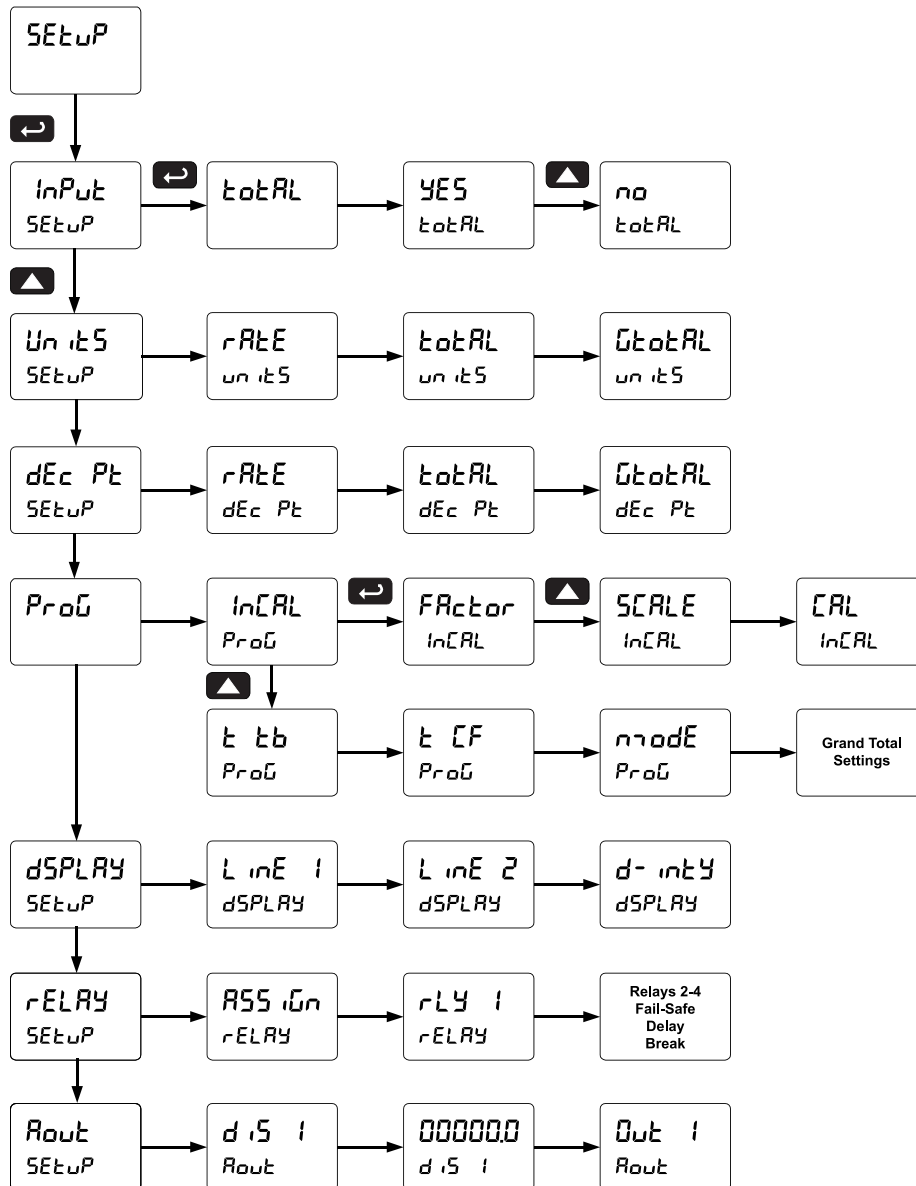

Setting the Input Signal (InPulse)

There is a switch, located to the right of the input connector, which must be configured according to the input level and type. For location of this switch, see *Pulse Signal Connections* on page 28.

Jumper J4 located inside the meter, behind the input signal connector, is used to select the excitation voltage (24 V [Default setting], 10 V or 5 V) which is supplied to the P+ and P- wiring terminals. For location of this switch, see *Controller Supply Voltage Selection (P+, P-)* on page 23.

Enter the Input menu to enable or disable the totalizer features.

The controller may be calibrated using the *K-Factor* function. Most flowmeter manufacturers provide this information with the device. Enter the *K-Factor (FRct or)* menu and select the decimal point with highest resolution possible and program the K-factor value (i.e. pulses/gal). The controller will automatically calculate the flow rate using the K-factor and the time base selected.

Setting the Totalizer & Batch Control Features (Totalize)

After the input type is entered, set the *Totalize* parameter to "YES" to enable batch control (this is set by default). If the *Totalize* features are disabled, most batching features and functions are hidden from the menus.

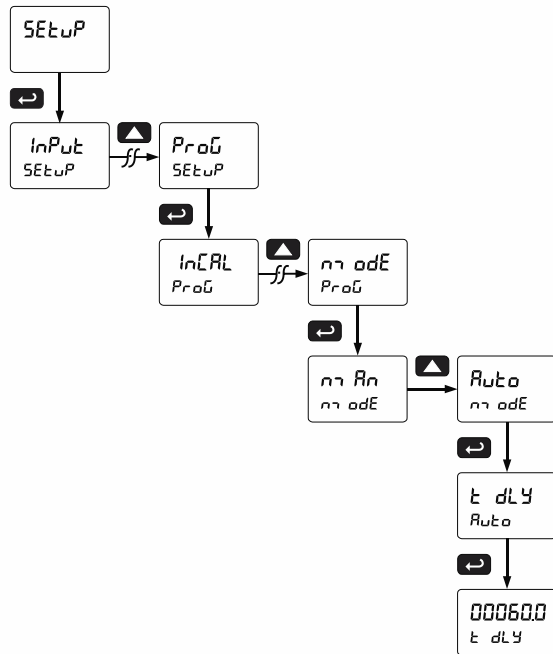

Setting the Input Units or Custom Tags (Unit)

Enter the input unit or custom tag that will be displayed if alternating rate, total, or grand total and units is selected in the *Unit* menu, or *Unit* is selected as the Second display parameter. See the *Setting the Display Parameter & Intensity (dSPLY)* flow chart on page 42 to access the display menu to show the unit or tag on the second display.

The engineering units or custom legends can be set using the following 7-segment character set:

Display	Character
0	0
1	1
2	2
3	3
4	4
5	5
6	6
7	7
8	8
9	9
A	A
b	b
C	C
c	c
d	d
E	E
F	F
G	G
g	g
H	H
h	h
I	I
i	i
J	J

Display	Character
K	K
L	L
m	m
n	n
O	O
o	o
P	P
q	q
r	r
S	S
t	t
u	u
V	V
w	w
X	X
Y	Y
Z	Z
-	-
/	/
]]
[[
=	=
Degree(<)	Degree(<)
Space	Space

Notes:

1. Degree symbol represented by (<) if programming with MeterView Pro.
2. The letters "m" and "w" use two 7-segment LEDs each; when selected the characters to the right are shifted one position.
3. Press and hold up arrow to auto-scroll the characters in the display.

Setting the Decimal Point (dE c Pt)

The decimal point may be set with up to five decimal places or with no decimal point at all. The rate, total, and grand total decimal points are independent.

The decimal point selection should be made prior to scaling, calibrating or programming the controller.

Press the Up arrow to move the decimal point one place to the left. Press the Right arrow to move the decimal point one place to the right.

Programming the Batch Controller (Prog)

The controller may either be scaled (SCALE) without applying an input, calibrated (CAL) by applying an input, or you may use the K-Factor menu to match the rate/totalizer with a flowmeter's k-factor (pulse/unit of measure). The controller comes factory calibrated to NIST standards, so for initial setup, it is recommended to use the (SCALE) function.

The Program menu contains the following menus:

1. Input Calibration
 - a. Enter K-Factor
 - b. Scale without a signal source
 - c. Calibrate with a signal source
2. Total time base & conversion factor
3. Batch mode
 - a. Manual batch control
 - b. Automatic batch control
4. Grand total time base & conversion factor
5. Grand total reset mode
 - a. Manual reset
 - b. Automatic reset with time delay

The process inputs may be calibrated or scaled to any display value within the range of the controller.

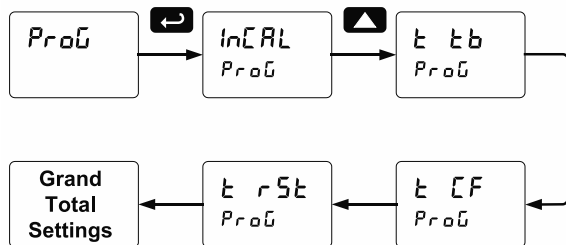

Additional parameters, not needed for most applications, are programmed in the Advanced Features menu; see Advanced Setup & Programming on page 59.

Input Calibration Method (InCAL)

There are three methods of calibrating (or scaling) the display to show the correct engineering units.

- Use the Factor menu to enter a K-Factor
- Use the Scale menu to enter the scaling without a signal source.
- Use the Calibrate menu to apply a signal from a signal source.

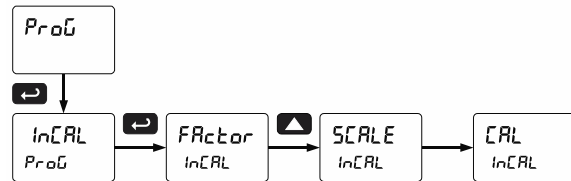

IMPORTANT

- The Scale, Calibrate, and K-Factor functions are exclusive of each other. The controller uses the last function programmed. Only one of these methods can be employed at a time.
- The Scale and Calibrate functions can use up to 32 points (default is 2). The number of points should be set in the Advanced menu prior to scaling and calibration of the controller. See Multi-Point Linearization (LnERr) menu on page 62 for details.

K-Factor Calibration (FRct or)

The controller may be calibrated using the K-Factor function. Most flowmeter manufacturers provide this information with the device. Enter the K-Factor (FRct or) menu and select the decimal point with highest resolution possible and program the k-factor value (i.e. pulses/gal). The controller will automatically calculate the flow rate using the k-factor and the time base selected.



Scaling the Controller (SCALE)

The pulse inputs can be scaled to display the process variable in engineering units.

A signal source is not needed to scale the controller; simply program the inputs and corresponding display values.

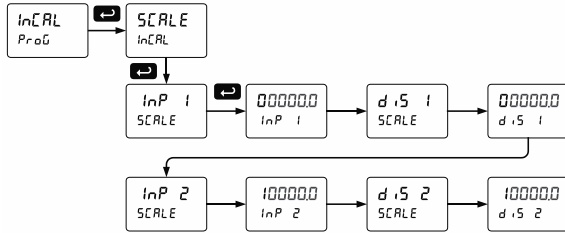

Note: The display values (d,5 1 and d,5 2) need to be in units of measure per second. For example, if the rate at 1000 Hz is 13.20 gal/min, this must be converted to gal/sec. In this scenario, the numbers input into the SCALE menu would be as follows:

- InP 1: 0.0
- d,5 1: 0.00
- InP 2: 1000.0
- d,5 2: 0.22

For instructions on how to program numeric values see *Setting Numeric Values*, page 36.

Error Message (Error)

An error message indicates that the calibration or scaling process was not successful.

After the error message is displayed, the controller reverts to input 2 during calibration or scaling and to input 1 during internal calibration, allowing the appropriate input signal to be applied or programmed.

The error message might be caused by any of the following conditions:

1. Input signal is not connected to the proper terminals or it is connected backwards.
2. Wrong signal selection in *Setup* menu.
3. Minimum input span requirements not maintained.
4. Input 1 signal inadvertently applied to calibrate input 2.

Minimum Input Span

The minimum allowed input span is 0.10 Hz, which is the minimum difference between input 1 and input 2 signals required to complete the calibration or scaling of the controller.

Time Base, Total Conversion Factor & Total Reset

The time base, total conversion factor, and total reset menus are located in the *Program* menu.

The total and grand total have their own independent settings. This means that one can be displaying the value in gallons while the other displays in million gallons, liters, m³, etc.

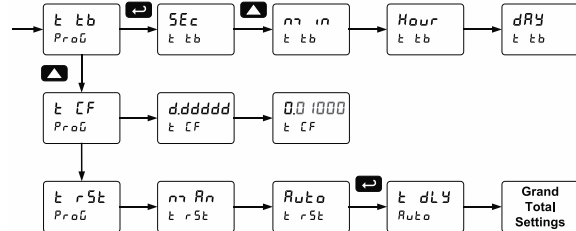

Time Base

The time base is the amount of time over which the rate parameter should accrue. For example, if the rate was ten and the time base was in minutes, then the total would increase by ten every one minute.

Total & Grand Total Conversion Factor

The total & grand total conversion factor is the amount by which the rate is multiplied before it is added to the total or grand total.

For Example, if the rate was 10,000 gallons per minute and the total conversion factor was 0.001, the total would increase by 10 every minute. This is useful, for instance, if you want to show rate in gallons and total in thousands of gallons.

Batch Start Mode (הרסדע)

Manual Batch Control

The batch controller may operate in manual or automatic mode. In manual mode, the controller operates as described in *Manual Batch Control* on page 55.

Automatic Batch Control

In automatic mode, the controller operates as described in *Automatic Batch Control* on page 56.

The batch process will start when the operator presses the START button and it will automatically restart after a completed batch. The time delay for the restart may be 0.1 to 999.9 seconds (ע דל צ).

Automatic batch start will only occur after a successful batch. A manually stopped batch will require a manual start to begin a new batch process.

Grand Total Reset

The grand total can be programmed for manual or automatic reset. In the automatic reset mode, a programmable time delay is available to reset the grand total after the assigned preset is reached.

The totals can also be reset via the front panel button, via a switch across the F4 terminal, digital inputs, or via a Modbus command.

Non-Resettable Totalizer

The grand total can be programmed as a non-resettable total, see *Grand Total Reset Password & Non-Resettable Total* on page 52 for details.

Calibrating the Controller with External Source (ערל)

The controller can be calibrated to display the process variable in engineering units by applying the appropriate input signal and the corresponding display value.

The use of a calibrated signal source is strongly recommended to calibrate the controller.

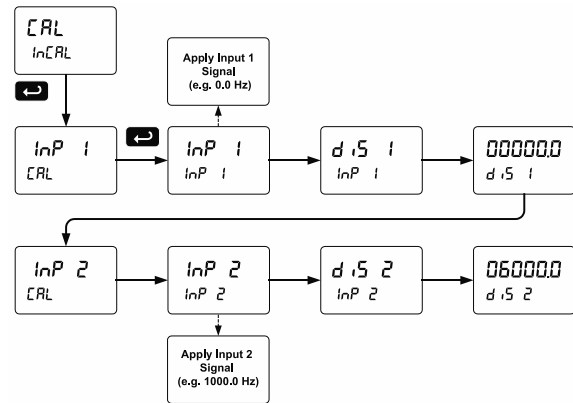

Notes:

1. The display values (d,5 1 and d,5 2) need to be in units of measure per second.
2. Inputs for the above example are:
Input 1: 0.0 Hz; Display 1: 0.0 gallons/sec
Input 2: 1000.0 Hz; Display 2: 6000.0 gallons/sec
3. After completing the calibration, you can change the time base to /min, /hour, or /day.

Warm up the controller for at least 15 minutes before performing calibration to ensure specified accuracy.

Setting the Display Parameter & Intensity (dSPLY)

Display line 1 (LINE 1) can be programmed to display:

1. Display total
2. Display grand total
3. Toggle rate and total
4. Toggle rate and grand total
5. Display batch count
6. Relay set points
7. Toggle preset and rate
8. Toggle rate and units
9. Toggle total and units
10. Toggle grand total and units
11. Display max and min values
12. Display Modbus input
13. Display rate value

Display line 2 (LINE 2) can be programmed to display:

1. Toggle rate and units
2. Toggle total and units
3. Toggle grand total and units
4. Display max and min values
5. Display Modbus input
6. Off (no display)
7. Display rate units
8. Display rate
9. Display total
10. Display grand total
11. Toggle rate and total
12. Toggle rate and grand total
13. Display batch count
14. Relay set points
15. Toggle preset and rate

After setting up the input and the display, press the Menu button to exit programming and skip the rest of the setup menu. Press the Menu button again and the Up arrow to reach the Program menu and complete the scaling or calibration of the controller.

Display Menu

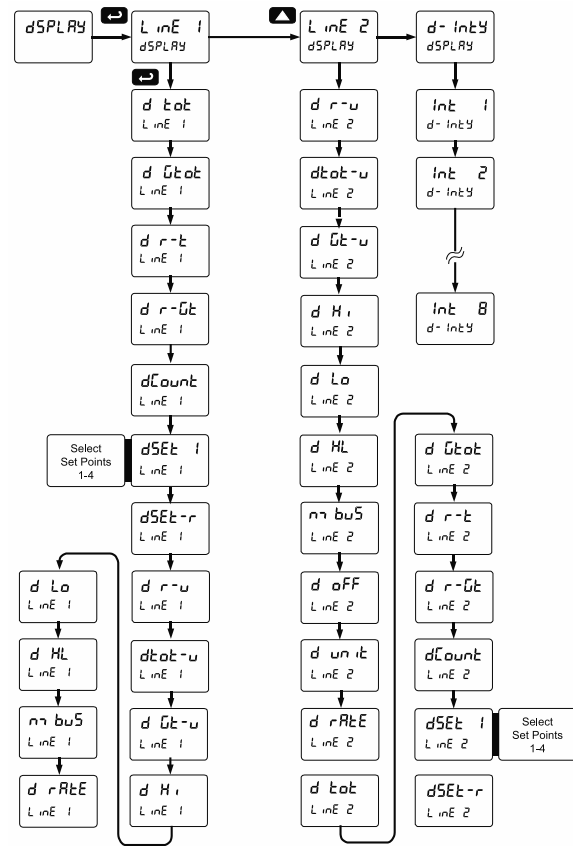

Display Intensity (d- IntY)

The controller has eight display intensity levels to give the best performance under various lighting conditions. Select intensity 8 for outdoor applications. The default intensity setting is 6.

For direct sunlight readability, Sunbright display models are highly recommended. See *Ordering Information* on page 7 for details.

Display Configurations

The main and second displays may be assigned to rate, total, grand total, batch count, preset, set points, units (second display only), alternating R & T, R & GT, preset & rate, max & min, or a Modbus display register. Any rate/total/grand total display may be programmed to alternate with a custom unit or tag. The default display configuration consists of a main display of batch total and a second display of the batch preset.

The display can also be set up, so batch total is on the main display and rate is on the second display.



Batch Total and Preset



Batch Total and Rate

Setting the Relay Operation (rELAY)

This menu is used to set up the operation of the relays.

CAUTION

- During setup, the relays do not follow the input and they will remain in the state found prior to entering the Relay menu.

1. Relay assignment
 - a. Rate for low and high alarm
 - b. Total for batch control relays
 - c. Grand total for grand total alarms
2. Relay action
 - a. Automatic reset only (non-latching)
 - b. Automatic + manual reset when not in a batch process (non-latching)
 - c. Latching (manual reset when not in a batch process only)
 - d. Latching with Clear (manual reset when not in a batch process only after alarm condition has cleared)
 - e. Pump alternation control (Not applicable to batch control)
 - f. Sampling (the relay is activated for a user-specified time and may be assigned to rate or grand total)
 - g. Off (relay state can be controlled by Interlock feature)

3. Set and reset points; batch preset
4. Fail-safe operation
 - a. On (enabled)
 - b. Off (disabled)
5. Time delay
 - a. On delay (0-999.9 seconds)
 - b. Off delay (0-999.9 seconds)

Note: Fail-safe should not be used for relays assigned to batch control.

CAUTION

- The rate alarms are active only during a batch process. As a result, rate alarms should not be programmed with manual reset, as they cannot be manually reset during a batch process, the only time they are active.

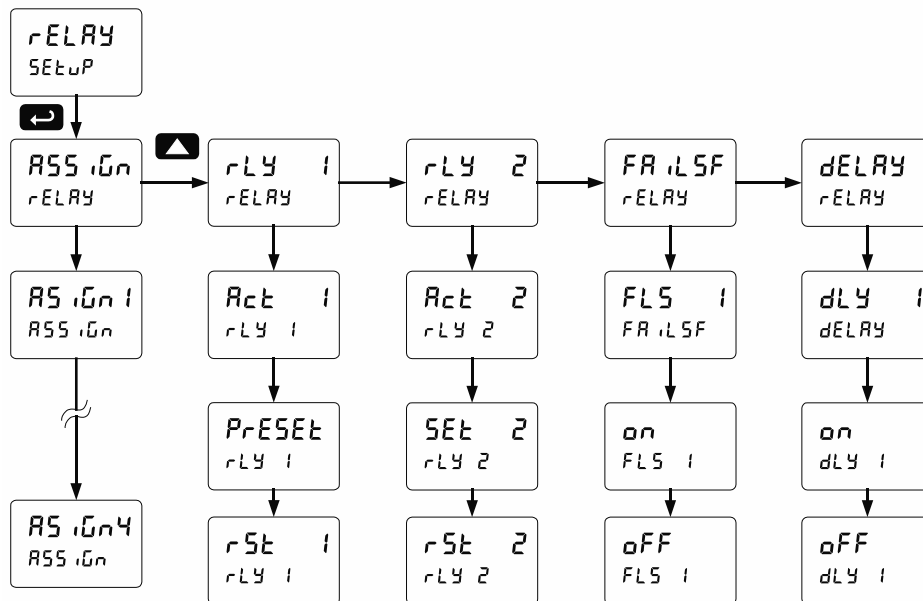

Note: The setup of relays 3-4 follows the same pattern shown here for relay 2.

Relay Assignment (R55 iGn)

The relays can be assigned to any of the following parameters:

1. Rate for low or high alarm indication
2. Total for batch control relays
3. Grand total for alarm indication or sampling

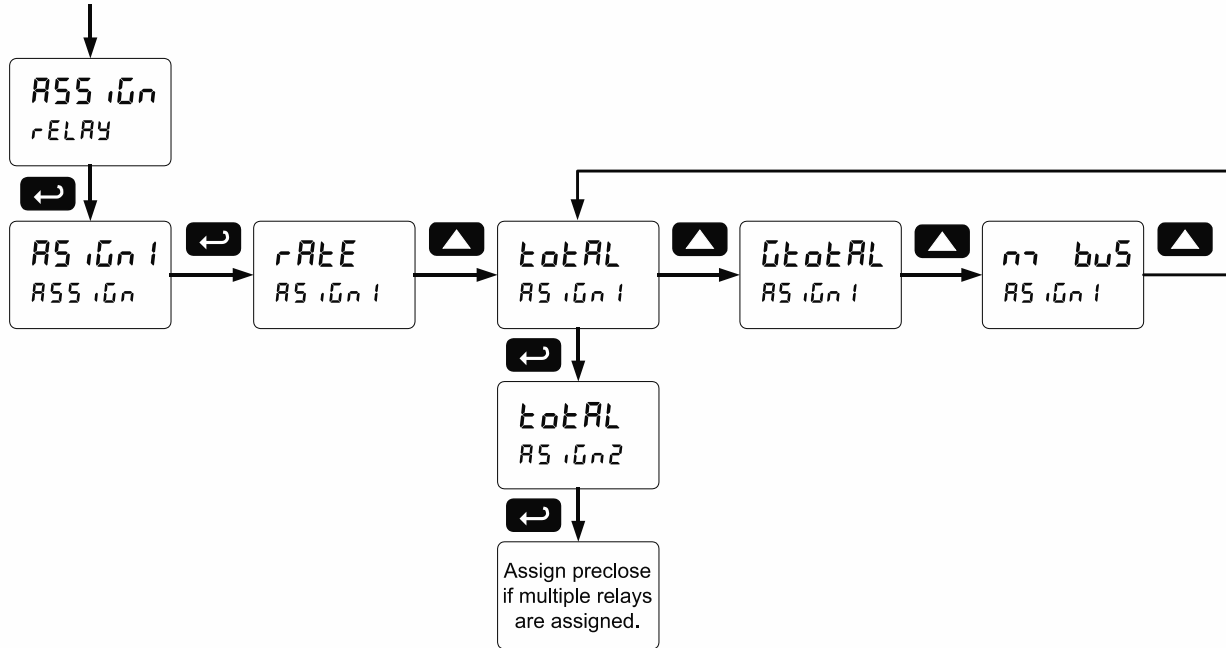

▲ IMPORTANT

- Relay 1 should always be assigned to “total” for batch control applications.

Setting the Relay Action

Operation of the relays is programmed in the *Action* menu. The relays are commonly set up for any of the following modes of operation:

1. Always set to Auto for Batch control operation. Also for automatic reset (non-latching) of alarms.
2. Sampling (the relay is activated for a user-specified time)
3. Off (relay state can be controlled by Interlock feature)

In addition, the following relay actions may be programmed. These actions are not appropriate for batch control applications but may be used when the controller is in other applications.

4. Automatic + manual reset when not in a batch process (non-latching)
5. Latching (manual reset only, when not in a batch process)
6. Latching with Clear (manual reset only when not in a batch process after alarm condition has cleared)
7. Pump alternation control (not applicable to batch control)

Setting Batch Control Relays

Operation of batch control relays are programmed in the *Assign* menu by selecting *to RL* as the assignment. Relays set to *to RL* beyond the first relay will include a pre-close parameter (*PRECLS*) option. Selecting *YES* for *PRECLS* will enable multi-stage batching with pre-close, and the valve will close prior to the end of the batch at volume equal to the preset value minus the pre-close amount entered. Selecting *no* for *PRECLS* will have the relay perform identically to the first batch control relay set to *to RL*.

Programming Alarm Set and Reset Points

High alarm: program set point above reset point.

Low alarm: program set point below reset point.

The deadband is determined by the difference between set and reset points. Minimum deadband is one display count. If the set and reset points are programmed with the same value, the relay will reset one count below the set point.

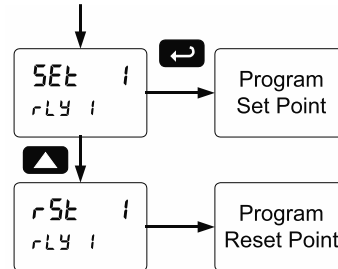

Note: Changes are not saved until the reset point has been accepted.

Setting Fail-Safe Operation

In fail-safe mode of operation, the relay coil is energized when the process variable is within safe limits and the relay coil is de-energized when the alarm condition exists. The fail-safe operation is set independently for each relay. Select *on* to enable or select *off* to disable fail-safe operation. Failsafe mode should not be used on batch relays assigned to total.

Programming Time Delay

The *On* and *Off* time delays may be programmed for each relay between 0 and 999.9 seconds. The relays will transfer only after the condition has been maintained for the corresponding time delay.

The *On* time delay is associated with the set point.

The *Off* time delay is associated with the reset point.

Automatic Batch Control Operation

The following graph shows automatic batch operation.

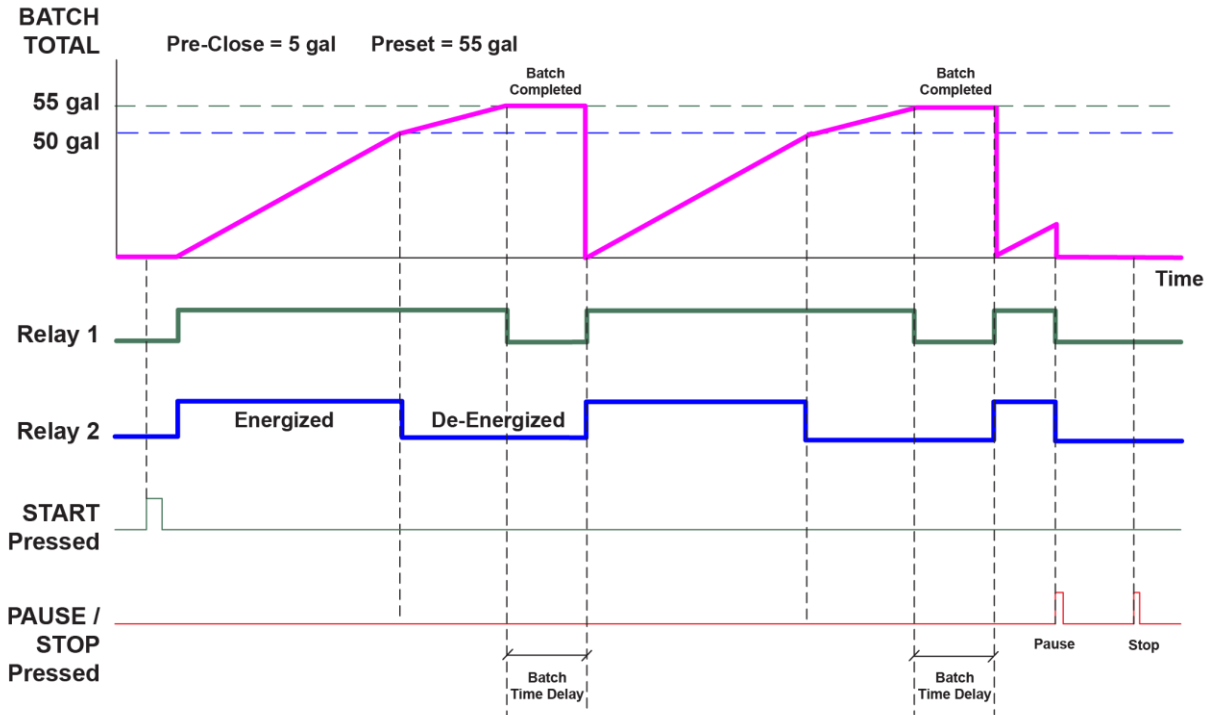

When START is pressed, a short delay occurs before the low flow alarm sensing is activated. Each relay can be programmed with additional ON delay to satisfy various conditions and applications.

1. START button is pressed
2. Both relays are energized opening both valves controlling the flow
3. At 50 gallons (pre-close = 5 gal), relay 2 closes the main valve
4. At 55 gallons (preset = 55 gal), relay 1 closes the dribble valve
5. After the Batch Time Delay elapses, a new batch starts automatically without the operator's intervention.

Relay and Alarm Operation Diagrams

The following graphs illustrate the operation of the relays, status LEDs, and ACK button.

High Alarm Operation (Set > Reset)

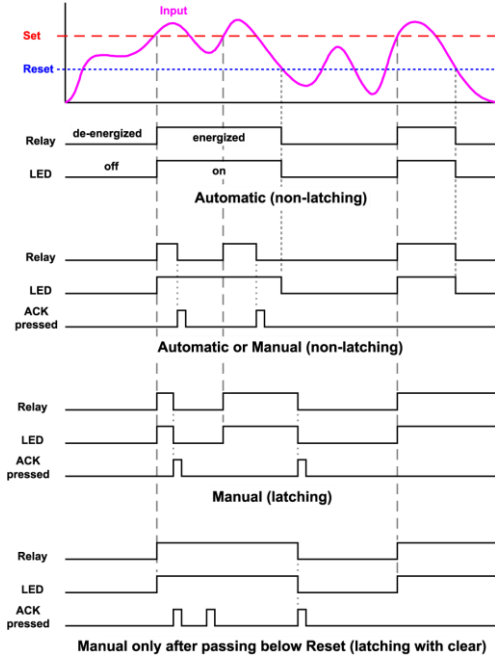

For Manual reset mode, ACK can be pressed anytime to turn "off" relay. To detect a new alarm condition, the signal must go below the set point, and then go above it.

Low Alarm Operation (Set < Reset)

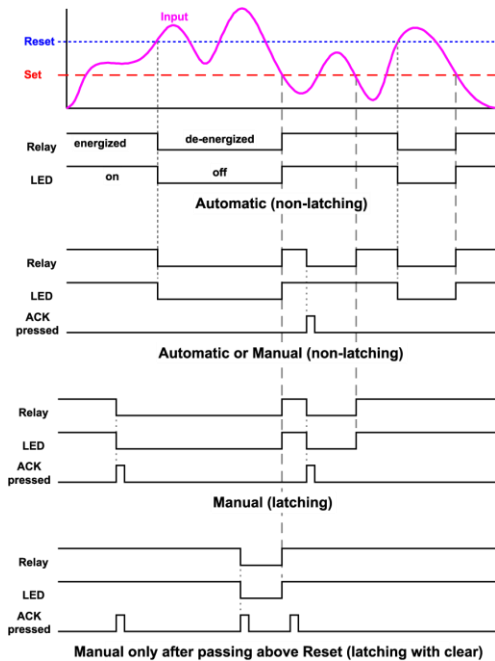

For Manual reset mode, ACK can be pressed anytime to turn "off" relay. To detect a new alarm condition, the signal must go below the set point, and then go above it.

High Alarm with Fail-Safe Operation (Set > Reset)

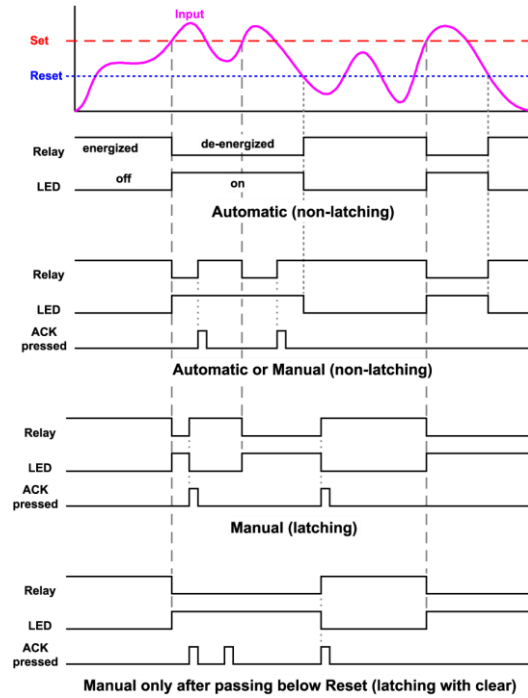

Note: Relay coil is energized in non-alarm condition. In case of power failure, relay will go to alarm state.

Low Alarm with Fail-Safe Operation (Set < Reset)

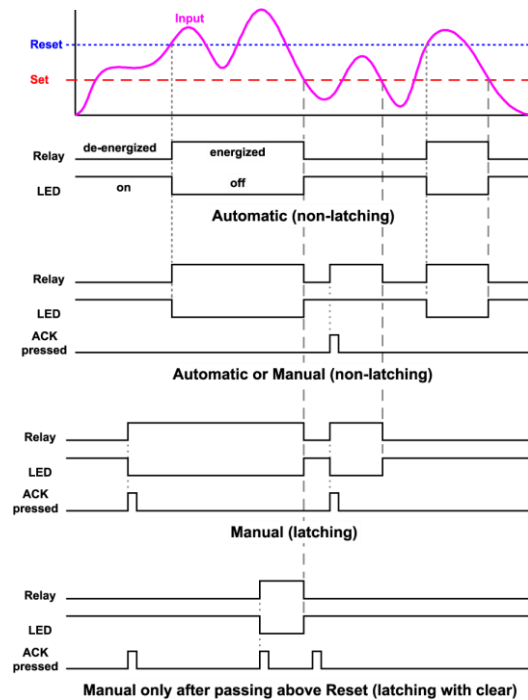

Note: Relay coil is energized in non-alarm condition. In case of power failure, relay will go to alarm state.

Time Delay Operation

The following graphs show the operation of the time delay function.

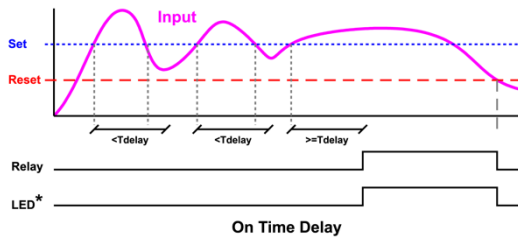

On Time Delay

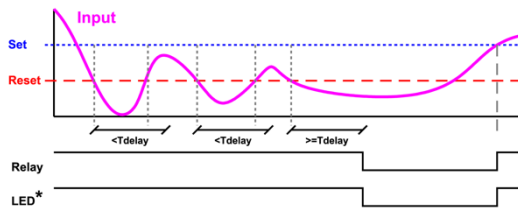

Off Time Delay

When the signal crosses the set point, the *On* time delay timer starts and the relay trips when the time delay has elapsed. If the signal drops below the set point (high alarm) before the time delay has elapsed, the *On* time delay timer resets and the relay does not change state. The same principle applies to the *Off* time delay.

Note: If "Automatic or Manual (R-n-Rn)" reset mode is selected, the LED follows the reset point and not the relay state when the relay is acknowledged.

Total Relay Sampling Operation

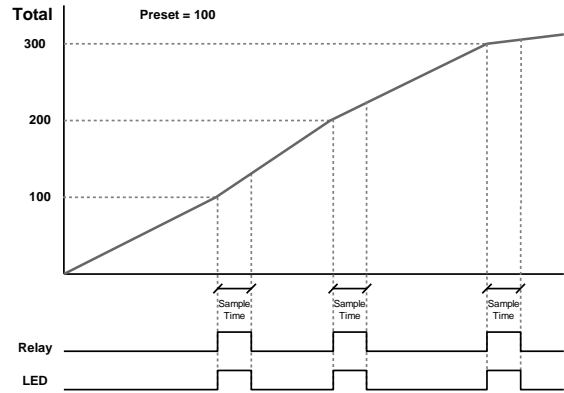

When the total reaches the preset, the relay trips and the sample time starts. After the sample time has elapsed, the relay resets. The cycle repeats every time the preset value is added to the total.

Relay Operation Details

Overview

The relays of the controller can serve three roles, as batch control relays for single or multi-stage batching, as rate, or grand total alarm, or as a sampling relay based on grand total or rate alarm.

These capabilities include front panel alarm status LEDs and 4 relays.

The relays used for batch control (total) are activated when the batching process starts and deactivate when the batch total is reached. The relays assigned as pre-close are deactivated when the batch reaches the preset value minus the pre-close value.

For an example of batch control operation, see *Batch Control Operation Example* on page 54.

Typical applications for alarms are low flow and high flow alarms or grand total limit alarms. Note that rate alarms are only activated during a batch process and deactivated when the process is stopped.

The relays can also be set for sampling, where the relay will activate for a specific amount of time after a certain grand total has been reached (e.g. 10 seconds sample relay activation every 100 gallons batched).

There are three basic ways the relays can be used:

1. Batch Control (Total)
2. High or Low Alarms for Rate or Grand Total
3. Sampling (Based on Grand Total and Sample Time)

Relays Initialization

Batch control (total) relays will activate when the start function is enabled, such as when the START button is pressed. Rate alarm relays will enable and initialize to their programmed states when the batch process is started. Grand total alarm relays will initialize to their programmed state at controller power-up.

Fail-Safe Operation

The following table indicates how alarm relays behave based on the fail-safe selection for each relay:

Fail-Safe Selection	Non-Alarm State		Alarm State		Power Failure
	NO	NC	NO	NC	
Off	Open	Closed	Closed	Open	Relays in de-energized state
On	Closed	Open	Open	Closed	Relays in energized state

Note: NO = Normally Open, NC = Normally Closed. This refers to the condition of the relay contacts when the power to the controller is off.

Front Panel LEDs

The alarm status LEDs on the front panel are available on all controllers and provide status indication for the following:

LED	Status
1	Batch Relay 1
2	Batch Relay 2
3	Low Flow Alarm
4	High Flow Alarm

The controller is supplied with alarm points that include front panel LEDs to indicate alarm conditions. This standard feature is particularly useful for alarm applications that require visual-only indication. The LEDs are controlled by the set and reset points programmed by the user. When the display reaches a set point for a high or low alarm, the corresponding alarm LED will turn on. When the display returns to the reset point the LED will go off. Note that rate alarms are only activated during a batch process, and they are deactivated when the process is stopped.

Latching relays, or relays with manual reset, are not recommended when using this controller for batch control, as the manual reset will not be acknowledged during a batch process, when the rate alarms are active. For information on latching and manual reset alarms, see the [PD8-6300](#) instruction manual.

Automatic Reset (Rulo)

In this application, the controller is set up for automatic reset (non-latching relay). Acknowledging the alarm while it is still present has no effect on either the LED or the relay. When the alarm finally goes away, the relay automatically resets, and the LED also goes off.

Automatic reset only		
Condition	LED	Relay
Normal	Off	Off
Alarm	On	On
Ack (No effect)	On	On
Normal	Off	Off

Pump Alternation Control

Pump alternation control is not recommended when using this controller for batch control, as it is used only in level applications, and not with rate, total, or batching applications.

Sample Relay Operation

The sampling function allows the operator to set a set point for a “sampling” relay. This can be done for the rate, total, or grand total. Each time the relay reaches the set point, it will close that relay’s contacts for a programmed period set by the user.

A rate sampling relay will activate for the sample time (SRNT), every time the set point rate is reached.

A total sampling relay will activate for the sample time (SRNT), every time the process has batched the amount programmed for the set point (See the diagrams on page 48 more details). The utility of this function can, of course, be expanded beyond sampling and be used whenever a timed relay output closure is required after the batch total interval reaches a certain set point.

Setting Up the Interlock Relay (Force On) Feature

Relays 1-4 can be set up as interlock relays. To set up the relays for the interlock feature:

1. Access the *Setup – Relay – Action* menu and set the action to off.

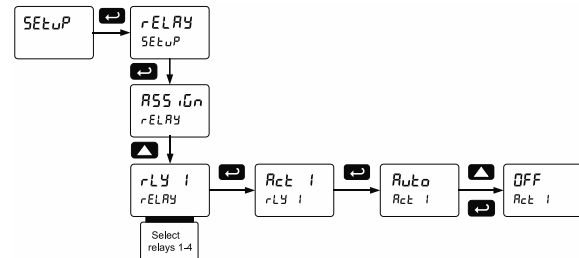

2. In the *Advanced features – User* menu program any of the digital inputs to Force On any of the internal relays (1-4).

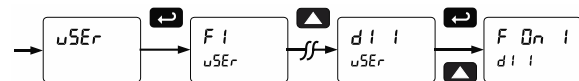

3. Connect a switch or dry contact between the +5 V terminal and the corresponding digital input (di-1 to di-4) terminal.

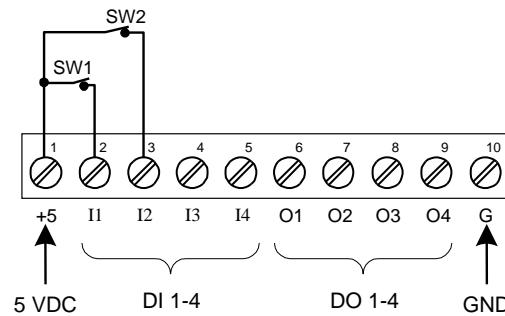

Interlock Relay Operation Example

Relays 3 & 4 are configured to energize (their front panel LEDs are steady on) when SW1 & SW2 switches (above) are closed. If the contacts to these digital inputs are opened, the corresponding front panel LEDs flash indicating this condition. The processes being controlled by the interlock relay will stop, and will re-start only after the interlock relay is re-activated by the digital inputs (switches).

Note: If multiple digital inputs are assigned to the same relay, then the corresponding logic is (AND) – i.e. both switches must be closed to activate the relay.

IMPORTANT

- If the digital inputs are assigned to the *Interlock Function*, then they cannot be used to program the controller remotely.

Scaling the 4-20 mA Analog Output (Rout)

The 4-20 mA analog output can be scaled to provide a 4-20 mA signal for any rate display range selected. No equipment is needed to scale the analog output; simply program the display values to the corresponding mA output signal.

The *Analog Output* menu is used to program the 4-20 mA output based on rate display values.

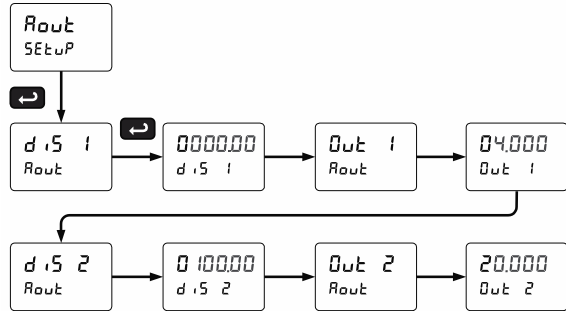

For further details, see *Setting Numeric Values* on page 36.

Reset Menu (rESEt)

The *Reset* menu is used to reset the total, grand totals, batch count, maximum, or minimum reading (peak or valley) reached by the process; both maximum and minimum may be reset at the same time by selecting "reset high & low" (rSEt HL).

Manual Control Menu (Control)

The *Manual Control* menu is used to control the 4-20 mA analog output and the relays manually, ignoring the input. Each relay and analog output can be programmed independently for manual control. Selecting automatic control sets all relays and analog output for automatic operation.

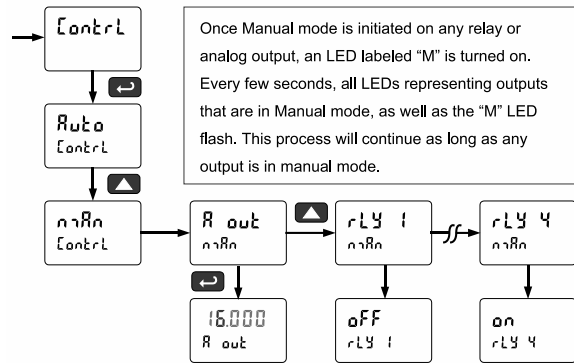

Setting Up the Password (PR55)

The *Password* menu is used for programming three levels of security to prevent unauthorized changes to the programmed parameter settings and to program the non-resettable totalizer.

- Pass 1: Allows use of function keys and digital inputs
- Pass 2: Allows use of function keys, digital inputs and editing set/reset points
- Pass 3: Restricts all programming, function keys, and digital inputs.
- Total Password: Prevents resetting the total manually
- Gtotal Password: Prevents resetting the grand total manually

Protecting or Locking the Controller

Enter the *Password* menu and program a six-digit password. For instructions on how to program numeric values see *Setting Numeric Values*, page 36.

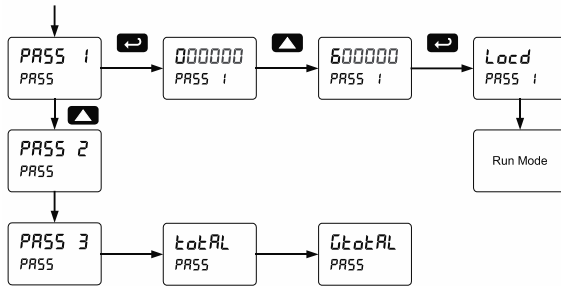

Grand Total Reset Password & Non-Resettable Total

The grand total can be password-protected to prevent unauthorized total resets.

The grand total can be programmed as a non-resettable total by entering the password "050873".

CAUTION

- Once the Grand Total has been programmed as "non-resettable" the feature **CANNOT** be disabled.

Making Changes to a Password Protected Controller

If the controller is password protected, the controller will display the message *Locd* (*Locked*) when the Menu button is pressed. Press the Enter button while the message is being displayed and enter the correct password to gain access the menu. After exiting the programming mode, the controller returns to its password protected condition.

Disabling Password Protection

To disable the password protection, access the *Password* menu and enter the correct password twice, as shown below. The controller is now unprotected until a new password is entered.

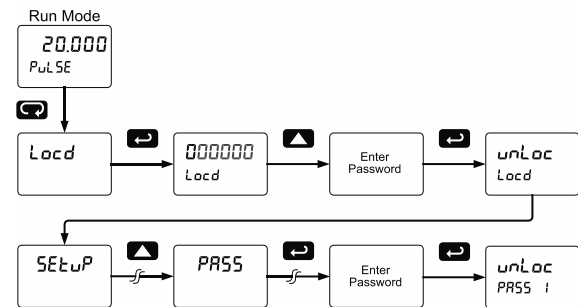

If the correct six-digit password is entered, the controller displays the message *unLoc* (*unlocked*) and the protection is disabled until a new password is programmed.

If the password entered is incorrect, the controller displays the message *Locd* (*Locked*) for about two seconds, and then it returns to Run Mode. To try again, press Enter while the *Locked* message is displayed.

Did you forget the password?

The password may be disabled by entering a master password once. If you are authorized to make changes, enter the master password 508655 to unlock the controller.

Controller Operation

When installed, the primary way to operate the controller is with the SafeTouch through-glass buttons that allow the user to perform various operations without removing the cover and exposing the electronics to the hazardous environment. The user can also operate the controller by connecting a hazardous area-approved control station or switch to one of the digital inputs. These can be used to perform various operations on the controller based on the Programmable Function Keys. Finally, certain operations can be performed on the controller with MeterView Pro software or through Modbus commands.

The three default operations that can be performed with the controller's SafeTouch buttons are:





1. Set the batch size
2. Start the batch
3. Pause/Stop the batch

In addition, the user can program the SafeTouch Buttons to perform a variety of useful operations by reassigning them to other functions per *Function Keys & Digital I/O Available Settings* on page 64.

Watch Batch Control Video at www.predig.com/videos/KN6Y6R010E

Button Operation

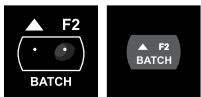
The following table shows the default operations for the F1, F2, and F3 SafeTouch Buttons: setting the batch size, starting the batch, and stopping the batch.

Button Symbol	Description
	Press to enter or exit Programming Mode or view settings
	Press to start the batch or other function assigned through the User menu
	Press to set the batch size or other function assigned through the User menu
	Press to pause/stop the batch or other function assigned through the User menu



To learn more about SafeTouch buttons, see this video: predig.com/videos/Safetouch_Buttons

SafeTouch Buttons

The ProtEX-MAX is equipped with four sensors that operate as through-glass buttons so that it can be programmed and operated without removing the cover (and exposing the electronics) in a hazardous area.

These buttons can be disabled for security by selecting DISABLE on the switch labeled NO-CONTACT BUTTONS located on the connector board.



To actuate a button, press one finger to the glass directly over the marked button area. Then retract finger more than three inches from the glass before pressing the next button. When the cover is removed, the four mechanical buttons located next to the sensors are used. The sensors are disabled when a mechanical button is pressed and will automatically be re-enabled after 60 seconds of inactivity. The SafeTouch Buttons are designed to filter normal levels of ambient interference and to protect against false triggering, however, it is recommended that the SafeTouch Buttons be disabled (slide switch to DISABLE) if there is an infrared interference source in line-of-sight to the display.

The SafeTouch Buttons are configured by default to duplicate the function of the front panel mechanical pushbuttons associated with the integrated controller. The symbols by each SafeTouch button correspond to a mechanical button as shown in the table to the left.

SafeTouch Button Tips:

- To the extent possible, install the display facing away from sunlight, windows, reflective objects and any sources of infrared interference.
- Keep the glass window clean.
- Tighten the cover securely.
- Use a password to prevent tampering.

Default Batch Control Operation

The following describes the operation of the three front panel operating keys as programmed with default settings.

START Button

Press the START button to begin a new batch process. Press the START button to resume a batch that has been stopped.

BATCH Button

Press the Batch button to access the Preset (batch amount) menu. Program the batch with the arrow keys, and confirm with the Enter key.

STOP Button

Press the STOP button once during a batch to pause. Press the STOP button while paused to stop and cancel the batch. Press the STOP button while in stop/ready mode to cycle the second display parameters: preset, grand total, and batch count (or other parameter assigned to the second display).

WARNING

- **Only STOP Button Enabled if a Batch is Running.** During a batch process, only the pause/stop functions are operational, other buttons are deactivated.

Batch Control Operation Example

The following example shows how two-stage batch control functions with a PD8-6310-WM. This setup will establish a 55-gallon preset for the batch, with a main valve (high flow) that will close at 50 gallons, and a trickle valve (low or restricted flow) that will close at 55 gallons. After the batch, the next container will hold 80 gallons, so the preset will be changed to 80.

Two-Stage Batch Control Setup Using Relays 1 & 2

The following table shows the parameters as they appear within the SETUP menu entry RELAY.

Parameter	Setting	Function
RELAY	R55,GRN	Press Enter to enter the relay assignment parameters.
R5,GRN1	toTRL	Assign relay 1 to batch total control.
R5,GRN2	toTRL	Assign relay 2 to batch total control.
PRECL5 toTRL		Press Enter to access pre-close selection for multi-stage control.
PRECL5	YES	Yes, to enable a pre-close value for relay 2.
YES	000050	Set the pre-close value to 5 to close the valve being controlled by relay 2 so it closes five gallons before reaching the preset.
...		Assignment for relays 3-4.
RELAY 1 RELAY		Select relay 1 setup.
ACT 1 RELAY 1		Configure activation of relay 1.
ACT 1	AUTO	Always set to Auto for batch control function.
RELAY 1	PRESET	Set the preset value for batch control.
PRESET	000550	Set 55 gallons as the preset.
...		Setup for relays 3-4.

The operation of relay 2 has already been assigned for multi-stage control pre-close and will not appear as a selection in the RELAY menu.

If only single stage batch control with one relay for control is desired, set the assignment of relay 2, R5,GRN2, to off, rate, or grand total.

The following pages show an illustration of how the above settings control the batch operation. The display assignment shown is the default.

Manual Batch Control

The manual batch control feature is used for batch processes where each batch must be started by the operator. The following diagrams demonstrate a typical manual batch operation with an optional hazardous area-approved remote control station. The batch could also be controlled using the through-glass buttons on the controller.

Manual Batch Control Operation

1. System Setup

Both valves are closed with an empty barrel in place. The batched total is displayed in the main display, the preset is selected for the second display.

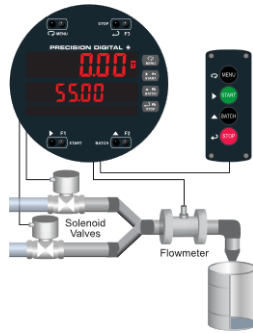

2. Batch Start

The START button is pressed. Both valves open. The barrel begins to fill.

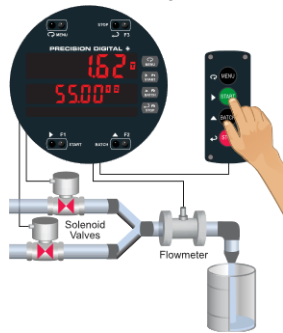

3. Preclose Valve

When the batch total reaches a value of 50.00 (Preset [55.00] – Pre-close [5.00]) the full-flow valve closes. The fill rate of the tank slows as a result.

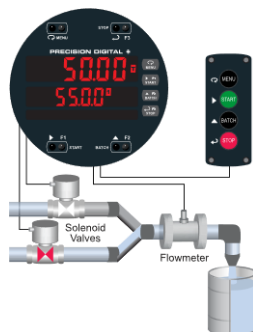

4. Completed Batch

When the batch is complete, the restricted-flow valve closes. If overrun occurs, then the next batch will adjust for this offset amount to maintain accuracy.

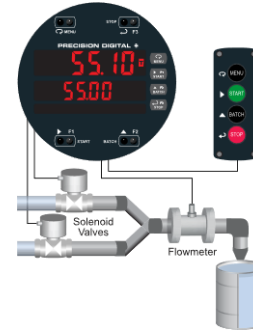

5. Change Preset

After placing a new, empty barrel, a new preset fill amount may be selected with the Batch key, while the process is stopped.

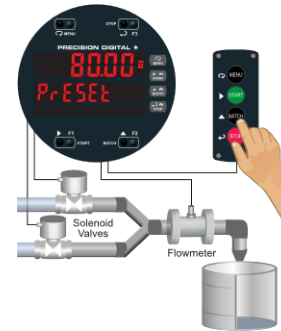

6. Begin New Batch

The new batch begins when the START button is pressed, causing both relays to activate and both valves to open.

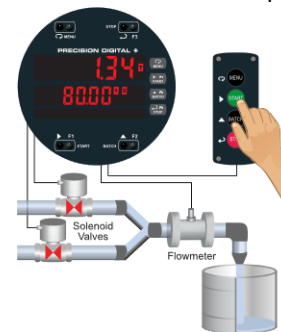

Additional Features

Pause Batch

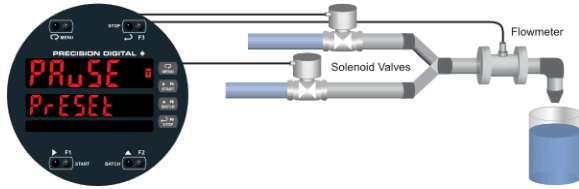

At any time during the batch, the STOP button may be pressed to pause the process.

Stop Batch

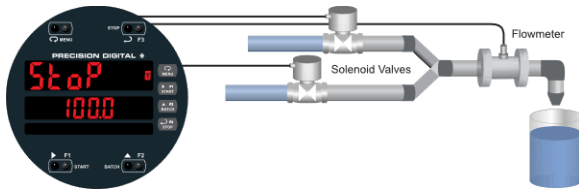

When paused, pressing the START button will continue the batch, and pressing the STOP button again will cancel the batch.

STOP Mode



When in STOP mode, the STOP button may be pressed to cycle through alternative parameters to be displayed on the second display, including the grand total, batch count, and preset.

Reset

The grand total and batch count may be reset in the rESEt menu by pressing the MENU button and entering the reset menu. It may also be reset with digital inputs.

Automatic Batch Control

The automatic batch control feature is used for batch processes where the batch size does not change, or the operator wants the next batch to start automatically after the previous batch is complete. The following diagrams demonstrate a typical automatic batch operation.

Setup for Automatic Batch Control

The batch controller can be configured to automatically start a new batch after the selected time delay between batches has elapsed.

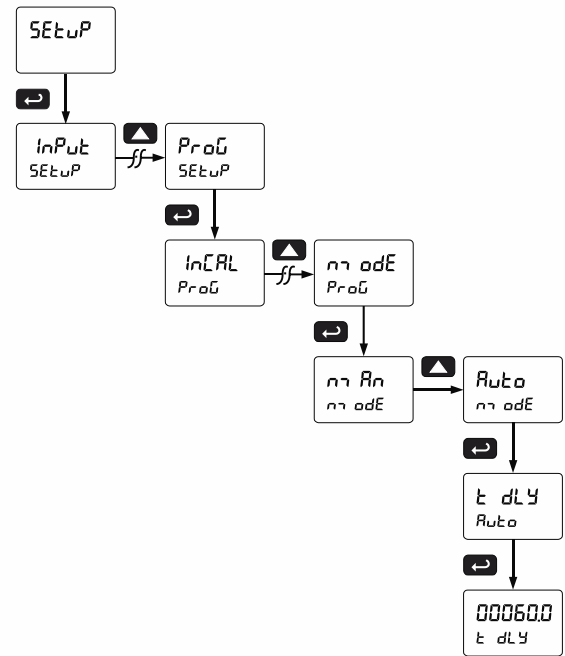

The time delay allows time for removing the full barrel and putting an empty barrel in place. Once the process starts, the operator does not have to press any buttons; except to pause or stop the batch process.

Automatic Batch Control Operation

1. System Setup

Both valves are closed with an empty barrel in place. The batched total is displayed in the main display, the preset is selected for the second display. The batch could also be controlled using the through-glass buttons on the controller.

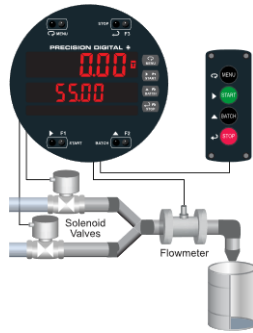

2. Batch Start

The START button is pressed. Both valves open. The barrel begins to fill.

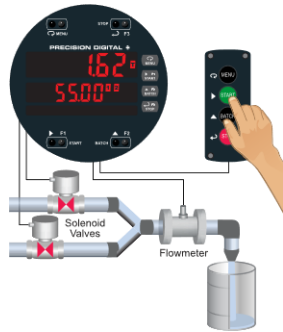

3. Preclose Valve

When the batch total reaches a value of 50.00 (Preset [55.00] – Pre-close [5.00]) the full-flow valve closes. The fill rate of the tank slows as a result.

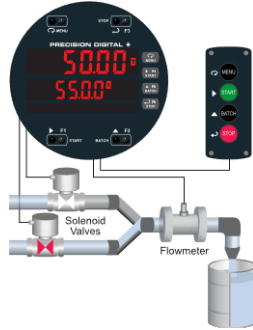

4. Completed Batch

When the batch is complete, the restricted-flow valve closes. If overrun occurs, then the next batch will adjust for this offset amount to maintain accuracy.

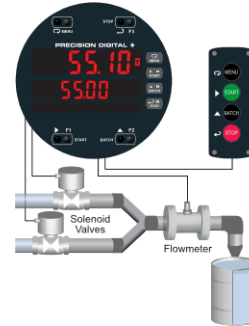

5. Replace Full Barrel with Empty Barrel

After the batch is completed, the operator removes the full barrel and places an empty barrel; the new batch starts automatically after a user-defined time delay of 60 seconds (Time Delay).

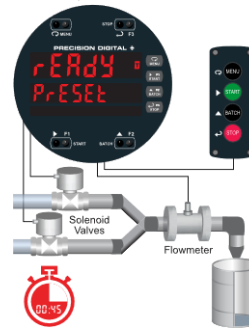

6. Begin New Batch

The new batch begins automatically after 60 seconds, both relays activate and both valves open.

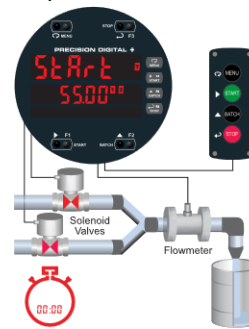

7. Stop Batch

At the end of the shift, press STOP twice to stop the batch process.

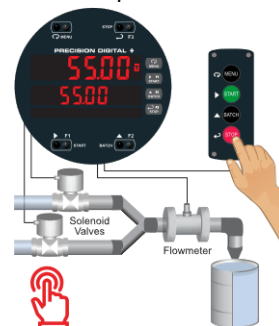

Setup with MeterView Pro

Use MeterView Pro software to set up the batch controller for manual or automatic batch control, count up or count down operation, and set the batch preset and pre-close values.

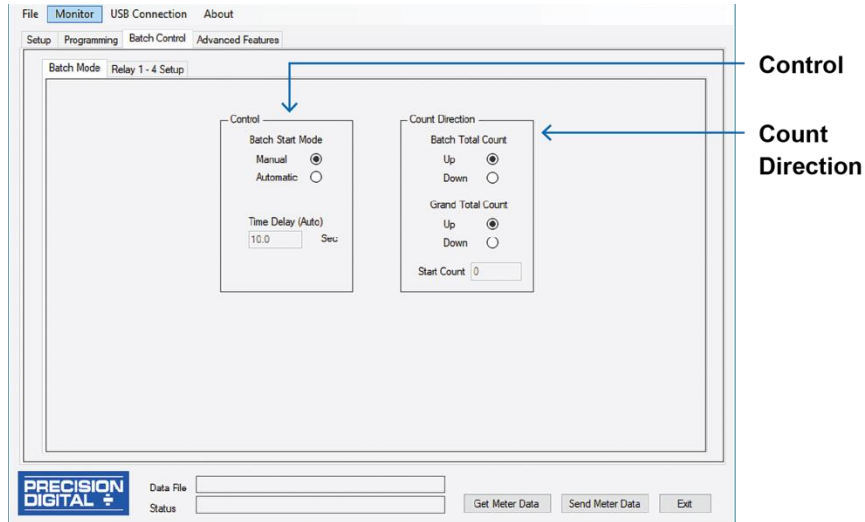

Control

Program for automatic or manual batch operation and set time delay if automatic mode.

Count Direction

Program the batch controller to count up or count down and set a starting count value if desired.

Operate with MeterView Pro

MeterView Pro software also shows the Batch Size and Current Batch Total as well as allowing the user to start and stop the batch.

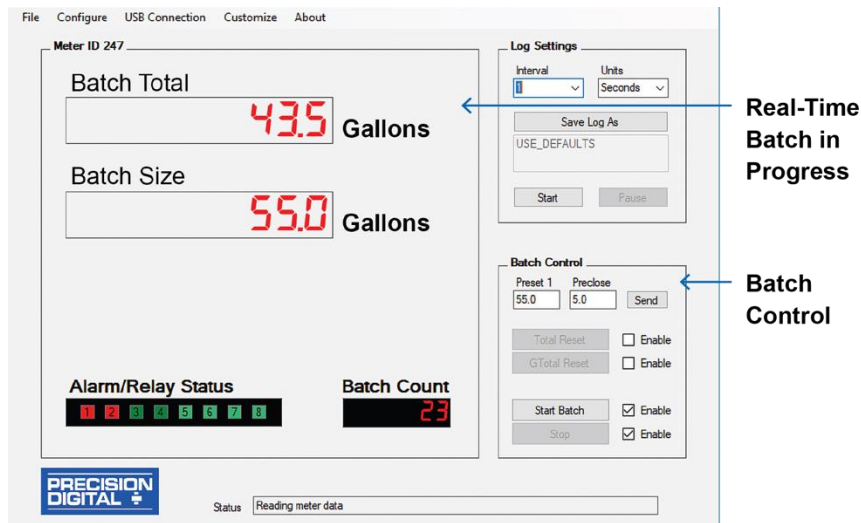

Real-Time Batch in Progress

MeterView Pro software shows all the important batch-control information.

Batch Control

MeterView Pro allows the user to set preset 1 and preclose values and start and stop the batch

Advanced Setup & Programming

In addition to the functions described in *Controller Operation* on page 53, the following advanced operation and display features may be programmed. Please note that configuring these features may disable some default batch controller features or it can make running a batch operation impossible. These functions should only be used by users who are sure of their need in their application.

Advanced Features Menu

To simplify the setup process, functions not needed for most applications are located in the *Advanced Features* menu.

Press and hold the Menu button for three seconds to access the advanced features of the controller. This cannot be done during a batch process as all functions other than STOP are disabled during a batch process, including the Menu button.

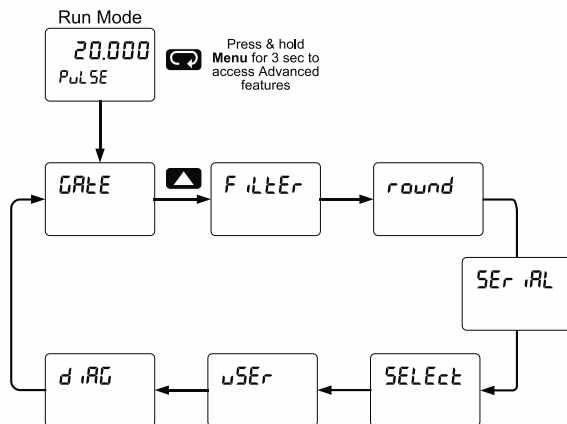

Advanced Features Menu & Display Messages

The following table shows the functions and messages of the *Advanced Features* menu in the order they appear in the menu.

Advanced Features Menu & Display Messages		
Display	Parameter	Action/Setting
GATE	Gate	Gate settings
Lo G	Low Gate	Program low gate value
Hi G	High Gate	Program high gate value
FILTER	Filter	Set noise filter value
Hi SPd	High Speed Filter	Program High Speed Filter
Lo SPd	Low Speed Filter	Program Low Speed Filter
round	Round	Set the rounding value for display variables

Advanced Features Menu & Display Messages		
Display	Parameter	Action/Setting
SERIAL	Serial	Set serial communication parameters
SLAVE ID	Slave ID	Set slave ID or controller address
baud	Baud rate	Select baud rate
tr dLY	Transmit delay	Set transmit delay for serial communication
PRr tLY	Parity	Select parity Even, Odd, or None with 1 or 2 stop bits
t-bytE	Time byte	Set byte-to-byte timeout
SELEct	Select	Enter the Select menu (function, cutoff, out)
FunctiOn	Input Signal Conditioning	Select linear
L inERr	Linear	Set controller for linear function and select number of linearization points
no PtS	Number of points	Set controller for 2 to 32-point linearization
CutOFF	Cutoff	Set low-flow cutoff
Count	Count	Set the totals to count up or down from a set value
tot C	Total count	Set the batch to count up to or down from the preset
uP	Up	Set the total to count up
doun	Down	Set the total to count down
Gtot C	Grand total count	Set the grand total to count up or down from a defined value
C StEt	Count start	Set the starting grand total value when counting down
RoutPr	Analog output programming	Program analog output parameters
SourcE	Source	Select source for the 4-20 mA output
U-r RnG	Overrange	Program mA output for display overrange
u-r RnG	Underrange	Program mA output for display underrange
ForcE	Force output	Force analog output value for loop break
IgnorE	Ignore	Ignore loop break condition
maxR	Maximum	Program maximum mA output allowed
minR	Minimum	Program minimum mA output allowed
CRl b	Calibrate	Calibrate 4-20 mA output (internal reference source used for scaling the output)
4 mR	4 mA output	Enter mA output value read by milliamp meter with at least 0.001 mA resolution
20 mR	20 mA output	Enter mA output value read by milliamp meter with at least 0.001 mA resolution

Advanced Features Menu & Display Messages		
Display	Parameter	Action/Setting
u5Er	User I/O	Assign function keys and digital I/O
F1	F1 function key	Assign F1 function key
F2	F2 function key	Assign F2 function key
F3	F3 function key	Assign F3 function key
F4	F4 function	Assign F4 function (digital input)
d11	Digital input 1	Assign digital input 1 – 4
d01	Digital output 1	Assign digital output 1 – 4
dRG	Diagnostics	Display parameter settings
LEd t	LED test	Test all LEDs
Inf o	Information	Display software number and version
ErRSE	Erase	Erase MeterView Pro software stored in controller's memory

Function Keys Operation

During operation, the programmable function keys operate according to the way they have been programmed in the *Advanced Features – User* menu. See *Programmable Function Keys User Menu (u5Er)* on page 64 for details. The following table shows the default setting for each of the function keys.

Function Key/Button	Default Setting	Action
F1/START	StRr t	Start batch
F2/BATCH	PrE5Et	Change preset
F3/STOP	St oP	Pause/stop batch
F4/Digital Input	St tStP	Start/stop batch

Digital Inputs Operation

Five (5) digital inputs, F4, DI-1 to DI-4, come standard on the controller. These digital inputs are programmed identically to function keys F1, F2, and F3. The inputs are triggered with a contact closure to +5 V in the case of digital inputs 1-4 or with an active high signal, see on page 30 for details. The F4 is triggered with a contact closure to COM or with an active low signal. During operation, digital inputs operate according to the way they are programmed in the *Advanced Features – User* menu. See *Programmable Function Keys User Menu (u5Er)* on page 64 for details.

CAUTION

- **Only STOP Operation Enabled if a Batch is Running.** During a batch process, the only function that can be performed is the pause/stop functions of the STOP button; the default programming of the F3 key. No other functions, including min/max display, manual alarm reset, or total reset, will function while a batch is running.

Advanced Setup and Calibration

Multi-Point Calibration & Scaling

The controller is set up at the factory for 2-point linear calibration. The number of points for multi-point calibration/scaling is set up in the *Advanced Features* menu. Up to 32 linearization points may be selected. See *Multi-Point Linearization (LINE)* on page 62 for details.

Maximum/Minimum Readings

The max & min readings (peak & valley) reached by the process can be displayed either continuously or momentary:

1. Display briefly by assigning to the digital inputs in the *User* menu.
2. Display continuously by assigning either display to max/min through the *Display* menu.

CAUTION

- Changing the programming of the F1-F3 function keys will disable the default batch operation of these keys, and is not recommended for batch control applications.

Any of the digital inputs can be programmed to reset the max & min readings.

To display max/min readings continuously:

Assign either display to Max (dHi), Min (dLo), or toggle between Max and Min (dHL) every 10 seconds.

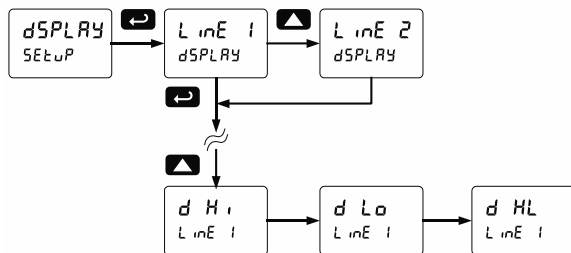

CAUTION

- Note that changing the default programming of the main or second displays may affect viewing the batch total (main display) or preset (second display) of the batch process.

Rounding Feature (round)

The rounding feature is used to give the user a steadier display with fluctuating signals. Rounding is used in addition to the filter function.

Rounding causes the display to round to the nearest value according to the rounding selected.

Modbus RTU Serial Communications (SERIAL)

The controller is equipped with serial communications capability as a standard feature using Modbus RTU Serial Communication Protocol.

The controller may be connected to a PC for initial configuration via the on-board USB connection. For ongoing digital communications with a computer or other data terminal equipment, use the RS-485 connection with the appropriate serial converter; see *Ordering Information* on page 7 for details.

CAUTION

- **DO NOT** connect any equipment to the RJ45 M-LINK connector. Otherwise damage will occur to the equipment and the controller.
- **DO NOT** disconnect the RJ45 connector located to the left of the power terminal block. Doing so will disable the on-board digital I/O, and the RS-485 serial communications.

Notes:

1. More detailed instructions are provided with each optional serial communications adapter.
2. Refer to the ProtEX-MAX Modbus Register Tables located at www.prediq.com for details.

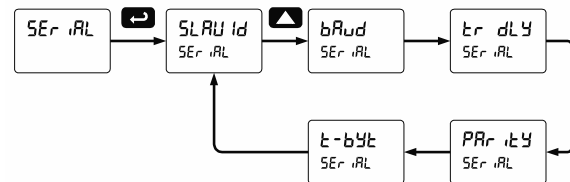

When using more than one controller in a multi-drop mode, each controller must be provided with its own unique address. The controller address (Slave ID) may be programmed between 1 and 247. The transmit delay may be set between 0 and 199 ms. The parity can be set to even, odd, or none with 1 or 2 stop bits.

Select Menu (SELEct)

The *Select* menu is used to select the signal conditioner applied to the input (linear), low-flow cutoff, and analog output programming. The multi-point linearization is part of the linear function selection.

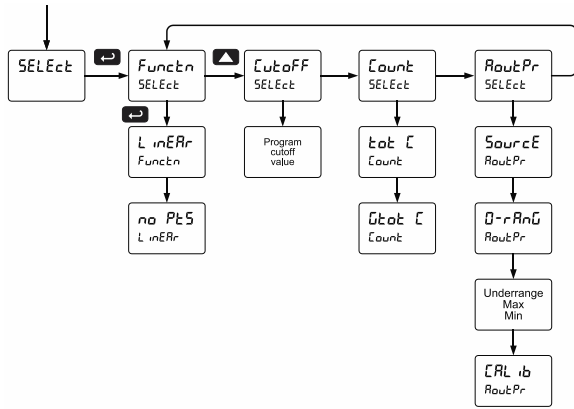

Input Signal Conditioning (Functn)

The *Function* menu is used to select the input signal conditioner applied to the input: linear. The multi-point linearization is part of the linear function selection.

Controllers are set up at the factory for linear function with 2-point linearization. The linear function provides a display that is linear with respect to the input signal.

Multi-Point Linearization (LinERr)

Controllers are set up at the factory for linear function with 2-point linearization. Up to 32 linearization points can be selected under the linear function. The multi-point linearization can be used to linearize the display for non-linear signals.

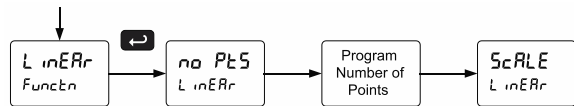

Low-Flow Cutoff (CutoFF)

The low-flow cutoff feature allows the controller to be programmed so that it always displays zero at very low flow rates.

The cutoff value may be programmed from 0.1 to 999999. The controller will display zero below the cutoff value. Programming the cutoff value to zero disables the cutoff feature.

Total and Grand Total Count Direction (Count)

By default, the batch total and grand total count up during batch processes. *Count* parameter allows this to change. When set to count down, the batch total will count down from the preset to 0. When set to count down, the grand total will count down from a starting value to zero.

Analog Output Programming (RoutPr)

The *Analog Output Programming* menu is used to program the behavior of the 4-20 mA output. The following parameters and functions are programmed in this menu:

1. Source: Source for generating the 4-20 mA output (e.g. Rate)
2. Overage: Analog output value with display in overrange condition
3. Underrange: Analog output value with display in underrange condition
4. Max: Maximum analog output value allowed regardless of input
5. Min: Minimum analog output value allowed regardless of input
6. Calibrate: Calibrate the internal 4-20 mA source reference used to scale the 4-20 mA output

Analog Output Source

The source for generating the 4-20 mA output may be assigned to the rate/process variable, total, grand total, maximum or minimum value reached by the rate/process, one of the set points, or the Modbus PV input.

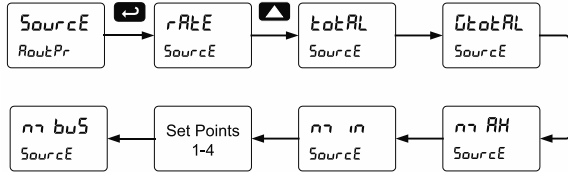

Analog Output Calibration

To perform the analog output calibration, it's recommended to use a milliamp meter with a resolution of at least 0.1 μ A to measure the output current. The values saved internally during this procedure are used for scaling the 4-20 mA output in the *Setup* menu.

Analog Output Calibration Procedure

1. Wire the PD8-6310-WM 4-20 mA output to a current loop that includes a power supply (internal or external 12 to 24 VDC), and the mA input on the digital meter. See *Figure 27. 4-20 mA Output Connections* on page 31 for details.
2. Turn on all devices. Allow for a 15 to 30 minute warm-up.
3. Go to the Advanced Features menu, navigate to Select (5E1 Ect) and choose Analog Output Programming (Rout Pr) → Calibration (Erl bi) menu and press **Enter**.
4. The display will show 4 mA. The PD8-6310-WM mA output should now be close to 4 mA. Press **Enter** and the display will show 04.000. Enter the actual value read by the digital mA meter and press **Enter**.
5. The display will show 20 mA. The PD8-6310-WM mA output should now be close to 20 mA. Press **Enter** and the display will show 20.000. Enter the actual value read by the digital mA meter and press **Enter**.
6. The meter will now calculate the calibration factors and store them.
7. Press **Menu** to exit and return to Run mode.

Programmable Function Keys User Menu (ህይድ)

⚠ CAUTION

- Changing the programming of the F1-F3 function keys will disable the default batch operation of these keys, and is not recommended for batch control applications.

The *User* menu allows the user to assign the front panel function keys F1, F2, and F3, the digital input F4 (located on the input signal connector), and four digital inputs (located on the digital I/O connector) to access most of the menus or to activate certain functions immediately (e.g. reset max & min, hold relay states, etc.). This allows the controller to be greatly customized for use in specialized applications.

The four digital outputs can be assigned to a number of actions and functions executed by the controller (i.e. alarms, relay acknowledgement, reset max, min, or max & min, tare, and reset tare). The digital outputs can be used to trigger external alarms or lights to indicate these specific events.

Function Keys & Digital I/O Available Settings

Refer to the following table for descriptions of each available function key or digital I/O setting.

Display	Description
ኛጸገቲ	Starts the batch process
ኛቲዐP	Stops the batch process
ኛገቲኛቲP	Allows the same function key to both start and stop the batch process
ገረሃ ፈ	Disable all relays until a button assigned to <i>enable relays</i> (ገረሃ ፎ) is pressed
ገረሃ ፎ	Enable all relays to function as they have been programmed
ቫ ዘዐረፈ	Hold current relay states and analog output as they are until a button assigned to <i>enable relays</i> (ገረሃ ፎ) is pressed
ፈ ዘዐረፈ	Hold the current display value, relay states, and analog output momentarily while the function key or digital input is active. The process value will continue to be calculated in the background.
ረገገ ገገ	Display maximum display value on line 1
ረገገ ረዐ	Display minimum display value on line 1
ረገገ ዘረ	Display maximum & minimum display values on line 1
ረገገ፯ ገገ	Display maximum display value on line 2
ረገገ፯ ረዐ	Display minimum display value on line 2
ረገገ፯ ዘረ	Display maximum & minimum display values on line 2
ረገገ፯ ርቲ	Display the grand total on line 2
ረገገ፯ ርር	Display the batch count on line 2

Display	Description
ረገገገገ	Directly access the manual control menu
ፈ ገገገገ	Disable the selected function key or digital I/O
ገርዘ	Acknowledge all active relays that are in a manual operation mode such as auto-manual or latching
ገፎፎፎፎ	Directly access the reset menu
ገፎፎ ፎ	Reset the total
ገፎፎ ርቲ	Reset the grand total
ገፎፎ ርር	Reset the batch count
ገፎፎ ዘገ	Reset the maximum display value
ገፎፎ ረዐ	Reset the minimum display value
ገፎፎ ዘረ	Reset the maximum & minimum display values
ገፎፎገገ	Directly access the relay menu
ገፎፎፎፎፎ	Change the preset value
ፎፎፎ ፯*	Directly access the set point menu for relay 2 (*through 8)
ገገገገገ	Mimic the menu button functionality (digital inputs only)
ገ ገገገገ	Mimic the right arrow/F1 button functionality (digital inputs only)
ሀP	Mimic the up arrow/F2 button functionality (digital inputs only)
ፎገገገገ	Mimic the enter/F3 button functionality (digital inputs only)
F ገገ ገ*	Force relay 1 (*through 4) into the on state. This function is used in conjunction with a digital input to achieve interlock functionality. See <i>Setting Up the Interlock Relay (Force On) Feature</i> on page 50 for details about interlock relays.
ገገገ ገ*	Provide indication when alarm 1 (*through 4) has been triggered (digital outputs only)

Troubleshooting

Due to the many features and functions of the controller, it's possible that the setup of the controller does not agree with what an operator expects to see. If the controller is not working as expected, refer to the *Diagnostics* menu and recommendations below.

Diagnostics Menu (d iRG)

The *Diagnostics* menu is located in the *Advanced Features Menu*; to access the *Diagnostics* menu refer to page 59.

This menu allows the user to test the functionality of all the controller LEDs, check the controller's software and version information, and erase the MeterView Pro software installation files from the controller. Press the Enter button to view the settings and the Menu button to exit at any time.

For a description of the diagnostic messages, see *Advanced Features Menu & Display Messages*, page 59.

Testing the Display LEDs

To test all LEDs on the display:

1. Go to the *Diagnostics* menu (d iRG) and press Enter button.
2. Press Up arrow button and scroll to *LED Test* menu (LEd t).
3. Press the Enter button to activate the LED Test. The controller will cycle through all digits, decimal points, and relay indicators to enable the operator to check that all LEDs are functioning properly.
4. Press the Enter button again to access the *Information* menu (i nF a) or press the Menu button to return to Run Mode.

Determining Software Version

To determine the software version of a controller:

1. Go to the *Diagnostics* menu (d iRG) and press Enter button.
2. Press Up arrow button and scroll to *Information* menu (i nF a).
3. Press Enter to access the software number (SFt) and version (VER) information. Write down the information as it is displayed. Continue pressing Enter until all the information is displayed.
4. The controller returns to Run Mode after displaying all the settings.

Reset Controller to Factory Defaults

When the parameters have been changed in a way that is difficult to determine what's happening, it might be better to start the setup process from the factory defaults.

Instructions to load factory defaults:

1. Enter the *Advanced Features* menu. See *Advanced Setup & Programming*, page 59.
2. Press Up arrow to go to *Diagnostics* (d iRG) menu.
3. Press and hold Right arrow for three seconds, press Enter when display flashes rESEt.
Note: If Enter is not pressed within three seconds, the display returns to the *Diagnostics* menu.
4. The controller goes through an initialization sequence (similar as on power-up) and loads the factory default settings.

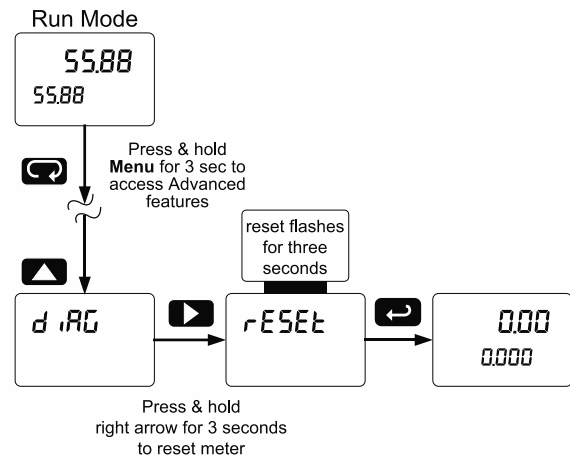

Factory Defaults & User Settings

The following table shows the factory setting for the major programmable parameters on the controller.

Factory Defaults & User Settings		
Parameter	Display	Default Setting
Input type	Input	Pulse
Total	YES	Total enabled
Units	units	Rate / total / G total Pulse / Pulse / Pulse
Rate decimal point	dddddd	1 Place
Total decimal point	dddddd	1 Place
Grand Total decimal point	dddddd	0 Places
K-Factor	Factor	1.000
Function	Function	Linear
Number of points	no. Pts	2
Programming	Prog	Scale
Input 1	inp 1	00000.0
Display 1	dis 1	00000.0
Input 2	inp 2	10000.0
Display 2	dis 2	10000.0
Display line 1	line 1	Display batch total
Display line 2	line 2	Display preset
Display intensity	dis intensity	6
Total time base	time base	Second
Total conversion factor	conversion factor	1.000
Batch mode	mode	Manual
Grand total time base	time base	Second
Grand total conversion factor	conversion factor	1.000
Grand total reset	reset	Manual
Relay 1 assignment	rel 1	Total
Relay 2 assignment	rel 2	Total
Relay 2 pre-close	pre-close	No
Relay 3 assignment	rel 3	Rate
Relay 4 assignment	rel 4	Rate
Relay 1 action	rel 1	Automatic
Batch preset	batch preset	100.0
Relay 2 action	rel 2	Automatic
Relay 2 set point	rel 2	200.0
Relay 3 action	rel 3	Automatic
Relay 3 set point	rel 3	3.000
Relay 3 reset point	rel 3	2.500
Relay 4 action	rel 4	Automatic
Relay 4 set point	rel 4	4.000
Relay 4 reset point	rel 4	3.500
Fail-safe relay 1	FLS 1	Off
Fail-safe relay 2	FLS 2	Off

Factory Defaults & User Settings

Parameter	Display	Default Setting
Fail-safe relay 3	FLS 3	Off
Fail-safe relay 4	FLS 4	Off
On delay relay 1	on 1	0.0 sec
Off delay relay 1	off 1	0.0 sec
On delay relay 2	on 2	0.0 sec
Off delay relay 2	off 2	0.0 sec
On delay relay 3	on 3	0.0 sec
Off delay relay 3	off 3	0.0 sec
On delay relay 4	on 4	0.0 sec
Off delay relay 4	off 4	0.0 sec
Display 1 analog out	dis 1	0
Output 1 value	out 1	4.000 mA
Display 2 analog out	dis 2	1000.0
Output 2 value	out 2	20.000 mA
Source analog output	source	Rate/process
Overrange output	overrange	21.000 mA
Underrange output	underrange	3.000 mA
Loop break output	loop break	1.000 mA
Filter	filter	Hi Speed
Cutoff value	cutoff	0.0 (disabled)
Maximum output	max	23.000 mA
Minimum output	min	1.000 mA
Slave ID (Address)	slave id	247
Baud rate	baud	9600
Transmit delay	transmit delay	50 ms
Parity	parity	Even
Byte-to-byte timeout	byte-to-byte	010 (0.1 sec)
F1 function key	F1	Start
F2 function key	F2	Preset
F3 function key	F3	Stop
F4 function	F4	Start/Stop
Digital input 1	di 1	Menu
Digital input 2	di 2	Right arrow
Digital input 3	di 3	Up arrow
Digital input 4	di 4	Enter
Digital output 1-4	do 1	Alarm 1-4
Password 1	pass 1	000000 (unlocked)
Password 2	pass 2	000000 (unlocked)
Password 3	pass 3	000000 (unlocked)
Total password	total pass	000000 (unlocked)
Grand total password	grand total pass	000000 (unlocked)

Troubleshooting Tips

This controller is a highly sophisticated instrument with an extensive list of features and capabilities. If the programming buttons are used to program the controller, it may be a difficult task to keep everything straight. That is why we strongly recommend the use of the free [MeterView Pro](#) software for all programming activities. The most recent version of the software is loaded at the factory in the internal controller's memory. A USB cable is provided for programming the controller using MeterView Pro software.

If you have programmed the controller with the programming buttons and it is not working as intended, try re-programming the controller using MeterView Pro software.

Symptom	Check/Action
No display at all	Check power at power connector
Not able to change setup or programming, L o c k is displayed	Controller is password-protected, enter correct six-digit password to unlock or Master Password of 508655.
Controller does not respond to input change	Check: <ol style="list-style-type: none"> 1. The input signal type and make sure it corresponds with the position of the input switch. 2. The input signal voltage level 3. If a <i>Low-Flow Cutoff</i> has been programmed, the controller will display zero below that point, regardless of the input.
Controller displays error message during calibration (E r r o r)	Check: <ol style="list-style-type: none"> 1. Signal connections 2. Input switch position 3. Minimum input span requirements
Controller displays <div style="text-align: center;"> 999999 -99999 </div>	Check: <ol style="list-style-type: none"> 1. The input signal frequency 2. K-Factor value or scaling, time base, and decimal point
Display is unstable	Check: <ol style="list-style-type: none"> 1. Input signal stability and value 2. Display scaling vs. input signal 3. Increase the gate settings to average more pulses
Display reading is not accurate	Check: <ol style="list-style-type: none"> 1. K-Factor value provided by the flowmeter manufacturer 2. Time base selected 3. Scaling or calibration
Display response is too slow	Check: Filter and gate values
Display does not respond to input changes, reading a fixed number	Check: Display assignment, it might be displaying max, min, or set point.
Display alternates between 1. H i and a number 2. L o and a number	Press Menu to exit max/min display readings.
Relay operation is reversed	Check: <ol style="list-style-type: none"> 1. Fail-safe in Setup menu 2. Wiring of relay contacts
Relay and status LED do not respond to signal	Check: <ol style="list-style-type: none"> 1. Relay action in <i>Setup</i> menu 2. Set and reset points
Flashing relay status LEDs	Relays in manual control mode or relay interlock switches opened.
Controller not communicating with application programs	Check: <ol style="list-style-type: none"> 1. M-Link Connector installed between PROVu electronics and ProtEX-MAX connector board. See <i>Figure 9: Integrated PROVu Required Connections</i> on page 25 2. Serial settings 3. Controller address and baud rate
If the display locks up or the controller does not respond at all	Cycle the power to reboot the microprocessor.

Troubleshooting Tips

Symptom	Check/Action
Cannot access main menu	You cannot access the main menu when a batch is running. Make sure the batch has stopped before trying to access the main menu.
Batch is continuously overfilling	A multi-stage batch with a pre-close amount may be necessary. See <i>Two-Stage Batch Control Setup Using Relays 1 & 2</i> on page 54.
Batch is not stopping when preset is reached	Check wiring. Relay 1 corresponds to the preset value.
SafeTouch buttons do not respond	<ol style="list-style-type: none"> 1. If mechanical button was pushed, the SafeTouch buttons will be re-enabled automatically 60 seconds after the last button push. 2. If slide switch on connector board is in DISABLE position, switch to ENABLE. 3. Strong direct sunlight may interfere with SafeTouch button operation. It is recommended to operate the buttons by standing so as to block direct sunlight.
Serial Communications METER LINK LED Indicator is off	Check: <ol style="list-style-type: none"> 1. Modular cable connection 2. Power to the device
If only the TX (or DATA IN) data status LED is flashing when serial communications attempted	Check: <ol style="list-style-type: none"> 1. Serial cable 2. Instrument address & baud rate 3. Program address & baud rate
If both data status LEDs (TX and RX) are off when trying to communicate	Remove all unnecessary cables and instruments from the bus. Try getting the system to work with only one device (to ease troubleshooting) and then expand the system one device at a time.
Communications slow	Increase the baud rate
Random communication errors	<ol style="list-style-type: none"> 1. Increase the TX delay time 2. Decrease the baud rate
Other symptoms not described above	Call Technical Support for assistance

Note: Certain sequences of events can cause unexpected results. To solve these issues, it is best to start fresh from factory defaults and use the manual as a step by step programming guide, rather than a random approach to programming. To reset the controller to factory defaults, see *Reset Controller to Factory Defaults* on page 65. In addition, for best results, we recommend using the free MeterView Pro software for all programming needs.

Complete Product Line of Displays and Controllers IN ALL SHAPES, SIZES & LOCATIONS



Big, Bright Displays
For Indoor or Outdoor
in Bright Sunlight



Large Dual-Line
6-Digit Display



24 VDC
Transmitter
Power Supply



MeterView® Pro USB
Programming Software



Universal 85-265
VAC or 12-24 VDC
Input Power
Options



4-20 mA, 0-10 V,
Thermocouple, RTD,
Strain Gauge, High
Voltage, & Modbus Inputs



Up To Four
3 A Form C
Relays (SPDT)



FM APPROVED SP Ex CE IECEX

UL

CE UL

EXPLOSION-PROOF ProtEX-MAX Series

- NEMA 4X, IP68 Rated Enclosure
- SafeTouch® Through-Glass Buttons
- Operating Temperature of -40 to 65°C
- Worldwide Approvals

LARGE DISPLAYS Helios Series

- 1.8" Digits Readable From 100 Feet
- NEMA 4X, IP65 Rated Enclosure
- Operating Temperature of -40 to 65°C
- Now UL and C-UL Approved!

PANEL METERS ProVu Series

- NEMA 4X, IP65 Rated Front
- Programmable Function Keys
- UL, C-UL, and CE Approvals
- 1/8 DIN Size

Go to PREDIG.COM for details on ProVu, ProtEX-MAX and Helios Series Meters

Contact Precision Digital

Technical Support

Call: (800) 610-5239 or (508) 655-7300

Fax: (508) 655-8990

Email: support@predig.com

Sales Support

Call: (800) 343-1001 or (508) 655-7300

Fax: (508) 655-8990

Email: sales@predig.com

Place Orders

Email: orders@predig.com

For the latest version of this manual please visit

www.predig.com

PRECISION DIGITAL CORPORATION

233 South Street • Hopkinton MA 01748 USA

Tel (800) 343-1001 • Fax (508) 655-8990

www.predig.com

